

High Efficiency Water and Waste Water Treatment



Integrated Solutions



Pall SCHUMACHER Offers Intelligent Solutions for Water and Waste Water Treatment

As the value and therefore the cost of water increases, and as environmental regulations for wastewater discharge become more stringent, more and more municipal and industrial customers decide to treat their waste water as efficiently and as economical as possible.

To meet these strict requirements, Pall Schumacher utilises many decades of extensive application know how, and an enormous reference based range of experience to offer the following HIGHLIGHTS:

Continuous use of BRANDOL®:

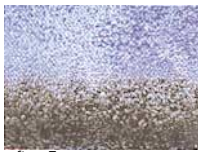

after 5 years



after 10 years

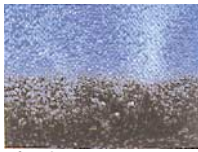

after 25 years

- Fine Bubble Aeration for Biological Sewage Treatment: Brandol®
- Well screens for Potable Water and Soil Remediation: SCHUMASOIL®
- Micro- and Ultra-Filtration with High Performance Ceramic Membranes
- Fine Porous Support Structures for Microorganisms in Bioreactors
- Continuous Removal of Oil and Fat from Liquid Surfaces
- High Porous Ceramic Elements for Treatment of Drinking Water and Liquids

- page 2
- page 5
- page 6
- page 6
- page 7
- page 8

Fine Bubble Aeration for Biological Sewage Treatment

Experience Based Philosophy.

Pall Schumacher has a well defined mission: To use its many years of experience and know how to realize integrated and optimised solutions to the benefit of its customers and the environment. As a result of many decades in the field of biological sewage treatment plants, Pall Schumacher is best positioned to create the optimum solution and to deal with the widest variety of applications.

specialised porous media used for aeration since delivery of the first diffuser elements in 1918. Over many decades Pall Schumacher has developed an optimised cylindrical diffuser - in close operation with Universities and Institutes to fulfill all demands for advanced biological waste water treatment for today - and tomorrow. For generating the optimum ambient conditions for biological action, and to ensure a constant and safe operation, Pall Schumacher offers an excellently uniform distribution of fine air bubbles using cylindrical diffusers in flat bottom aeration technique in continuously operated sewage treatment tanks.

Based on the operating results from more than 1,000 reference plants, Pall Schumacher has fine tuned and optimised diffuser geometry to offer a proven design, guaranteed to give successful operation for nitrification, denitrification and organic destruction (including BOD/COD reduction).

Pall Schumacher has manufactured spe-

Optimized pore size distribution offers flexible air flux ratios.

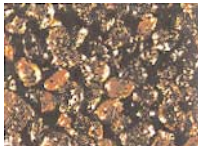

Texture of BRANDOL® 60





The Genuine Sewage Aeration Large And Compact Installations

Pall Schumacher has a very wide range of experience, both in the supply of large centralised municipal sewage treatment plant, eg. the installation of 35,000 m

BRANDOL® - diffusers in a large centralised municipal plant as well as the installation of a number of smaller 100 m in decentralised plants.

Examples for large installations of Municipal Sewage Treatment Plants, selected 3 from the reference list with more than 1,000 successfully running plants:

- D - Berlin Ruhleben 35.000 m BRANDOL® diffusers
- PL - Warschau Czajka 26.000 m BRANDOL® diffusers
- D - München Marienhof 20.000 m BRANDOL® diffusers

Longlife Rigid Ceramic Diffusers

Customers having chosen BRANDOL® for their sewage aeration, made the decision based on its excellent functionality, as well as the very rigid and wear resistant nature of the porous ceramic diffusers: Enduring, continuous and efficient operation are the significant features, ensuring long-evity in service. Our customers often enjoy >20 years of efficient and trouble free operation using our BRANDOL® diffusers.

This proven service history means minimum spare parts investment and a vast-

ly reduced need for changing the diffusers over the years.

The BRANDOL® ceramic consists of a porous material composed of naturally spherical quartz particles bonded with a synthetic resin. This porous medium has a smooth inner pore structure and because of the chemical properties of the resin, exhibits a natural bacteriostatic activity [against the growth of algae by activated sludge]. The smooth round structure also helps to reduce clogging, giving low pressure drops and minimised operating-costs.

A very effective cleaning of the diffusers can be carried out by high pressure cleaning if required.

The Process:



Anaerobe zone (Denitrification)

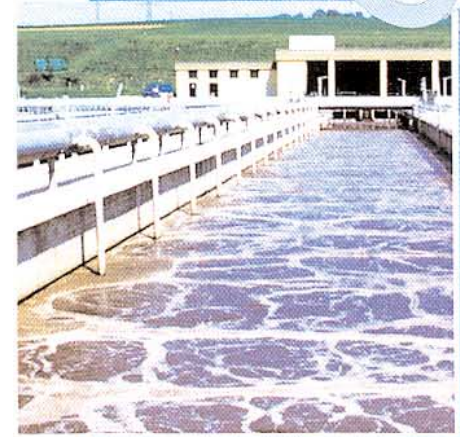

Aerobe zone (Nitrification)

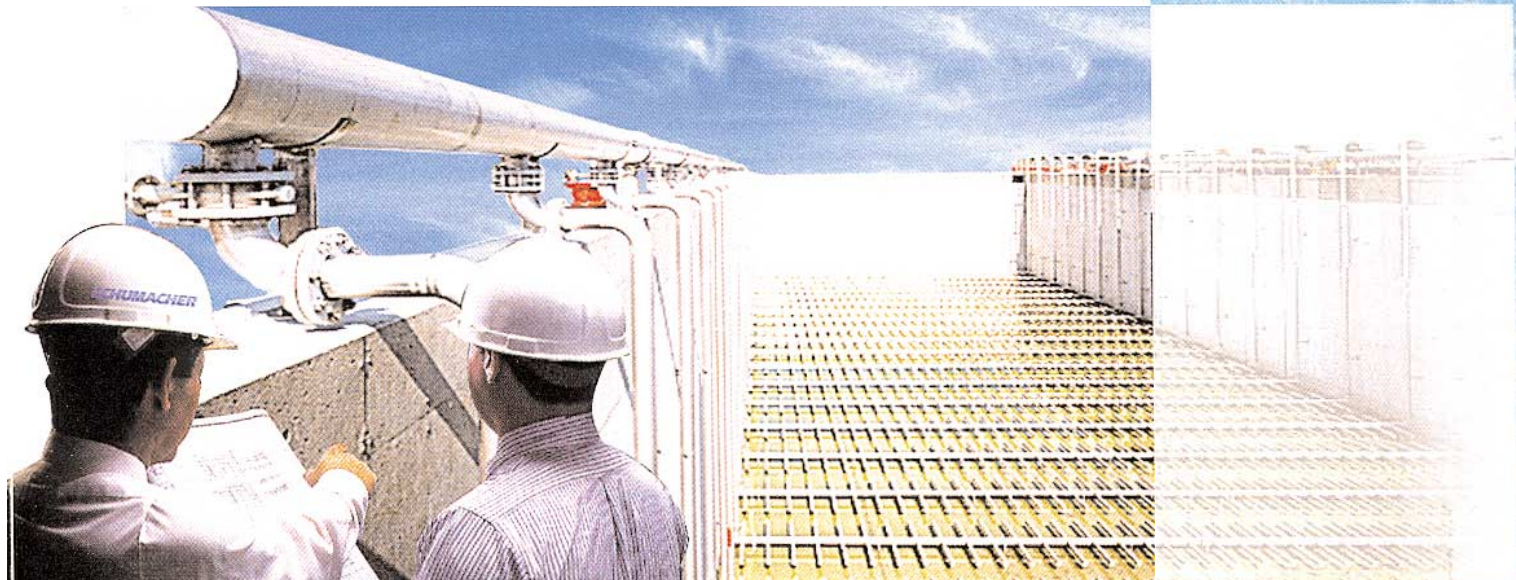



The Original: BRANDOL®

Repeating natural procedures continuously.

The self-cleaning of water, effected by micro-organisms, is a permanent procedure always running in free nature. In each mountain brook, the water becomes richer in oxygen continuously by its flow, and thus cleans itself.

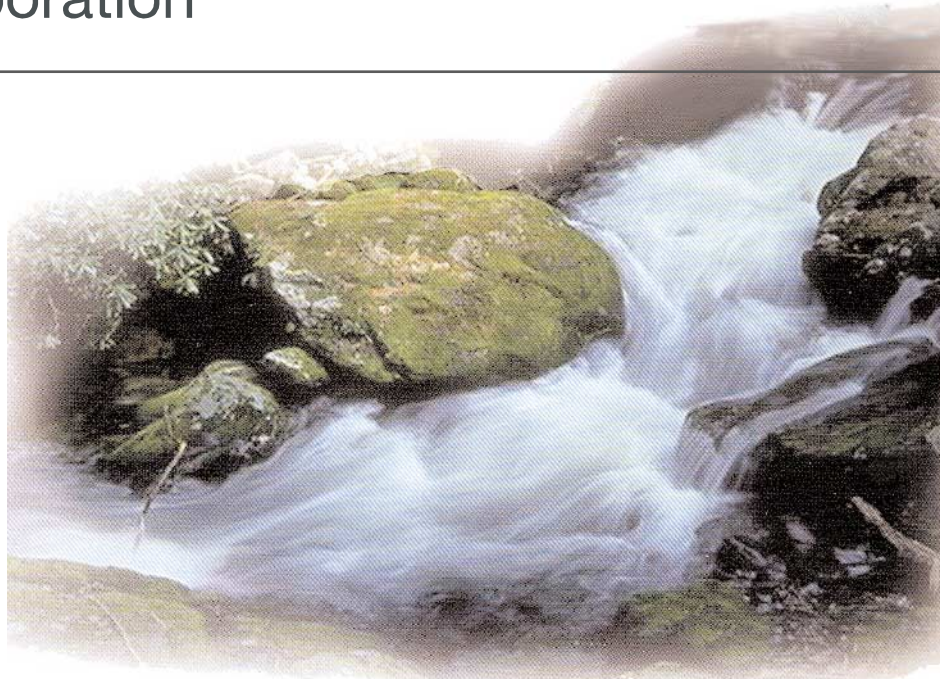

The only additive: Clean Air

Waste water contains a range of chemicals, organic substances and nitrogen compounds. The objective of the treatment is to remove these and to discharge the clarified water back into the natural waters or to reuse it after additional UF/RO-treatment. Flat bottom aeration with BRANDOL®

runs continuously without interruption. Ordinary air is injected into the diffuser elements which are installed at a distance of approx. 20 cm from the bottom of the waste water tank generating enough turbulence to avoid sludge deposition.

Superior Oxygen Capacity.

Rigid porous ceramic diffusers of type BRANDOL® have a defined pore size to ensure specified oxygen flow through the waste water at a low pressure drop. The porous texture of BRANDOL® generates millions of fine bubbles enabling high mass transfer rates of the oxygen into the waste water (= oxygen capacity = OC). The individually fixed homo-

geneously distributed diffusers not only achieve locally high specific transfer rates, but also act as mini-mixers which homogenise the waste water and establish high turbulent flow and local vortexation achieving an excellent cleaning effect by establishing an optimum environment for microorganisms.

Advantages in Combination.

Combined installation of BRANDOL® diffusers (in zones with constant aeration) and SCHUMAFLEX-RK membrane diffusers (in intermittent aerated zones) ensures an economical and flexible system allowing a variation in operation of the plant and subsequent lower specific costs.

BRANDOL's Favourable Advantages:

- low investment costs
- minimum operating and service costs
- excellent oxygen capacity (OC)
- long lifetime (> 20 years)
- better oxygen efficiency (OE)
- with increasing operation time
- easy cleaning of diffusers
- low pressure drop

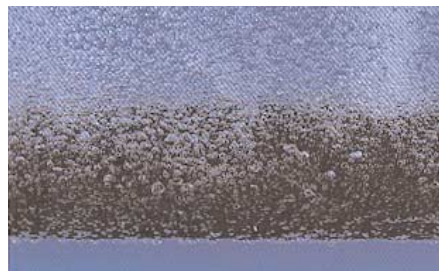

Bubbles of optimum size and in large quantity are necessary for optimised economic aeration

BRANDOL's® Technical Data:

| | |
|-------------------|---------------------|
| Material | Quarz, resin bonded |
| Mean pore size | [µm] 70 |
| Temp. resistance | [°C] up to 130 |
| Aeration surface | [m²/m] 0.22 |
| Length | [mm] 500 and 750 |
| Dia (outer/inner) | [mm] 70/40 |



Municipal Sewage Treatment Plant
Warsaw (PL): 25,900 m BRANDOL®



Industrial Sewage Treatment Plant
Bayern (D): 1,620m BRANDOL®



Municipal Sewage Treatment Plant
(NL): 4,500 m BRANDOL®



Well Screens for Potable Water and Soil Remediation

The Innovative Concept

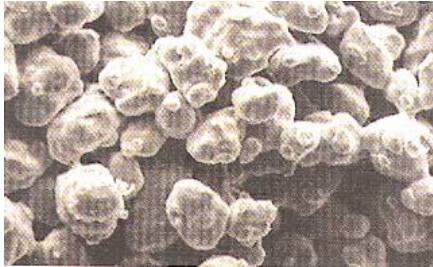

SCHUMASOIL® is a porous High Molecular Weight Polyethylene well screen designed to minimise flow resistance. This is achieved by providing an optimised porosity up to 45 % which is uniformly distributed along the well screen's entire length. Maximised porosity, uniform pore distribution and a tightly controlled pore size, provide the user with the ability to

match flow characteristics of the well screen to that of the formation.

Conventional slotted well screen has (at best), an open surface area of between 5-15%, and is only effective in coarse grained soils. Generally, slotted pipe exhibits undesirable high entrance and exit velocities, which can result in preferential flow and even cause fracturing within the formation. Premature clogging and breakthrough is also a well known and undesirable feature of using simple slotted pipe e.g. in fine and sandy soils.

SCHUMASOIL® well screen exhibits an open surface area of 25 - 36 % .In addition to use in conventional vertical water recovery wells, SCHUMASOIL® is an excellent product for use in horizontal wells. The porosity of the material provides all the advantages of a filter pack, but is much easier to install due to its light weight and flexibility. Today, several hundred wells in service are equipped with SCHUMASOIL® well screen.

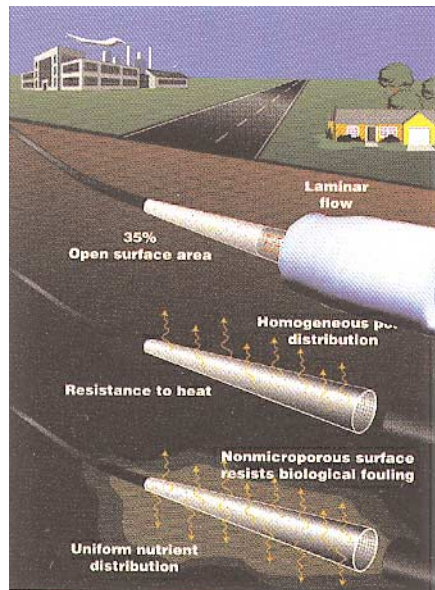

When high compressive strength is required, SCHUMASOIL® is

available as Type VBW which has a built in reinforcement. This reinforcement increases the well screen's resistance to collapse, making it an ideal product to use in horizontal well installations.

Features and Benefits:

- Highly porous with a homogeneous and uniform pore structure
- High permeability for water, soil vapour and solvent phases
- High level of chemical resistance including TCE, BTEX
- Low sorbability
- Light weight
- High radius of curvature
- Inert material
- Low long term well operating costs
- Four different pore sizes offered to match soil formation characteristics
- Environmentally friendly

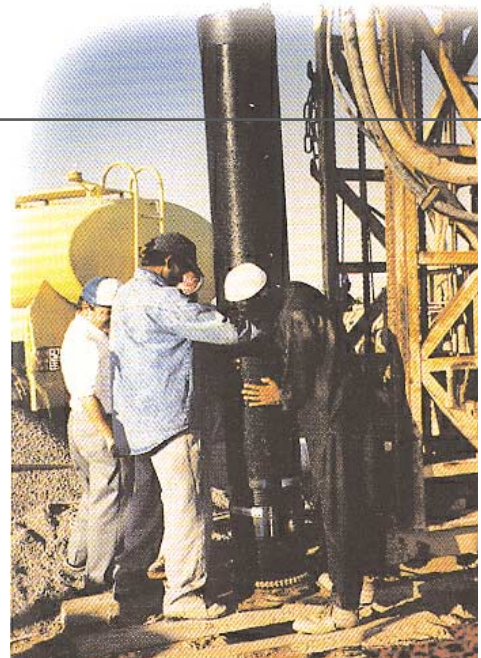

Applications:

- Soil vapour extraction
- Sparging
- Bioremediation
- Free product recovery
- Ground water extraction
- Degassing
- Drainage
- Seepage pipes
- Combination wells
- Passive attenuation
- Water resource wells

Manufacture

The porous polyethylene well material is manufactured in Crailsheim only. Technical support for the application of polyethylene well screens can be given.

Patents and Trademarks

SCHUMASOIL® is registered trade mark of Pall Schumacher GmbH in Crailsheim.

Micro- and Ultra-Filtration with High Performance Ceramic Membranes



Introduction:

The SCHUMASIV product range covers pore sizes from 0.005 μm to 1.2 μm meeting the demands of a wide range of applications. SCHUMASIV ceramic membranes offer unique advantages compared to conventional polymer membranes e.g.

- High flux
- Excellent mechanical-strength
- Long life time
- Strong backflushing capability

Applications and Experience:

SCHUMASIV® is an ideal oil/water separation medium, and is successfully used in the treatment of waste water, e.g. for deoiling waste water or compressor condensate, cleaning of washing water from metal or textile cleaning, pre-treatment of landfill seepage and bilgewa-

ter treatment. The benefits of ceramic membranes are also employed in recycling technology, eg. for degreasing cleaning baths, paint, coating and enamel recycling or recycling of petrochemicals.

Further Features and Benefits:

- High temperature resistance, and high resistance to temperature changes
- High resistance against aggressive chemicals such as strong acids, alkalines and organic solvents
- Good wear resistance for excellent durability when filtering highly abrasive suspensions
- Hydrophilic surface
- High permeate flow

Fine Porous Support Structures for Microorganisms in Bioreactors

Highly Porous Granular Ceramic Material for Biotechnical and Catalytical Application

STUTTARTER MASSE is a microporous ceramic product formed of crushed grains, available from 0,4 to 12 mm.

SCHUMAPOR B is a highly porous, siliceous ceramic product in form of spheres or so called pellets, in sizes of 3 to 16 mm. Due to a flexible manufacturing process SCHUMAPOR B is also available in tailor-made material composition for extraordinary customer applications.

Applications:

Both materials are distinguished by high temperature and abrasive resistance. They show a high porosity as well as a high specific surface which offers immobilisation of microorganisms. A moistening of hydrophil bulk products with e.g. catalytic fluids shows best results.

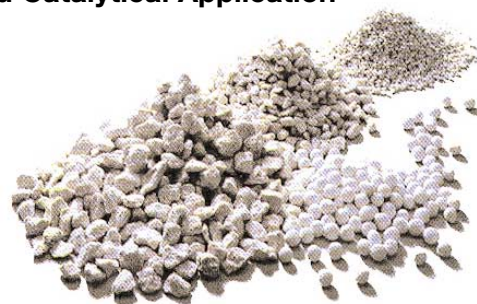

STUTTARTER MASSE (SM)

SCHUMAPOR B (SPB)

Applications:

Bulk material

Fill for gravel bed filters for filtration and adsorption, e.g. for purification of water.

Carrier Material

Carrier material for catalysts and indicators e.g. gas detector devices

Substrate

Substrate for the immobilisation of microorganisms in order to increase the biomass concentration e.g. biological purification of waste water and off-gases e.g. production of chemical substances like alcohol, acetic acid etc.

Continuous Removal of Oil and Fat from Liquid Surfaces

The Efficiency without Intermission:

The Pall Schumacher belt oil skimmer ensures an effective and economic separation of non-emulsified oils and liquid fats from liquid surfaces. The lower part of the vertically installed belt is completely

immersed in the liquid to be purified. Floating oil and fat adhere to the revolving belt and are thus skimmed off from the liquid surface. The oil and fat is wiped off close to the drive pulley above.

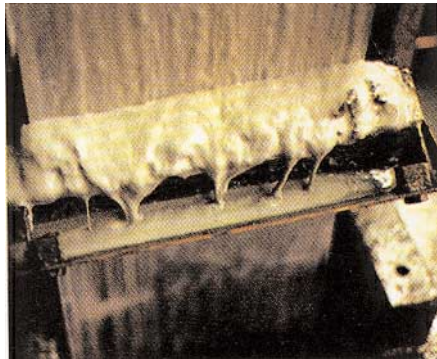

The belt speed is adjustable from 0 - 12 m/min (frequency changer + potentiometer).

Typical applications with proven references are:

- cooling water treatment, iron and steel industry
- washing water treatment, metal processing
- ground water treatment, soil remediation
- sewage treatment, food industry

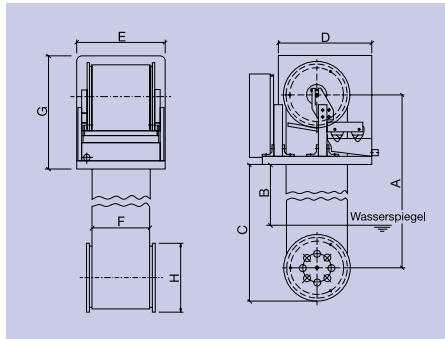

Capacity Data:

- Removal capacity for mineral oil: **max. 150 l/h (0.60 gpm)**
- Residual water content of separated oil down to **1 %**, depending on temperature, liquid and viscosity
- Belt length lift (depending on operating conditions): **up to 12.0 m**
- Belt speed: **0 - 12 m/min** (adjustable)
- Drive: **electrical gear motor** (drum motor), 3 x 220 V, 50 Hz, 0.12 kW, protection IP 54, isolation class F

Three sizes are available:



SOP 100-8
with a capacity of
100 l/h oil (SAE 30),
belt width 203 mm



SOP 50-4
with a capacity of 50
l/h oil (SAE 30), belt
width 102 mm

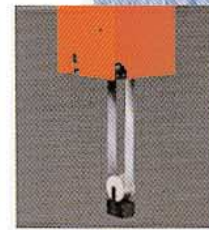

SOP 40-2
with a capacity of 40
l/h oil (SAE 30), belt
width 50 mm

Advantages of Belt Skimmers:

- low investment and operating costs,
- perfect operation even with varying water levels,
- residual water content of separated oil or fat down to 1%,
- compact design and minimum maintenance

NOVELTY in 2004

Turbo-Oilskimmer with pneumatic drive for ex range. Technical details on request.



Excellent Adsorption Results with Activated Carbon Blocks

SCHUMASORB® is a sintered activated carbon material formed into stable and mechanically strong cylinders, tiles or completely fitted cartridges.

Compared to wound or pleated filters, SCHUMASORB® ensures an extended service life.

SCHUMASORB® an ideal filter for a great variety of applications, e.g.:

- Decolouring of liquids
- Elimination of adsorbable compounds and contaminations from liquids
- Dechlorination of water



Best Results with Fireclay Ceramics for Potable Water Treatment and Aeration

SCHUMATHERM® is a high-quality porous fireclay material. This material is distinguished by its good chemical and thermal resistance. SCHUMATHERM® meets the requirements of the potable water regulations.

SCHUMATHERM® guarantees best results at following applications, e.g.:

- De-acidification (CO₂ stripping)
- Increase of O₂ concentration
- Deferrization and demanganization



Core Solutions in Filtration and Fluidization:

Media and hardware for fine filtration of liquids: brine (chlor-alkaline-electrolysis), acids, alkalines, solvents, electrolytes, beer, fruit, juice, catalyst recovery.

Media and hardware for filtration of gases: compressed air, natural gas, steam, chlorine gas, hot gases (exhaust and process gases up to 800°C.)

Pre-fabricated PE plates and tailor-made silo-cones, bottoms and other internals made for discharge, fluidisation and homogenization.

Ask for more Information about the Pall Schumacher Supply Range. We also offer Solutions for Filtration and Fluidization.