



Food and Beverage

FBT Series Filter Housings

3-ROUND FILTER HOUSING
for sanitary liquid filtration



FBT Series

3-ROUND FILTER HOUSING

Description

FBT Series sanitary housings are designed specifically for liquid filtration in the food and beverage industry.

- Enhanced cleanability and microbiological safety due to crevice-free, polished and hygienic design
- Corrosion resistance and durability with 316L stainless steel wetted parts and high-quality welds
- Cost-effective without sacrificing quality and performance

FBT Housings are available in a standard sanitary design allowing a variety of connection options, or in a 3-A sanitary design, which meets the requirements of 3-A Sanitary Standards #10-04.

Features and Benefits

- T-style multi-round housing
- Suitable for flow rates up to 227 liters/min (60 USgpm) depending upon cartridge type and size
- Suitable for CIP and SIP
- Beveled housing tubesheet and aseptic-style housing seal provides enhanced drainability and a crevice-free connection between the housing head and bowl
- Electropolished head and elbows and mirror polished bowl ensures optimal cleanability in critical areas while maintaining cost-effectiveness
- New cartridge locking design features additional cut-outs to traditional half-moon portions of the Code 7 bayonet locks, enhancing cleanability and drainability, (Figure 1)
- Operator-friendly V-Band housing closure simplifies handling
- Housings with clamp coupling and butt weld connection options meet the design requirements of 3-A Sanitary Standards #10-04
- Design satisfies EC Pressure Equipment Directive (PED) 97/23/EC, ATEX 94/9/EC Group II Category 2

FBT Series Filter Housings Technical Information

Specifications

Minimum / Maximum Operating Pressure ¹	-1 to 10 bar (-14.5 to 150 psig)
Minimum / Maximum Operating Temperature ^{2,5}	Fluorocarbon Elastomer and Silicone seals -10 to 150 °C (14 to 300 °F) EPR seals -10 to 121 °C (14 to 250 °F)
Steam Sterilization ^{2,5}	Fluorocarbon Elastomer and Silicone seals 3.7 bar / 150 °C max (53 psig / 300 °F) EPR seals 1 bar / 121 °C max (14.5 psig / 250 °F)
Materials of Construction	Wetted parts 316L stainless steel
Housing Seal Options ^{3,4}	Fluorocarbon Elastomer Silicone EPR
Surface Finish	≤ 0.8 micron Ra (≤ 32 Ra microinches)
Connections	DIN 11851 Clamp Coupling Butt Weld
Filter Cartridge Compatibility ⁵	Pall Code 2 or Code 7 single open-end
Design Specification	Design capability of 4 times maximum operating pressure. Each housing is hydrostatically tested to 1.6 times maximum

¹ Maximum operating pressure ratings are vessel ratings only. Safe operating temperature and pressure will depend on filter cartridge and seal used. For compatibility details, please contact Pall.

² For applications involving fluids below 0 °C (32 °F), please contact Pall.

³ Check local pressure vessel code requirements.

⁴ Seal materials meet FDA requirements for food contact use detailed in 21 CFR Section 177.2600 (excluding milk and edible oils). Additionally, seal materials in 3-A Series housings meet the requirements specified by 3-A Sanitary Standards #10-04.

⁵ Refer to Pall Food and Beverage filter cartridge literature for additional guidelines on use.



Figure 1

FBT Series Filter Housings

Technical Information

FBT03 and FBT03 3-A Series Housings

Nominal Dimensions in mm (inches) – for specific dimensions, please contact Pall

Code	Cartridge Height	A	B1 - FBT03	B2 - FBT03 (3-A)	C - Element Removal	D - DIN Connection	D - Clamp Connection	D - Butt Weld Connection
10	254 (10)	820.5 (32.2)	530 (20.9)	558 (22.0)	310 (12.2)	305 (12)	294 (11.6)	314 (12.4)
20	508 (20)	1070.5 (42.1)	780 (30.7)	808 (31.8)	560 (22.0)	305 (12)	294 (11.6)	314 (12.4)
30	762 (30)	1330.5 (52.4)	1040 (40.9)	1068 (42.0)	807.5 (31.8)	305 (12)	294 (11.6)	314 (12.4)
40	1016 (40)	1570.5 (61.8)	1280 (50.4)	1308 (51.5)	1057 (41.6)	305 (12)	294 (11.6)	314 (12.4)

Volume and Weight

Code	Volume L (US Gal)	Weight kg (lb)
10	8.2 (2.2)	19 (41.8)
20	14.2 (3.8)	21.2 (46.6)
30	20 (5.3)	23.5 (51.7)
40	26 (6.9)	25.7 (56.5)

Typical Water Flow / Pressure Drop Characteristics*

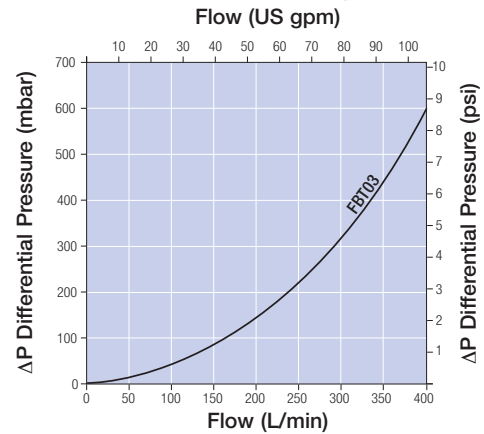

* The flow/pressure drop curve refers to the empty housing only, for water at 20 °C (68 °F). For other liquids, multiply housing pressure drop by the specific gravity of the fluid.

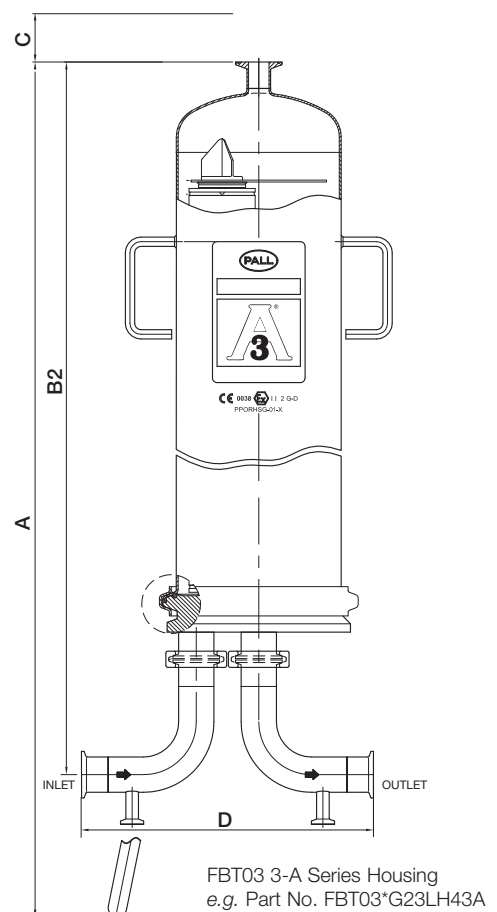
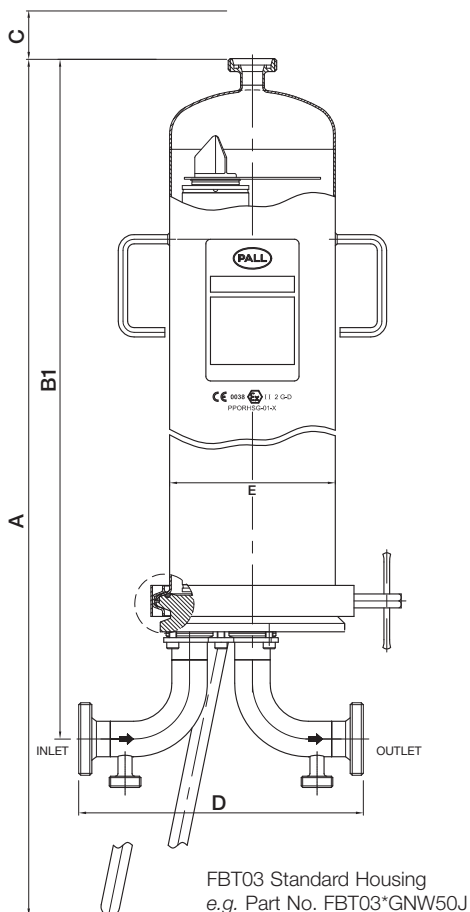

FBT Series

FBT Series Filter Housings Ordering Information

3-ROUND FILTER HOUSING

This is a guide to the part numbering structure and possible options only.
For availability of specific options, please contact Pall.

Part Number: **FBT 03** **G**

Table 1 Table 2 Table 3 Table 4

Example Part Number: **FBT 03 1 G 23L J 3A**

Note: See bold reference codes in the tables.

Table 1

Code	Cartridge Height
1	254 mm (10")
2	508 mm (20")
3	762 mm (30")
4	1016 mm (40")

Table 3

Code	Housing Seal Options
H	Fluorocarbon Elastomer
H4	Silicone
J	EPR

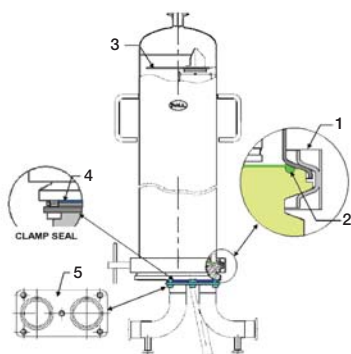

Spare Parts

Description	Quantity	Material	Part No.
Bowl seal ^[2]	1	H	CA67405
Bowl seal ^[2]	1	H4	CA67404
Bowl seal ^[2]	1	J	LS00275
1.5" Clamp seal ^[4]	2	H	LS00149
1.5" Clamp seal ^[4]	2	H4	LS00097
1.5" Clamp seal ^[4]	2	J	LS00098
Retaining plate ^[3]	1	316L s/s	ACS0926AA
Clamp plate and bolts (std) ^[5]	1	304 s/s	CC67519
Bowl clamp (std) ^[1]	1	304 s/s	ACS0925DM
Bowl clamp ^[1] (3-A Series)	1	304 s/s	ACS0928DM
1.5" V-clamp (3-A Series)	2	304 s/s	ACS0609DA

Table 2

Code	Inlet / Outlet	Vent	Drain
NW50 ⁶	NW50 DIN 11851	NW25 DIN 11851	NW15 DIN 11851
23L	1½" Clamp Coupling	1" Clamp Coupling	½" Clamp Coupling
34 ⁶	Butt Weld 50.8 x 1.6	Butt Weld 25.4 x 1.6	Butt Weld 12.7 x 1.6

⁶ For purposes of sizing, consider 37 mm (1½") actual tube diameter at housing head.

Table 4

Code	Housing Design
Blank	Standard
3A	3-A Series

Note: Housings with clamp coupling and butt weld connection options are available in both Standard and 3-A Series design. Housings with DIN connections are only available in Standard design.



Figure 2



Figure 3



Figure 4



Figure 5

Optional Accessories

Description	Connections	Seal Material	Part Number	Connections	Seal Material	Part Number
Vent Kit - Gauge (Figure 2)	NW25	H	ACS0949AM	1" Clamp Coupling	H	ACS0958AM
		H4	ACS0950AU		H4	ACS0959AU
		J	ACS0951AM		J	ACS0960AM
Vent Kit - Stäubli* Vent Valve (Figure 3)	NW25	H	ACS0952AM	1" Clamp Coupling	H	ACS0961AM
		H4	ACS0953AU		H4	ACS0962AU
		J	ACS0954AM		J	ACS0963AM
Vent Kit - Stäubli* Vent Tee (Figure 4)	NW25	H	ACS0946AM	1" Clamp Coupling	H	ACS0955AM
		H4	ACS0947AU		H4	ACS0956AU
		J	ACS0948AM		J	ACS0957AM
Drain Kit - Hosetail Valve (Figure 5, 2 required per housing)	NW15	H	ACS0929EM	½" Clamp Coupling	H	ACS0932AM
		H4	ACS0930EU		H4	ACS0933AU
		J	ACS0931EM		J	ACS0934AM

Note: Kits are supplied with connection piece (nut/clamp coupling) and seal. Seal material options are H (Fluorocarbon Elastomer), H4 (Silicone) and J (EPR).



Pall Corporation

Pall Food and Beverage

25 Harbor Park Drive
Port Washington, NY 11050
+1 516 484 3600 telephone
+1 866 905 7255 toll free US
foodandbeverage@pall.com

Portsmouth - UK
+44 (0)23 9230 2269 telephone
+44 (0)23 9230 2509 fax
industrialeu@pall.com

Visit us on the Web at www.pall.com/foodandbev

Pall Corporation has offices and plants throughout the world. For Pall representatives in your area, please go to www.pall.com/contact

Please contact Pall Corporation to verify that the product conforms to your national legislation and/or regional regulatory requirements for water and food contact use.

Because of technological developments related to the products, systems, and/or services described herein, the data and procedures are subject to change without notice. Please consult your Pall representative or visit www.pall.com to verify that this information remains valid.

© Copyright 2010, Pall Corporation. Pall and are trademarks of Pall Corporation. ® indicates a trademark registered in the USA. Filtration. Separation. Solution.SM is a service mark of Pall Corporation. * indicates a trademark of Stäubli. 3-A and the 3-A logo are registered trademarks of 3-A Sanitary Standards Inc.