

Dry Desiccant Dehydration System

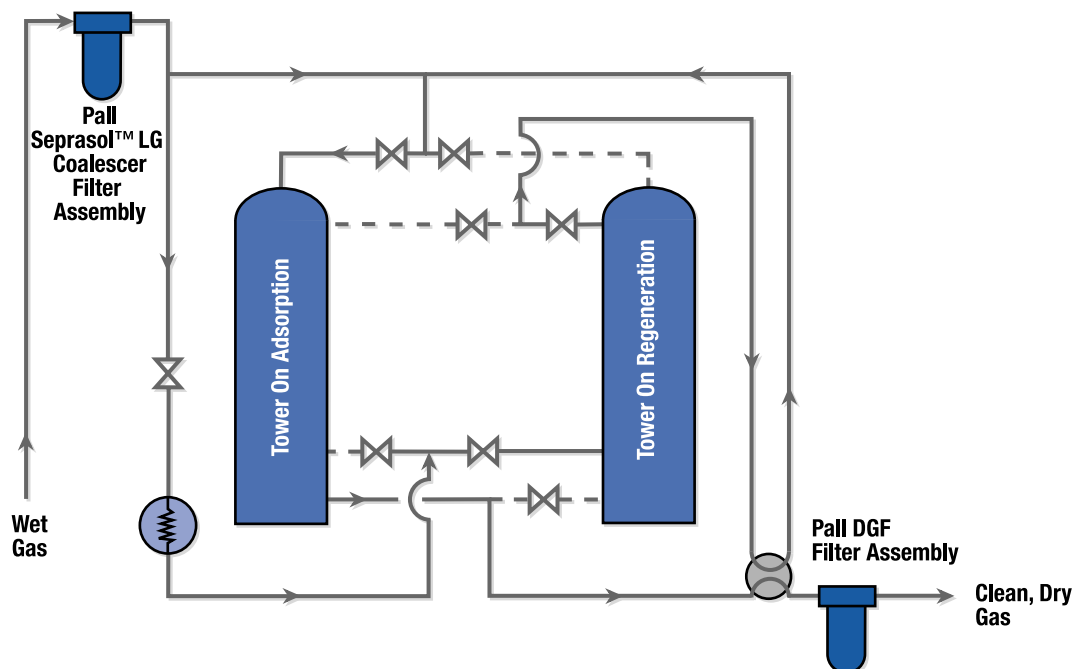

Process Description

The most direct approach to preventing problems associated with water vapor in gas streams is to remove the water from the gas. Dehydration, or the removal of water, prevents formation of gas hydrates and subsequent freezing of critical downstream components, reduces corrosion, maximizes pipeline and process efficiencies, and protects water sensitive catalysts in refinery processes.

In desiccant operations, four general categories of adsorbent materials are available to accomplish dehydration. These include bauxite, alumina, gels and molecular sieves.

The wet hydrocarbon gas enters the top of the adsorption tower and flows downward through the adsorbent where the water is adsorbed. The essentially bone dry hydrocarbon gas exits at the bottom and is ready for processing or sale. Most desiccant systems have two or more adsorption towers enabling one to be regenerated while the remaining tower(s) are in operation. Bed regeneration is accomplished by flowing regeneration gas upward so that contaminants adsorbed near the inlet can

be removed without flushing them through the entire bed. The volume of regeneration gas tends to be 5 to 15 percent of the main inlet wet hydrocarbon gas stream. The entire adsorption/regeneration cycle typically lasts for 8 hours, though other cycle times (6, 12 and 24 hours) are sometimes used.

Need

Adsorber design must consider cycle time, gas flow rate, desiccant capacity, total amount of water to be removed, regeneration requirements and pressure drop limitations. Optimization of these variables will produce the desired degree of dehydration. One major problem, which can lead to off-specification effluent, is bed degradation or loss of capacity.

Degradation occurs as the external surface of the bed becomes coated with foreign material which plugs the pores of the adsorbent and prevents access to the large interior surface. The contaminants, usually arriving as slugs, can include glycol, amine, lube oil, corrosion inhibitors and solids. Protection of the bed is critical, especially if it is downstream of processes which exhibit carryover.

Another cause of degradation is the introduction of large quantities of liquid water which can cause the bed to “explode.” Continuous degradation or breakage of the bed will release desiccant fines downstream, resulting in increased pressure drop, loss of dehydrating capacity, and, in cases where the fines enter the pipeline, compressor damage. To minimize the effects of desiccant fines, protection downstream of the unit is also necessary.

Solution

To prevent liquid fracturing and dusting of the desiccant bed from liquid and solid contaminants entrained in the wet inlet stream, Pall recommends the liquid/gas Seprazol™ LG coalescer filter assembly. This system typically provides liquid aerosol effluent concentrations of less than 0.003 ppmw at a low saturated pressure drop and a particulate removal efficiency of 0.3 microns at greater than 99.97%

efficiency. Because most contaminants enter as slugs rather than at a continuous rate, the Seprazol LG Assembly has a dual sump provision that accepts slugs without filter bypass or loss of removal efficiency. In addition, Pall’s patented oleophobic treated coalescer recovers quickly from the introduction of slugs and minimizes the pressure drop of the assembly. The Seprazol LG coalescer also provides a clean gas stream for regeneration.

To complete the system, Pall recommends protecting downstream equipment and preventing compressor damage and plugging of downstream catalysts by installing the DGF Dry Gas Particulate Filter Assembly. This equipment will remove desiccant fines and other dirt from the dry hydrocarbon gas stream prior to entering the pipeline, compressor, or catalyst bed.



New York - USA

888.873.7255 toll free in the USA
516.484.5400 phone
+01 516 484 0364 fax
fuelsandchemicals@pall.com email

Portsmouth - Europe

023 9230 3303 phone
023 9230 2509 fax
fuelsandchemicals@pall.com email

Visit us on the Web at www.pall.com

Pall Corporation has offices and plants throughout the world in locations including: Argentina, Australia, Austria, Belgium, Brazil, Canada, China, France, Germany, India, Indonesia, Ireland, Italy, Japan, Korea, Malaysia, Mexico, the Netherlands, New Zealand, Norway, Poland, Puerto Rico, Russia, Singapore, South Africa, Spain, Sweden, Switzerland, Taiwan, Thailand, United Kingdom, United States, and Venezuela. Distributors are located in all major industrial areas of the world.

© Copyright 2005, Pall Corporation. Pall, , and Seprazol™ are trademarks of Pall Corporation. ® Indicates a Pall trademark registered in the USA. *Filtration. Separation. Solution.SM* is a service mark of Pall Corporation.