



Pall Corporation

UR219

UR219 Series Filters ULTIPLEAT® SRT RETURN LINE FILTERS Port Size ¾", 1" and 1¼"



Features

- Patented Ultipleat (laid-over pleat) filter medium pack
- Coreless, cageless element configuration
- Pall Stress-Resistant Technology (SRT) Media
- In-to-out filter element flow path
- Flows to 265 L/min (70 US gpm)
- Pressures to 41 bar (600 psi)
- Port size ¾", 1" and 1¼"

Notes and Specifications

Filter Housing

- **Maximum Working Pressure:**
41 bar (600 psi)
- **Rated Fatigue Pressure:**
41 bar (600 psi)
10⁶ cycles per NFPA T2.06.01R2-2001
- **Typical Burst Pressure:**
145 bar (2100 psi)
- **Fluid Compatibility:**
Compatible with all petroleum oils, water glycols, water-oil emulsions and most synthetic hydraulic and lubrication fluids
- **Temperature Range:**
Fluorocarbon Seals:
-29 °C to 120 °C (-20 °F to 250 °F)
60 °C (140 °F) maximum in HWCF or water glycol fluids
- **Materials of Construction:**
Aluminum alloy head, tube and cap

Filter Element

- **Filter Element Burst Pressure:**
10 bard (150 psid)
- **Ultipleat SRT Element Construction:**
Inorganic fibers impregnated and bonded with epoxy resins. Polymer endcaps. Anti-static media design

The equipment has been assessed in accordance with the guidelines laid down in The European Pressure Directive 97/23/EC and has been classified within Sound Engineering Practice S.E.P. Suitable for use with Group 2 fluids only. Consult Sales for other fluid gas group suitability.

Pressure Drop Information

Housing pressure drop using fluid with 0.9 S.G.

Housing pressure drop is directly proportional to specific gravity.

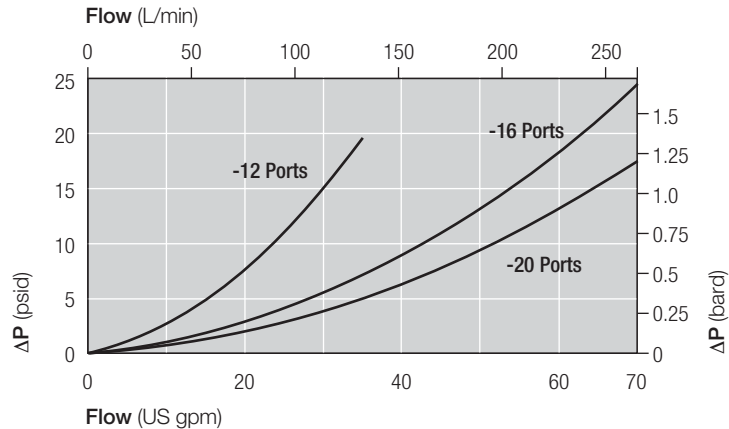

Element Pressure Drop

Multiply actual flow rate times factor in table below to determine pressure drop with fluid at 32 cSt (150 SUS), 0.9 S.G. Correct for other fluids by multiplying new viscosity in cSt/32 (SUS/150) x new S.G./0.9. Note: factors are per 1000 L/min and per 1 US gpm.

219 Series Filter Elements — bard/1000 L/min (psid/US gpm)

Length Code	AZ	AP	AN	AS	AT
04	20.07 (1.102)	8.51 (0.467)	5.72 (0.314)	3.55 (0.195)	2.69 (0.148)
08	9.93 (0.545)	4.21 (0.231)	2.83 (0.155)	1.76 (0.096)	1.33 (0.073)
13	5.95 (0.327)	2.52 (0.139)	1.70 (0.093)	1.05 (0.058)	0.80 (0.044)
20	3.95 (0.217)	1.68 (0.092)	1.13 (0.062)	0.70 (0.038)	0.53 (0.029)

Sample ΔP calculation

UR219 Series 13" length housing with C20 (1¼" BSP) threaded ports using AN grade media. Operating conditions 150 L/min flow rate using a hydraulic fluid of 50 cSt and specific gravity (s.g.) 1.2.

Total Filter ΔP

$$\begin{aligned}
 &= \Delta P_{\text{housing}} + \Delta P_{\text{element}} \\
 &= (0.41 \times 1.2/0.9) \text{ bard (housing)} \\
 &+ ((150 \times 1.70/1000) \times 50/32 \times 1.2/0.9) \text{ bard (element)} \\
 &= 0.55 \text{ bard (housing)} + 0.53 \text{ bard (element)} \\
 &= \mathbf{1.08 \text{ bard (15.7 psid)}}
 \end{aligned}$$

UR219 Series Filters

Ordering Information

For new installations, select one complete part number from each section below

Section 1

Housing P/N:

Note: Pall Ultipleat SRT filter housings are supplied without filter elements or warning devices fitted. Never operate the filter unless a filter element is fitted and all warning device ports are sealed.

Seal Kit P/N:

UR 219   ++  Z  1

Note: Z indicates fluorocarbon seals are standard. Other options are available; contact Pall. The suffix '1' at the end of the Housing P/N designates 1 indicator port fitted with a plug.

UR 219 SKZ

*Other seal material options are available; Contact Pall.

Table 1: Housing Orientation Options

Code	Port
C	Cap service (tube up) -standard
H	Head service (tube down)

Table 2: Housing Port Options

Code	Port
A12	3/4" SAE J514 straight thread
A16	1" SAE J514 straight thread
A20	1 1/4" SAE J514 straight thread
C12	3/4" BSP ISO 228 threads
C16	1" BSP ISO 228 threads
C20	1 1/4" BSP ISO 228 threads

Table 3: Housing Length Options

Code	Length (in)*
04	4
08	8
13	13
20	20

* Nominal length

Table 4: Housing Bypass Valve Options

Code	Valve
A	1.7 bard - 25 psid - Use 084 code indicator only
G	4.5 bard - 65 psid - Use 091 code indicator only
N	Non-Bypass - Use 091 code indicator only

Section 2

Element P/N:

UE 219   Z

Note: Z indicates fluorocarbon seals are standard. Other options are available; contact Pall.

Table 1: Filter Element Options

Code	$\beta_{x(c)} \geq 1000$ based on ISO 16889	CST Rating*
AZ	3	08/04/01
AP	5	12/07/02
AN	7	15/11/04
AS	12	16/13/04
AT	22	17/15/08

* CST: Cyclic Stabilization Test to determine filter rating under stress conditions, based on SAE ARP4205

Table 2: Filter Element Length Options

Code	Length (in)*
04	4
08	8
13	13
20	20

* Nominal length

Section 3 (At least one Differential Pressure Indicator or 'B' type blanking plug must be ordered)

Differential Pressure Indicator P/N:

RC   Z  

Note: If no differential pressure indicator is selected, 'B' type blanking plug (P/N HA9000-P8-Kit Z) must be ordered separately and fitted to replace the plastic shipping plug.

Note: Z indicates fluorocarbon seals are standard. Other options are available; contact Pall.

Table 1: Differential Pressure Indicator Options*

Code	Indicator	'H' Dim.
778NZ	'P' type Visual indicator with thermal lockout	21mm (0.83in)
860MZ	'D' type Visual indicator with no thermal lockout	21mm (0.83in)
861CZ	'L' type Electrical switch (SPDT) with 6" leads	38mm (1.50in)
861CZ	'M' type Electrical switch (SPDT) with DIN43650 connector and matching cap	78mm (3.07in)
861CZ	'R' type Electrical switch (SPDT) and neon light indicator with DIN43650 connector and cap	89mm (3.50in)
771BZ	'S' type Electrical switch (SPDT) with 3-pin MS connector	57mm (2.24in)

* Other options available on application.

Table 2: Indicator Pressure Setting Option*

Code	Valve
084	For 'A' Valve Option - Housings (1.1 bard - 16 psid)
091	For 'G' and 'N' Valve Options - Housings (3.5 bard - 50 psid)

* Other setting options are available; contact Pall.

Table 3: 'M' & 'R'-Type Indicator Codes*

Code	Option
YM	'M' option
YR	'R' option

* Use only if 'R' or 'M' Indicator is selected from Table 1

Table 4: 'R' Indicator Options

Code	Option
110AC	110V AC
220AC	220V AC
24DC	24V DC

* Use only if 'R' Indicator is selected from Table 1

('C' option housing shown)

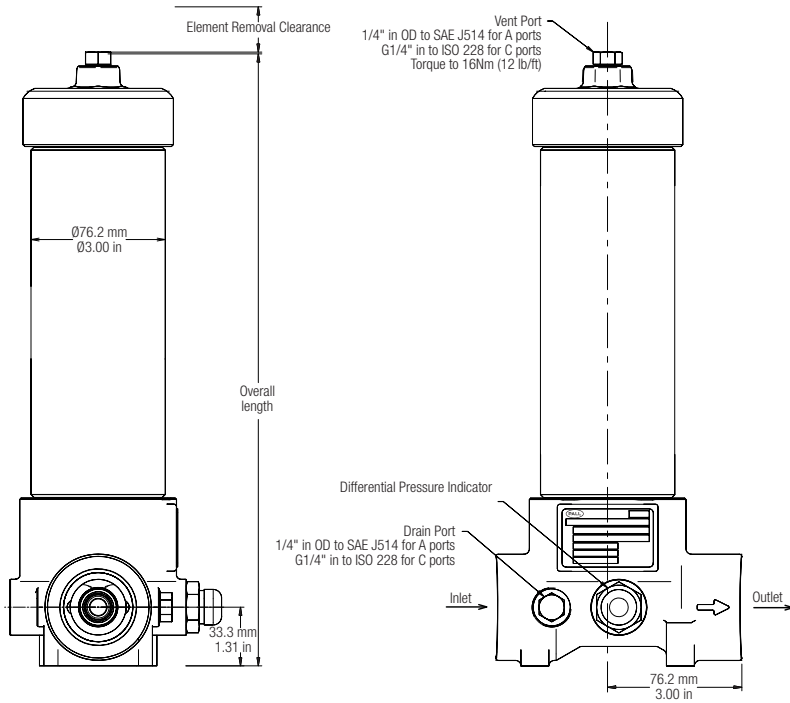

Length Code	'C' Option Overall Length mm (in)	'H' Option Overall Length mm (in)	'C' Option Element Removal Clearance mm (in)	'H' Option Element Removal Clearance mm (in)	Empty Weights kg (lb)
04	246 (9.72)	260 (10.3)	130 (5)	64 (2.5)	2.5 (5.6)
08	348 (13.72)	362 (14.3)	230 (9)	64 (2.5)	3.1 (6.8)
13	483 (19.02)	496 (19.6)	370 (14.5)	64 (2.5)	3.6 (7.9)
20	653 (25.72)	667 (26.3)	530 (21)	64 (2.5)	3.9 (8.5)

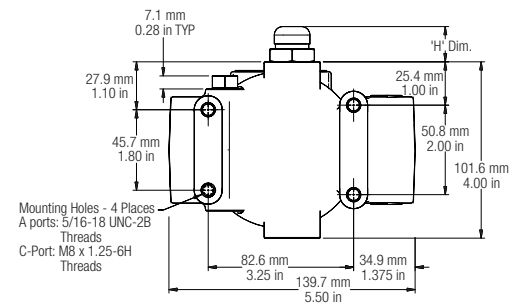

Pall Industrial Manufacturing

25 Harbor Park Drive
Port Washington, NY 11050
+1 516 484 3600 telephone
+1 800 289 7255 toll free US

Portsmouth-UK
+44 (0)23 9230 3303 telephone
+44 (0)23 9230 2507 fax



Visit us on the Web at www.pall.com

Pall Corporation has offices and plants throughout the world. For Pall representatives in your area, please go to www.pall.com/contact

Because of technological developments related to the products, systems, and/or services described herein, the data and procedures are subject to change without notice. Please consult your Pall representative or visit www.pall.com to verify that this information remains valid. Products in this document may be covered by one or more of the following patent numbers: EP 667,800; EP 982,061; EP 1,380,331; EP 1 656 193; US 5,543,047; US 5,690,765; US 5,725,784; US 6,113,784; US 7,083,564; US 7,318,800; US 7,871,515.

© Copyright 2011, Pall Corporation. Pall, , and Utiplateat are trademarks of Pall Corporation. ® indicates a trademark registered in the USA. ENABLING A GREENER FUTURE and Filtration. Separation. Solution.sm are service marks of Pall Corporation.