



Pall Corporation

UT319

UT319 Series Filters

ULTIPLEAT® SRT IN-TANK FILTERS

Port Size 1½", 2" and 2½"



Features

- Patented Ultipleat (laid-over pleat) filter medium pack
- Coreless, cageless element configuration
- Pall Stress-Resistant Technology (SRT) Media
- In-to-out filter element flow path
- Flows to 760 L/min (200 US gpm)
- Pressures to 10 barg (150 psid)
- Port size 1½", 2" and 2½"

Notes and Specifications

Filter Housing

- **Maximum Working Pressure:**
10 barg (150 psid)
- **Fluid Compatibility:**
Compatible with all petroleum oils, water glycols, water-oil emulsions and most synthetic hydraulic and lubrication fluids
- **Temperature Range:**
Fluorocarbon Seals:
-29 °C to 120 °C (-20 °F to 250 °F)
60 °C (140 °F) maximum in HWCF or water glycol fluids
- **Materials of Construction:**
Die cast aluminum alloy head, and cover, steel shell. Use YR85 option for cast iron head and cover

Filter Element

- **Filter Element Burst Pressure:**
10 barg (150 psid)
- **Ultipleat SRT Element Construction:**
Inorganic fibers impregnated and bonded with epoxy resins. Polymer endcaps. Anti-static media design

Pressure Drop Information

Housing pressure drop using fluid with 0.9 S.G.

Housing pressure drop is directly proportional to specific gravity..

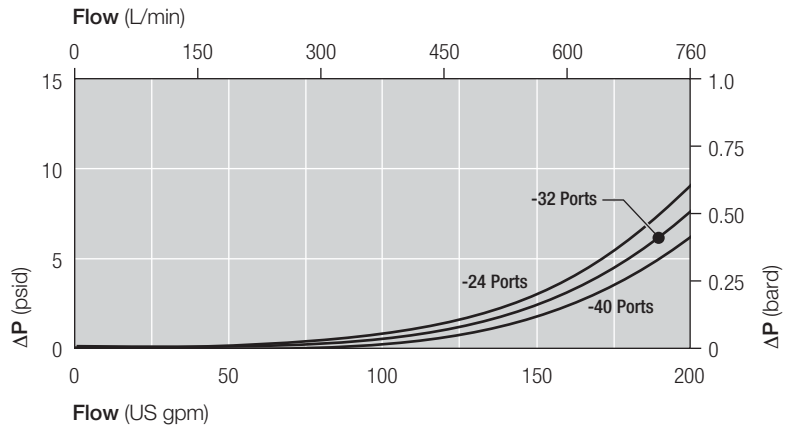

Element Pressure Drop

Multiply actual flow rate times factor in table below to determine pressure drop with fluid at 32 cSt (150 SUS), 0.9 S.G. Correct for other fluids by multiplying new viscosity in cSt/32 (SUS/150) x new S.G./0.9. Note: factors are per 1000 L/min and per 1 US gpm.

319 Series Filter Elements — barg/1000 L/min (psid/US gpm)

Length Code	AZ	AP	AN	AS	AT
08	5.52 (0.302)	2.30 (0.126)	1.82 (0.100)	1.32 (0.072)	0.82 (0.045)
13	3.31 (0.182)	1.38 (0.076)	1.09 (0.060)	0.79 (0.043)	0.49 (0.027)
20	2.18 (0.120)	0.91 (0.050)	0.72 (0.040)	0.52 (0.029)	0.33 (0.018)
40	1.10 (0.060)	0.46 (0.025)	0.36 (0.020)	0.26 (0.014)	0.16 (0.009)

Sample ΔP calculation

UT319 Series 13" length housing with F24 (1 1/2"SAE) split flange ports using AN grade media. Operating conditions 200 L/min flow rate using a hydraulic fluid of 50 cSt and specific gravity (s.g.) 1.2.

Total Filter ΔP

$$\begin{aligned}
 &= \Delta P \text{ housing} + \Delta P \text{ element} \\
 &= (0.05 \times 1.2/0.9) \text{ barg (housing)} \\
 &+ ((200 \times 1.09/1000) \times 50/32 \times 1.2/0.9) \text{ barg (element)} \\
 &= 0.07 \text{ barg (housing)} + 0.45 \text{ barg (element)} \\
 &= \mathbf{0.52 \text{ barg (7.6 psid)}}
 \end{aligned}$$

The equipment has been assessed in accordance with the guidelines laid down in The European Pressure Directive 97/23/EC and has been classified within Sound Engineering Practice S.E.P. Suitable for use with Group 2 fluids only. Consult Sales for other fluid gas group suitability.

UT319 Series Filters

Ordering Information

For new installations, select one complete part number from each section below

Section 1

Housing P/N:

Note: Pall Utlepleat SRT filter housings are supplied without filter elements or warning devices fitted. Never operate the filter unless a filter element is fitted and all warning device ports are sealed.

UT 319 ++ Z BN B

Table 1 Table 2 Table 3 Table 4 Table 5

Note: Z indicates fluorocarbon seals are standard. Other options are available; contact Pall.
'BNB' at the end of the Housing P/N designates 1 gauge port, and one indicator port, both fitted with plugs.

Seal Kit P/N:

UT 319 SKZ

*Other seal material options are available; Contact Pall.

Table 1: Housing Port Options

Code	Port
A24	1½" SAE J514 straight thread
D24	1½" Flange J518C code 61 with ½"-13 UNC holding bolts
A32	2" SAE J514 straight thread
D32	2" Flange J518C code 61 with ½"-13 UNC holding bolts
A40	2½" SAE J514 straight thread
D40	2½" Flange J518C code 61 with ½"-13 UNC holding bolts
C24	1½" BSP ISO 228 threads
F24	1½" ISO 6162 split flange with M12 x 1.75 holding bolts
C32	2" BSP ISO 228 threads
F32	2" ISO 6162 split flange with M12 x 1.75 holding bolts

Table 2: Housing Length Options

Code	Length (in)*
08	8
13	13
20	20
40	40

* Nominal length

Table 3: Bypass Valve Options

Code	Valve
A	1.7 bard (25 psid) with shroud
G	4.5 bard (65 psid) with shroud
3	4.5 bard (65 psid) with cannister, no ABFV
7	4.5 bard (65 psid) with cannister & ABFV

Table 4: Secondary Port Options

Code	Port
N	No secondary port
S	1¼" port (same style as primary port)

Table 5: Head Material

Code	Material
OMIT	Cast aluminum alloy (standard)
YR85	Cast iron

Section 2

Element P/N:

UE 319 Z

Table 1 Table 2

Note: Z indicates fluorocarbon seals are standard. Other options are available; contact Pall.

Table 1: Filter Element Options

Code	$\beta_{x(c)} \geq 1000$ based on ISO 16889	CST Rating*
AZ	3	08/04/01
AP	5	12/07/02
AN	7	15/11/04
AS	12	16/13/04
AT	22	17/15/08

* CST: Cyclic Stabilization Test to determine filter rating under stress conditions, based on SAE ARP4205

Table 2: Filter Element Length Options

Code	Length (in)*
08	8
13	13
20	20
40	40

* Nominal length

Section 3

Differential Pressure Indicator P/N:

RC Z

Table 2 Table 3 Table 4

Note: Z indicates fluorocarbon seals are standard. Other options are available; contact Pall.

Gauge/Switch P/N: See Table 1

Table 2: Differential Pressure Indicator Options

Code	Indicator	'H' Dim.
778NZ	'P' type Visual indicator with thermal lockout	21mm (0.83in)
860MZ	'D' type Visual indicator with no thermal lockout	21mm (0.83in)
861CZ	'L' type Electrical switch (SPDT) with 6" lead	38mm (1.50in)
861CZ	'M' type Electrical switch (SPDT) with DIN43650 connector and matching cap	78mm (3.07in)

* Other options available on application.

Table 3: Indicator Pressure Setting Options*

Code	Pressure Setting
084	For 'A' Valve Option Housings (1.1 bard - 16 psid)
091	For 'G', '3' and '7' Valve Option Housings (3.5 bard - 50 psid)

* Other setting options are available; contact Pall.

Table 4: 'M' Type Indicator Code*

Code	Option
YM	'M' option

* Use only if 'M' Indicator is selected from Table 8

Table 1: Gauge / Switch Options

Part No	Rating	Indicator	'H' Dim
1373772	-	'B' option 1/8" blanking plug	3mm (0.1in)
9004D370-11	0-10 bard (150 psid)	'A' type Pressure Gauge	32mm (1.3in)
9004D370-34	0-10 bard (150 psid)	'G' type Pressure Gauge	32mm (1.3in)
HC0379-11	1.1 bard (16 psid)	Electrical absolute pressure switch 24VDC	54mm (2.1in)
HCA132-35	3.5 bard (50 psid)	Electrical absolute pressure switch	83mm (3.25in)
HC0618-11	1.1 bard (16 psid)	220VAC with Hirschmann connector	55mm (2.2in)
HC0618-35	3.5 bard (50 psid)	Electrical absolute pressure switch	55mm (2.2in)
HC0380-11	1.1 bard (16 psid)	220VAC with 3 (15") flying leads	
HC0380-35	3.5 bard (50 psid)		

Note: Use 1.1 bar rating for A valve options
Use 3.5 bar rating for G, 3 and 7 valve options

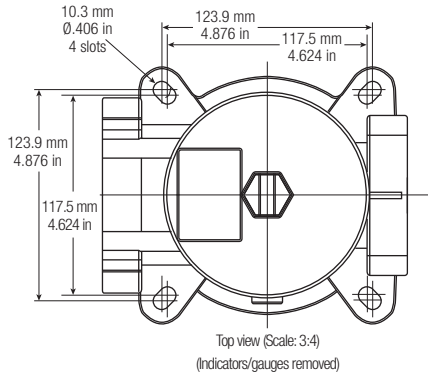

Length Code	In-tank Length mm (in)		Element Removal Clearance mm (in)
	'C' Option	'S' Option	
08	337 (13.25)	295 (11.62)	229 (9)
13	464 (18.25)	422 (16.62)	361 (14.2)
20	641 (25.25)	600 (23.62)	533 (21)
40	1149 (45.25)	1108 (43.62)	1041 (41)

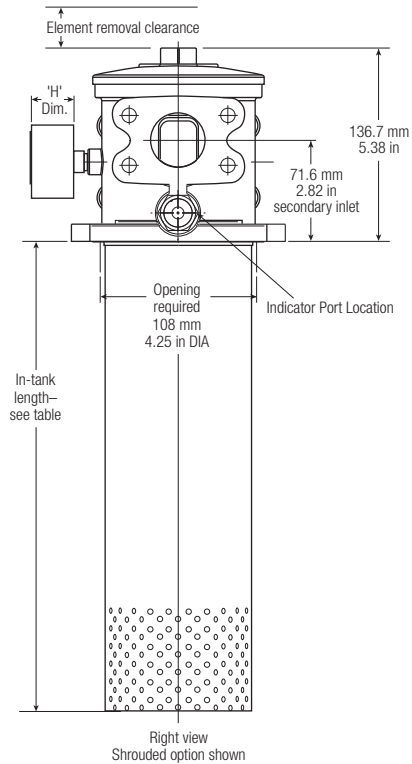
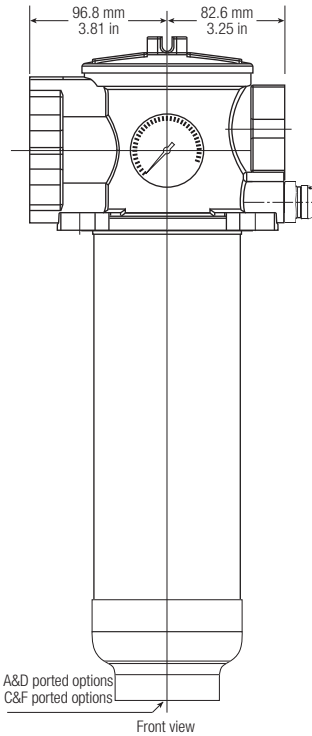
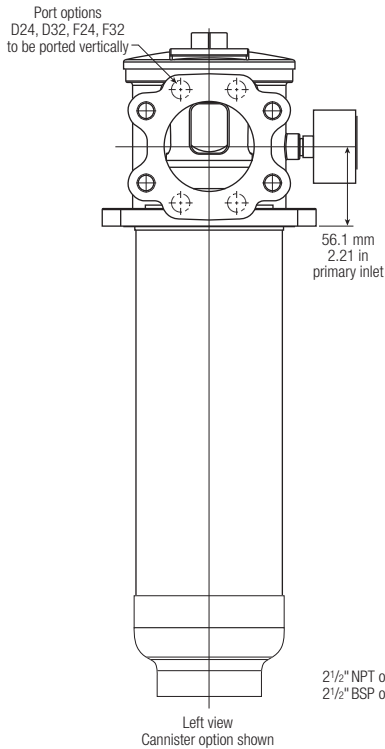

Pall Industrial Manufacturing

25 Harbor Park Drive
Port Washington, NY 11050
+1 516 484 3600 telephone
+1 800 289 7255 toll free US

Portsmouth-UK
+44 (0)23 9230 3303 telephone
+44 (0)23 9230 2507 fax

Visit us on the Web at www.pall.com

Pall Corporation has offices and plants throughout the world. For Pall representatives in your area, please go to www.pall.com/contact

Because of technological developments related to the products, systems, and/or services described herein, the data and procedures are subject to change without notice. Please consult your Pall representative or visit www.pall.com to verify that this information remains valid. Products in this document may be covered by one or more of the following patent numbers: EP 667,800; EP 982,061; EP 1,380,331; EP 1 656 193; US 5,543,047; US 5,690,765; US 5,725,784; US 6,113,784; US 7,083,564; US 7,318,800.

© Copyright 2009, Pall Corporation. Pall, and Upleteq are trademarks of Pall Corporation. ® Indicates a trademark registered in the USA. *Filtration. Separation. Solution.sm* is a service mark of Pall Corporation.