

6.1 Evaluation of Chromatography Column Packing Efficiency

The evaluation of a column's packing efficiency (HETP and peak asymmetry) can provide valuable knowledge about a column's performance and stability during a purification run. The HETP (height equivalent of a theoretical plate) and asymmetry values are obtained using the protocol described below. Typically, the test method employs a sample of 5% (v/v) acetone (measured by absorbance at 280 nm) and/or 0.5 M NaCl (conductivity) corresponding to a 0.5% (v/v) of the total column volume.

Protocol for Evaluation of Chromatography Column Packing Efficiency

A. Materials Required

1. Packed glass 1-2 mL column with adjustable flow adapter
2. Equilibration buffer for the resin to be evaluated
3. 5% acetone in water
4. 0.5 M NaCl in equilibration buffer
5. Liquid chromatography workstation able to pump up to 20 mL/min and measure the A_{280} and conductivity

B. Column Packing Efficiency Protocol

1. Mount packed 1-2 mL column on a liquid chromatography workstation and ensure that all connections are liquid tight and all air bubbles have been purged from the system.
2. Equilibrate the column for 5 column volumes (CV) at the maximum flow rate you plan to operate the column and adjust the flow adapter to remove any voids that may develop on the head of the column.
3. Reduce flow rate to 0.3-1.0 mL/min and allow the system to stabilize for 1-2 CV. Record the pressure of the system.
4. Ramp up the flow rate and measure the pressure flow characteristics of the packed bed. A typical pressure vs. flow curve for Q Ceramic HyperD® F resin is shown in Figure 6.1.

Figure 6.1

Pressure vs. Flow Rate Curve for Q Ceramic HyperD® F

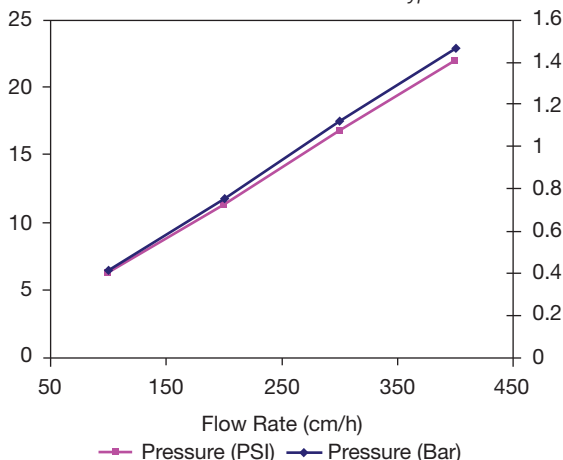

Pressure vs. flow rate curve generated for a 1 x 15 cm column packed with Q Ceramic HyperD F resin.

6.1 – Section 6.1

5. Reduce flow rate to 0.3-1.0 mL/min and allow the system to stabilize for 1-2 CV.
6. Continue running the column with equilibration buffer at a fixed flow rate and inject 0.2 mL of acetone or NaCl or both and monitor absorbance at 280nm and conductivity (mS/cm).

Note: HETP can be influenced by flow rate. The slower the velocity, the more uniformly analyte molecules may penetrate inside the particle, and the less different penetration affects efficiency. On the other hand, at the faster flow rates, the elution distance between molecules with different penetration depths will be high. For more detailed analysis (optional), HETP can be measured over a range of flow rates and the data fitted to the Van Deemter equation; $H = A + B/u + C u$ where u (cm s⁻¹) is the average velocity of the mobile phase and A, B, C are factors which contribute to band broadening.

7. Plot out the absorbance or conductivity trace and calculate HETP (as cm/plate) using the following equation;

$$\text{HETP} = \frac{d^2 \times L}{5.54 \times t^2}$$

Where: t = retention value of acetone or NaCl peak expressed as units of time, volume or measured distance on the Chromatogram
 d = peak width at half height expressed in same units as “ t ”
 L = column length (in units of cm for HETP or m for N/m)

8. Calculate the number of plates (N/m) with the following equation:

$$N/m = \frac{5.54 \times t^2}{d^2 \times L}$$

9. Calculate the peak asymmetry factor (AF) with the following equation:

$$\text{AF} = \frac{b}{a}$$

Where: a is the peak width (left half) at 10% of peak height, b is the peak width (right half) at 10% of peak height, Typical values for N/m are 2,500-4,000 plates/meter with a peak asymmetry factor range of 0.8-2.0.

Application Data for Evaluation of Chromatography Column Packing Efficiency

Using a packed 1 mL volume glass column of Q HyperD® F resin, HETP was estimated at 1 mL/min flow rate using acetone. An example of the resulting chromatogram is shown in Figure 6.2. The acetone peak result showed a slight asymmetry (AS ratio 1.7) indicative of some slight tailing with an HETP of 0.0647 (cm/plate) and a plate count of 1545 (N/m). The plate count for this column is slightly less than the typical range and may reflect a slight loss in efficiency by operation of the column at a high flow rate (258 cm/h). Initial studies are usually carried out at 100 cm/h where the HETP and plate count will be optimal. Nevertheless, this column would be acceptable for use in an ion exchange purification process.

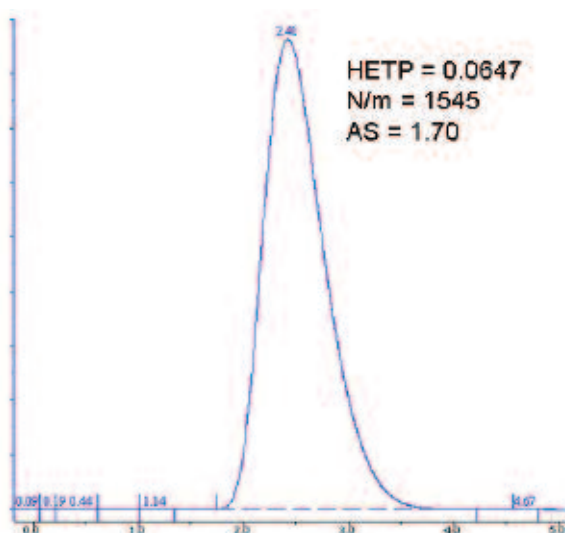
Figure 6.2*HETP Profile on a Q Ceramic HyperD F Resin Column*

HETP profile measured on a 0.66 x 2.8 cm (1.0 mL volume) column packed with Q Ceramic HyperD F resin equilibrated in 50 mM Tris HCl pH 8.0 at 1 mL/min (258 cm/h linear velocity).

6.2 – Section 6.2

6.2 Optional Pre-Treatment to Improve Recovery of Samples from Ultrafiltration Spin Filters

Poor sample recovery may be experienced with the Omega™ UF membranes and devices because of non-specific adsorption. It is possible to pre-treat these membranes and devices with protein or detergents to reduce the potential for non-specific adsorption of the target analyte. A protocol is outlined below.

Protocol for Optional Pre-Treatment to Improve Recovery of Samples from Ultrafiltration Spin Filters

- A.** Add sufficient volume of one of the following:
 - 1.** 1% (w/v) BSA
 - 2.** 1% (w/v) IgG in phosphate buffered saline (PBS)
 - 3.** 5% (w/v) SDS
 - 4.** 5% (v/v) Tween-20
 - 5.** 5% (v/v) Triton*-X100
 - 6.** 5% (w/v) PEG compound in high purity water to partially fill the UF device.
- B.** Close the cap and mix by inversion to coat the solution over the internal surfaces of the device.
- C.** Incubate the solution in the device for at least one hour at room temperature.
- D.** Discard the above solution by pouring it out of the device, and rinse the device thoroughly with high purity water.

Tip: *Rinsing to remove detergents such as SDS, Tween, and Triton may require more than the above wash steps.*

- E.** To ensure that pre-treatment solution is removed from the membrane, add high purity water to the device and spin at the recommended speed for each device to pass the fluid through the UF membrane. Discard the filtrate.
- F.** The device can be used immediately or stored for later use. If the device is to be used later, add sterile high purity water (rendered sterile by autoclaving or filtration with a 0.2 µm sterilizing grade filter [see Acrodisc® syringe filters with Supor® PES membrane for sterile filtration (PN 4612)] to the sample reservoir and store at 4 °C to retard bacterial growth.

Tip: *Do not allow the membrane to dry out once the device has been pre-treated.*

6.3 Vacuum Manifold for Use with Multi-Well Filter Plates

The multi-well plate vacuum manifold is an anodized aluminum manifold that has been designed and optimized for the vacuum filtration of the AcroPrep® and AcroWell™ lines of multi-well filter plates. The vacuum manifold comes complete with the necessary O-ring and gasket. The control block includes the vacuum pressure gauge, vacuum metering valve, vacuum release valve, and the 1/4 inch hose barb for vacuum line attachment. Included with the vacuum manifold unit is a Delrin spacer block designed to accommodate standard 350 µL receiver plates. The spacer block has been optimized to reduce the space between the receiver plate and the filter plate during vacuum filtration. An accessory kit that contains an additional O-ring, gasket, and allen wrench is also included with the vacuum manifold unit.

Table 6.1

Specifications for the Multi-Well Plate Vacuum Manifold

Specification	Parameter
Materials of Construction	
Vacuum Manifold	Anodized aluminum
Gasket	EPDM (Ethylene propylene)
O-ring	Silicone
Spacer blocks	Delrin
Dimensions	
Length	17.48 cm (6.88 in)
Width	12.37 cm (4.87 in)
Height	8.05 cm (3.17 in)
Weight	6.27 lbs
Maximum Operating Vacuum	71.12 cm Hg (28 in. Hg).

Tip: *The multi-well plate vacuum manifold can be used with multi-well filter plates that meet the specifications set forth by the Society for Biomolecular Screening (SBS).*

6.3 – Section 6.3

Protocol for Vacuum Manifold for Use with Multi-Well Filter Plates

A. Set the Vacuum Manifold to a Desired Negative Pressure Setting Prior to Filtration

1. Switch the on/off valve to the off position (see Figure 6.3).
2. Attach the vacuum line to the 1/4 inch hose barb.
3. Place a receiver plate on top of the vacuum manifold.
4. Turn on the vacuum pressure.
5. Adjust the negative pressure to the desired setting by adjusting the metering valve.
6. Turn off the vacuum pressure and remove the receiver plate. The vacuum manifold is now set at the desired setting.

B. Filter Using the AcroPrep® or AcroWell™ Filter Plates

1. If collecting the filtrate, remove the top chamber of the vacuum manifold. The indentations on the sides of the manifold allow for the top portion of the manifold to be easily removed. If collecting the retentate, skip to Step 3.
2. Place the appropriate spacer block into the lower chamber of the vacuum manifold. The vacuum manifold can be used with any size receiver plate.
 - a. 350 μ L receiver plates: to use a 350 μ L receiver plate, place the large spacer block (PN 5015) into the lower chamber of the vacuum manifold. Place the 350 μ L receiver plate on top of the spacer block.
 - b. 1 mL receiver plates: to use 1 mL receiver plates, place the small spacer block (PN 5014) into the lower chamber of the vacuum manifold. Place the 1 mL receiver plate on top of the spacer block. (You can also use a standard 350 μ L receiver plate in plate of the 1 mL spacer block.)
 - c. 2 mL receiver plates: to use 2 mL receiver plates, place the 2 mL receiver plate directly into the lower chamber of the vacuum manifold.
3. Before replacing the top chamber of the vacuum manifold, ensure that all surfaces are free from dirt, debris, and any particulate matter that may have accumulated on the vacuum manifold, O-ring, and gasket.

Tip: *If the O-ring and gasket are not clean, you will not obtain a proper seal.*

4. Replace the top chamber of the vacuum manifold.
5. Place the filter plate on the gasket located on the top chamber of the vacuum manifold. Ensure that the gasket is clean.
6. Ensure that the on/off switch is in the Off position (see Figure 6.3).
7. Connect the vacuum line to the 1/4 inch hose barb.
8. When ready to evacuate the filter plate, turn the on/off switch on the vacuum manifold to the On position. You may need to press lightly on the filter plate to engage the vacuum seal.
9. The wells will begin to evacuate/empty once the vacuum has been applied to the chamber.
10. If you need to adjust the vacuum pressure up or down, adjust by moving the metering valve located to the right of the vacuum pressure gauge.

11. When all of the wells have completely evacuated, turn the on/off valve to the Off position. To release the residual vacuum pressure that remains in the chamber, push the release valve located to the left of the vacuum gauge. The release valve will allow the pressure within the manifold chamber to return to atmospheric pressure and reduce the potential for cross-contamination and spraying of the filtrate. Do not release the vacuum by pulling the corner of the plate as it will degrade the manifold gasket. You can also tap the top of the filter plate prior to removing it to release any hanging drops that may be on attached to the outlet tips.
12. Remove the filter plate and place it aside for further processing or dispose of it properly.
13. If collecting the filtrate, remove the top chamber of the vacuum manifold from the lower portion of the vacuum manifold.
14. Remove the receiver plate from the lower chamber of the vacuum manifold and utilize the filtrate for further processing.

C. Replace the O-ring

1. Remove existing O-ring from the bottom of the upper chamber.
2. Ensure that the O-ring is free from dirt, debris, and particulate matter.
3. Place new O-ring into place.

D. Replace the Gasket

1. With the allen wrench provided, remove the 12 screws located on the bottom portion of the upper chamber.
2. Separate the top ring from the bottom section of the upper chamber.
3. Remove the old gasket and clean the gasket pocket area of any dirt and debris.
4. Place the new gasket into the gasket pocket. Place the top ring back onto the bottom section of the upper chamber. Ensure that the alignment posts on the bottom section fit into the alignment holes in the top ring.
5. Invert the upper chamber and replace the 12 screws.
6. Lightly tighten the four corner screws with the allen wrench, then tighten all 12 screws. Once this is completed, recheck the screws with the allen wrench to ensure that all screws are tightly secured.
7. The manifold is now ready for use.

VACUUM MANIFOLD FOR USE WITH MULTI-WELL FILTER PLATES

6.3 – Section 6.3

Figure 6.3

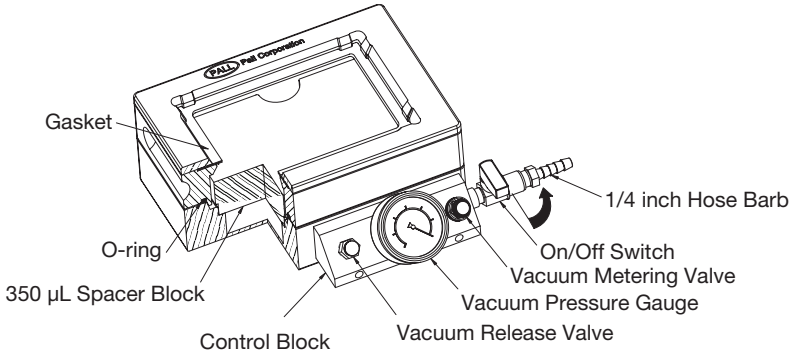

Figure 6.4

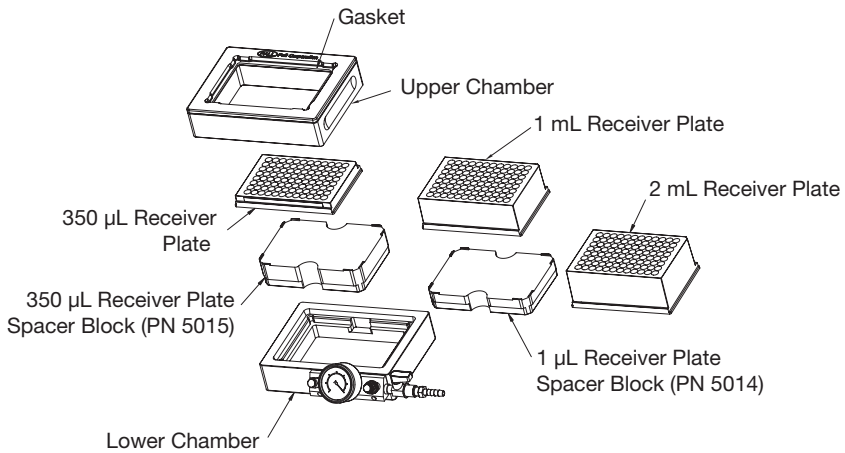
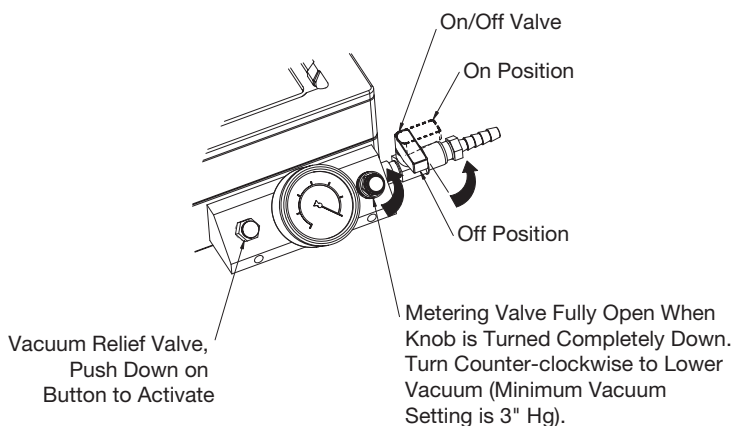

Figure 6.5



Complementary Products for Vacuum Manifold for Use with Multi-Well Filter Plates

AcroWell™ 96-well filter plates with BioTrace™ NT and BioTrace PVDF membranes exhibit high binding capacities for proteins and nucleic acids.

AcroPrep® 96 and 384-well filter plates are an excellent platform for a wide variety of molecular biology, analytical, and high throughput sample preparation and detection applications.

Ordering Information for Purification on an Acrodisc® Unit with Mustang® Q Membrane

Part Number	Description	Pkg
5017	Multi-well Plate Vacuum Manifold	1/pkg
5014	1 mL Receiver Plate Spacer Block	1/pkg
5015	350 µL Receiver Plate Spacer Block	1/pkg
5016	Replacement Accessory Kit (Includes O-Ring, gasket, and allen wrench)	1/pkg

6.4 – Section 6.4

6.4 General Filtration Procedures for AcroPrep and AcroWell Filter Plates

As samples get smaller and more numerous, the need for novel methods to purify proteins and improve assays has led Pall to develop a broad line of multi-well filter plates that target specific application challenges. AcroPrep and AcroWell filter plates feature individually sealed membranes that eliminate crosstalk and solution weeping. The proprietary sealing technology allows us to seal virtually any type of membrane or media configuration into a device platform to meet ever-changing industry needs.

The unique nature of protein science results in a variety of device requirements for each application type. Pall understands this need and has a full portfolio of 96- and 384-well filter plates that can be optimized for your assay. Our portfolio includes a selection of single- and multi-layer membranes, plate colors, well volumes, and outlet tips.

Pall's filter plate product line includes two platforms that address different application needs:

- 1.** AcroPrep filter plates are engineered with special outlet tips and splash guards, and can be used for both filtrate- and retentate-based applications. Membranes are individually cut, placed, and sealed in the wells using a proprietary sealing process that ensures seal integrity. A distinctive valve technology eliminates sample leaking.
- 2.** AcroWell filter plates are designed to support retentate and hybridization-based binding applications. These plates are constructed of two membrane layers; the bottom layer protects the upstream functional membrane and acts as a barrier to passive flow.

Using a plate optimized for your application will reduce sample loss, make automation easy, and add consistency and reliability throughout your entire process.

Automation Compliant

Pall's plates are designed in accordance with the standards of the ANSI/SBS X-2004. Rigid construction enables the plates to be easily maneuvered by robotic instrumentation and assures that the plates will seal properly on vacuum manifolds, wash stations, hotel carousels, and deck platforms. Plates are compatible with industry leading workstations including: Tecan, Qiagen Inc., Tomtec, PerkinElmer Life and Analytical Sciences, Beckman Coulter Inc., Caliper Life Sciences, Inc., Waters, Proteodyne, and Hamilton Company.

Mass Spec Friendly, Chemically Resistant, and Low Binding

The polypropylene housing assembly has been tested to ensure that the materials of construction do not contribute to ion suppression/enhancement. In addition, the housing materials and media have been optimized and tested to reduce extractables, ensuring that unwanted materials are not introduced to your sample. The housing is compatible with a broad range of aqueous and organic liquids, and is noted for its low biomolecule binding that minimizes nonspecific adsorption of samples to the plates.

No Crosstalk

Specially engineered fluid directors and outlet tips on the bottom of the AcroPrep plate are designed to reduce the potential for downstream crosstalk. Elimination of crosstalk upstream is assured through individually sealing a membrane in each well using Pall's proprietary sealing technology. Pall understands the critical nature of each sample, and we know that seal failure will cause sample loss. To ensure integral sealing of each well, we test each lot of product for seal integrity prior to release. You can be assured that AcroPrep and AcroWell filter plates will provide a robust platform that will eliminate concerns of sample loss and cross-contamination.

Figure 6.6

Methodology: Filtration vs. Retention



1. Place plate on vacuum manifold or hold the plate so the outlets on the bottom of the plate are not touched.
2. Add sample and incubate. Apply vacuum (or centrifuge).
- 3A. Release vacuum from the manifold. Remove filter plate and retained sample for further processing. (Or, 3B)
- 3B. Release vacuum from the manifold. Remove filter plate. Remove collection (receiver) plate and utilize collected filtrate in downstream applications.

Protocol for General Filtration Procedures for AcroPrep and AcroWell Filter Plates

A. Vacuum Manifold Filtration

1. During use, hold the filter plate so the membrane at the bottom is not touched or scratched. (Avoid contact between the membrane and other surfaces during incubation to prevent liquid flow due to contact wicking.)
2. Place a collection plate into the vacuum manifold sized to receive the volume of filtrate expected from the filter plate
3. Place the filter plate on the vacuum manifold.

Tip: Plates with BioTrace™ PVDF membrane (PN 5023, 5026, 5027) require pre-wetting with 0.1 mL pure methanol, 2-propanol, or 70% ethanol.

Do not let the membrane dry or pre-wetting will need to be repeated.

Adaptors exist for fitting non-Pall filter plates onto the Pall manifold, as well as, adaptors for fitting Pall filter plates onto non-Pall manifolds. Please contact Pall for more information.

4. After wetting, apply vacuum and rinse with 0.1 mL water or buffer.
5. Add the sample to be filtered to the plate. Incubate if required.

6.4 – Section 6.4

6. Apply vacuum to manifold to initiate liquid flow. Recommended vacuum is 25.4 cm Hg (10 in. Hg); DO NOT exceed 38.1 cm Hg (10 in. Hg); most house vacuum and aspirators do not exceed 38.1 cm Hg (15 in. Hg).
7. Gently tap the plate to remove any hanging droplets.
8. Release vacuum from the manifold. DO NOT RELEASE VACUUM BY PULLING THE CORNER OF PLATE AS IT WILL DEGRADE THE MANIFOLD GASKET.
9. If needed, add wash solutions and filter as needed.

B. Filtration Facilitated by Centrifugation in a Swinging Bucket Rotor

1. Place the filter plate on top of a suitably sized receiver plate.
2. Insert the plates into a standard multi-well plate swinging bucket rotor assembly.
3. Place a duplicate pair of plates matching the weight of the test plate (add water to the receiver plate and match weight of the test plate).

Tip: An imbalance can result with a single test plate if no counter-balancing plate is used. If different volumes of sample are used in multiple plates, they will need to be balanced in pairs by addition of water to empty wells.

4. Centrifuge at 500-3,000 x g for 1-2 minutes.

Tip: The g and time parameters can be varied to optimize the residence time of fluids in contact with the material in the well of the plate.

5. If needed, add wash solution(s) and repeat. Ensure that plates are in balance before centrifugation.

Figure 6.7

AcroPrep or AcroWell Filter Plate... What's the Difference?



AcroPrep Filter Plate

- Membranes are individually cut, placed, and sealed in the wells.
- Plate can be used in both filtrate and retentate-based applications.
- Plates have either long or short fluid directors to direct the flow of the filtrate without cross-contamination.
- Proprietary sealing process allows flexibility in sealing a wide range of membranes both single and multiple layers.
- Available in a wide range of configurations to meet various application challenges.

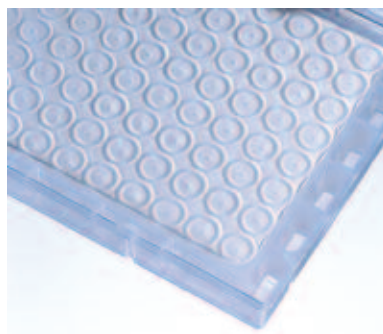

AcroWell Filter Plate

- Constructed of two membrane layers—the bottom layer of membrane protects the upstream membrane and acts as a barrier to passive flow.
- Designed for use in retentate-based applications such as hybridization-based binding assays and time-resolved fluorescence.
- Plate and membrane construction allows for extended or elevated temperature incubations without solution weeping and crosstalk.

6.4 – Section 6.4

Figure 6.8
Various Outlet Tips

AcroWell 96



Used for retentate-based applications. Not recommended for filtrate collection.

AcroPrep 96



Used for both filtrate- and retentate-based applications. Outlet tips are recessed beneath the skirt of the plate.

**AcroPrep 96
1 mL**

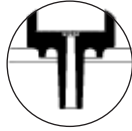

Used for both filtrate- and retentate-based assays. Outlet tips extend beyond the skirt of the plate and pilot into the wells of a receiving plate.

**AcroPrep 384
Long Tip**



Can be used for both filtrate- and retentate-based applications. Outlet tips extend beyond the skirt of the plate and pilot into the wells of a receiving plate.

**AcroPrep 384
Short Tip**

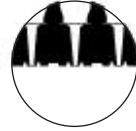

Can be used for both filtrate- and retentate-based applications. Outlet tips are recessed beneath the skirt of the plate.

6.5 Chromatography Products Selection Guide

Chromatography Type	Product	Description	Particle Size (Average)	Capacity	Primary Applications
Size Exclusion (Gel Filtration)					
Separation by Molecule Size	Bulk Resin				
	Ultrogel® AcA	Ultrogel AcA are polymeric resins for size exclusion composed of polyacrylamide and agarose, characterized by narrow particle size distribution.	100 µm	N/A	Fractionation, purification of biomolecules by size, molecular weight determination
	Trisacryl® GF05 M	Trisacryl GF are highly hydrophilic copolymer resins designed for medium pressure gel filtration.	60 µm	N/A	Lowest exclusion limit for desalting and other small molecule removal
	Trisacryl GF2000 LS	Trisacryl GF are highly hydrophilic copolymer resins designed for medium pressure gel filtration.	120 µm	N/A	Purification of macromolecules
Ion Exchange					
Separation by Charge	Bulk Resin				
	Q Ceramic HyperD® 20	Strong anion exchanger. Ceramic HyperD ion exchangers employ a high capacity hydrogel polymerized within the large pores of a rigid ceramic bead.	20 µm	> 85 mg/mL ⁴	Polypeptide and plasmid purification
	S Ceramic HyperD 20	Strong cation exchanger. Ceramic HyperD ion exchangers employ a high capacity hydrogel polymerized within the large pores of a rigid ceramic bead.	20 µm	> 85 mg/mL ⁵	Polypeptide purification

6.5 – Section 6.5

Chromatography Type	Product	Description	Particle Size (Average)	Capacity	Primary Applications
Ion Exchange (continued)					
Separation by Charge	Bulk Resin				
	Q Ceramic HyperD® F	Strong anion exchanger. Ceramic HyperD ion exchangers employ a high capacity hydrogel polymerized within the large pores of a rigid ceramic bead.	50 µm	> 85 mg/mL ⁴	Recombinant proteins, monoclonal antibodies, plasmid, vaccine purification, capture step
	S Ceramic HyperD F	Strong cation exchanger. Ceramic HyperD ion exchangers employ a high capacity hydrogel polymerized within the large pores of a rigid ceramic bead.	50 µm	> 75 mg/mL ⁵	Recombinant proteins, monoclonal antibodies, vaccine purification, capture step
	DEAE Ceramic HyperD F	Weak anion exchanger. Ceramic HyperD ion exchangers employ a high capacity hydrogel polymerized within the large pores of a rigid ceramic bead.	50 µm	> 85 mg/mL ⁴	Recombinant proteins, monoclonal antibodies, plasmid, vaccine purification, capture step
	CM Ceramic HyperD F	Weak cation exchanger. Ceramic HyperD ion exchangers employ a high capacity hydrogel polymerized within the large pores of a rigid ceramic bead.	50 µm	> 60 mg/mL ⁶	Recombinant proteins, monoclonal antibodies, vaccine purification, capture step
	Q Hyper Z	Q Hyper Z are specifically designed for high productivity expanded bed chromatography and efficient capture of biomolecules directly from crude, unclarified samples in a single pass operation.	75 µm	> 80 mg/mL ¹¹	Expanded bed and packed, bed separations

Chromatography Type	Product	Description	Particle Size (Average)	Capacity	Primary Applications
Ion Exchange (continued)					
Separation by Charge	Bulk Resin				
	CM Hyper Z	CM Hyper Z are specifically designed for high productivity expanded bed chromatography and efficient capture of biomolecules directly from crude, unclarified samples in a single pass operation.	75 µm	~ 80 mg/mL ¹¹	Expanded bed and packed, bed separations
	Membrane Filter Plates and Devices				
	Mustang® Q	Strong anion exchanger. Also available in AcroPrep® 96 filter plates 350 µL or 1 mL, and Acrodisc® syringe filters	N/A	50-60 mg/mL	Protein fractionation
	Mustang S	Strong cation exchanger. Also available in AcroPrep 96 filter plates 350 µL or 1 mL, and Acrodisc syringe filters	N/A	45-50 mg/mL	Protein fractionation
Affinity					
Separation Using Specific Ligands	Bulk Resin				
	Blue Trisacryl® M	Blue Trisacryl M is an affinity chromatographic resin used for the purification of a wide variety of enzymes and proteins such as kinases, albumin, interferons, and some coagulation factors. The basic matrix is Trisacryl GF2000, a macroporous, non-ionic resin on which Cibacron* blue is covalently immobilized.	60 µm	HSA: 10-15 mg/mL BSA: 5-7 mg/mL ¹	Albumin depletion

6.5 – Section 6.5

Chromatography Type	Product	Description	Particle Size (Average)	Capacity	Primary Applications
Affinity (continued)					
Separation Using Specific Ligands	Bulk Resin				
	IMAC HyperCel™	IMAC HyperCel uses tridentate IDA (imino-diacetic-acid) as a chelating agent. The ligand is immobilized on the HyperCel base sorbent, a stable and robust resin.	90 µm	30-60 µmol Cu ⁺⁺ /mL resin	Tagged biomolecule purification
	Protein A Ceramic HyperD® F	Protein A Ceramic HyperD F is a high capacity affinity resin prepared using a rigid proprietary ceramic bead. Recombinant Protein A is immobilized to a specially formulated hydrogel within the porous ceramic bead.	50 µm	> 30 mg/mL ²	IgG purification/depletion
	Heparin HyperD M	Heparin HyperD M composite chromatography resin is used to purify biological molecules that bind to heparin such as coagulation factors, growth factors, and lipoproteins. Heparin HyperD M is composed of a porous rigid mineral bead containing heparin bound hydrogel filled pores.	80 µm	> 25 mg/mL ³	Purification of coagulation factors, lipoproteins, growth hormones, growth factors, nucleic acid binding enzymes.
	Lysine HyperD	Lysine HyperD is used to purify biological molecules that bind to lysine such as glycoproteins. Lysine HyperD is comprised of a porous rigid mineral bead containing lysine (L-lysine) bound hydrogel filled pores.	70 µm	N/A	Purification of glycoproteins

6.5 – Section 6.5

Chromatography Type	Product	Description	Particle Size (Average)	Capacity	Primary Applications
Affinity (continued)					
Separation Using Specific Ligands	Kits				
	Enchant™ Albumin Depletion Kit	For the depletion of albumin from plasma or serum. Includes all buffer and devices needed for 25 purifications.	N/A	> 2 mg albumin per purification	Albumin depletion or isolation
	Enchant Multi-Protein Affinity Separation Kit	For the removal of 99% of albumin and IgG from serum/plasma samples.	N/A	> 99% removal	Albumin and IgG fractionation
Mixed Mode and Hydrophobic Charge Induction (HCIC)					
A Unique Combination of Chromatography Modes	Bulk Resin				
	MEP HyperCel™	MEP HyperCel (4-mercapto-ethyl-pyridine) resin is specifically designed for the capture and purification of monoclonal and polyclonal antibodies. In contrast to Protein A resins, IgG binding on MEP HyperCel is essentially independent of subclass or species. Weakly binding variants (e.g., murine IgG, rat IgG) are well retained.	90 μm	> 20 mg/mL ⁷	Purification/depletion of polyclonal and monoclonal antibodies of most species.

6.5 – Section 6.5

Chromatography Type	Product	Description	Particle Size (Average)	Capacity	Primary Applications
Mixed Mode and Hydrophobic Charge Induction (HCIC) (continued)					
A Unique Combination of Chromatography Modes	Bulk Resin				
	SDR HyperD®	SDR HyperD is a mixed mode of size exclusion, normal phase, and reversed phase. It is a unique resin designed to eliminate solvent and detergent while recovering NATIVE protein. SDR HyperD is a composite resin that combines a silica bead moiety filled with long chain aliphatic polymers that are cross-linked to provide a 3D mesh with a low size exclusion limit of 10 kDa which excludes proteins.	80 µm	60-80 mg/mL ¹³	Solvent and detergent removal
Hydroxyapatite					
Protein Interaction with Calcium Phosphate	Bulk Resin				
	HA Ultrogel®	HA Ultrogel hydroxyapatite resin is composed of cross-linked agarose beads with micro-crystals of hydroxyapatite entrapped in the agarose mesh.	120 µm	Cytochrome C: > 7 mg/mL ⁹	Immunoglobulin separation, glycoproteins, vaccines

Footnotes — Chromatography Products Selection Guide

1. Capacity determined in PBS buffer using 5 mg/mL.
2. Dynamic binding capacity, 10% breakthrough, 100 cm/h, determined using 10 mg/mL hu IgG in PBS, pH 7.4; elution in 0.1 M sodium citrate, pH 2.5; column 4.6 ID x 100 mm.
3. Dynamic binding capacity at 600 cm/h, using hu ATIII at 72.5 UI/mL in 20 mM Tris-HCl, 0.3 M NaCl, pH 7.4; elution with 20 mM Tris-HCl, 2 M NaCl, pH 7.4; 10 cm bed height.
4. Dynamic binding capacity, 10% breakthrough, 200 cm/h; sample: 5 mg/mL BSA in 50 mM Tris-HCl buffer, pH 8.6.
5. Dynamic binding capacity, 10% breakthrough, 200 cm/h; sample: 5 mg/mL lysosome in 50 mM sodium acetate, pH 4.5.
6. Dynamic binding capacity, 10% breakthrough, 200 cm/h; sample: 5 mg/mL hu IgG in 50 mM sodium acetate, 100 mM NaCl, pH 7.4.
7. Dynamic binding capacity, 10% breakthrough, determined using 5 mg/mL hu IgG in PBS, flow rate: 60 cm/h.
8. Dynamic binding capacity, 10% breakthrough, determined using 5 mg/mL hu polyclonal IgG; adsorption 50 mM sodium acetate, 0.14 M NaCl, pH 5.5; 5 min residence time.
9. Capacity for cytochrome c, determined using 5 mg/mL cytochrome c diluted 50/50 in 1 mM phosphate buffer, pH 6.8; at 12.5 cm/h.
10. Dynamic binding capacity, 10% breakthrough determined using 5 mg/mL BSA in 50 mM Tris-HCl buffer, pH 8.6; 150 mM NaCl.
11. Dynamic binding capacity, 10% breakthrough, determined using 5 mg/mL hu IgG in 50 mM sodium acetate buffer, pH 4.7; 150 mM NaCl.
12. Dynamic binding capacity, 10% breakthrough at 300 cm/h, determined using 5 mg/mL Triton* in PBS, pH 7.4.

6.6 – Section 6.6

6.6 BioSeptra Media

Figure 6.9

Base Materials for BioSeptra Media Chromatography Resins

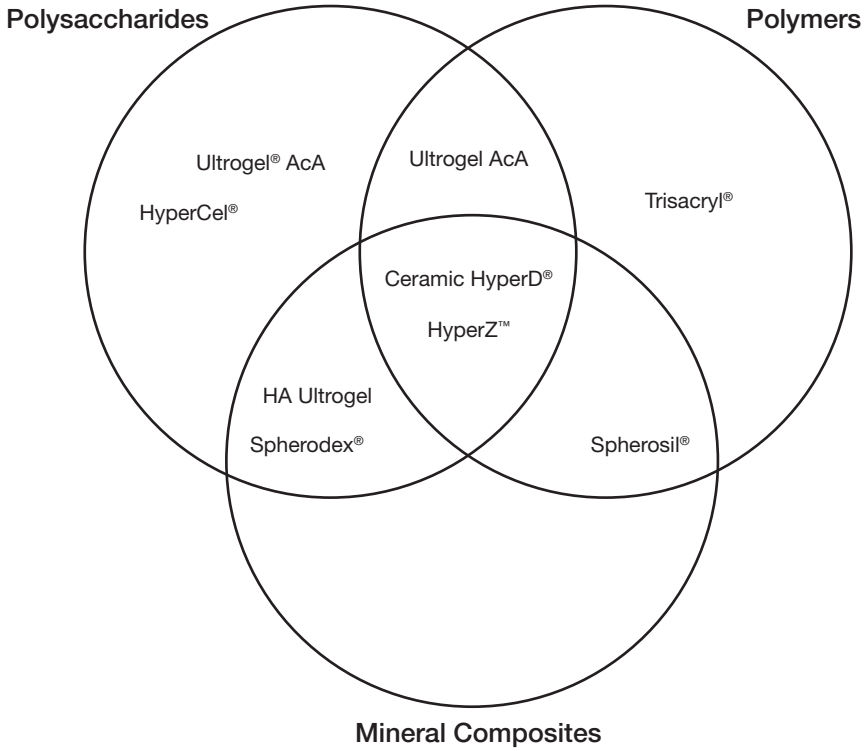

6.7 Protein Sample Preparation and Analysis Media

Protein Purification
and Analysis Media

Characteristic

Separation Technologies	Membrane Name	Medium	Surface Chemistry	Characteristic										Recommended Applications		
				Capture Release Concentrate	High Molecular Weight Binding	Low Molecular Weight Binding	Binds Leukocytes	Viral Particle Capture/Release	Hydrophobic	Hydrophilic	Compatible with Hersh Chemicals	Chromatography	Filtration		Pretreatment	
Microfiltration	Bio-Inert® Membrane	Modified Nylon	Hydroxyl													Filtration of protein solutions, low protein binding, general filtration, clarification of cell lysate and tissue homogenates
	Fluorodyne® II Membrane	PVDF	Hydroxyl													Filtration of low concentration proteins, sample preparation, general filtration
	GH Polyporo Membrane (GHP)	Polypropylene	Proprietary													Time-resolved fluorescence, bead-based assays, fluorescent detection of analytes, sample prep prior to HPLC, general filtration of aqueous and organic solvents
	HT Tuifryne® Membrane	Polysulfone	Proprietary													Proven performance in documented procedures
	LoProdyne® LP Membrane	Nylon	Hydroxyl													Filtration of low concentration proteins, sample preparation
	Paliflex® Media	Glass Fiber	Varies													Prefilters, DNA extraction
	PTFE Membrane	PTFE	PTFE													Vent filters, Chemical and molecular synthesis
	Supor® Membrane	Polyethersulfone	Proprietary													General filtration applications, low protein binding, bead-based assays
	Supor R Membrane	Polyethersulfone	Repel™ Treated													Vent filters
	Versapor® Membrane	Acrylic Copolymer on a Nonwoven Support	Proprietary													General filtration applications
Ultrafiltration	Versapor R Membrane	Acrylic Copolymer on a Nonwoven Support	Repel Treated													Vent filters
	Omega™ Membrane	Modified Polyethersulfone	Proprietary													Sample preparation, PCR cleanup, sequencing cleanup, ultrafiltration separations, nucleic acid and protein purification, concentration and fractional

6.7 – Section 6.7

**Protein Purification
and Analysis Media**

Characteristic

Separation Technologies	Membrane Name	Medium	Surface Chemistry	Characteristic										Recommended Applications		
				Capture Release	High Molecular Weight Binding	Low Protein Binding	Binds Leukocytes	Viral Particle Capture/Release	Hydrophobic	Hydrophilic	Compatible with Harsh Chemicals	Chromatography	Filtration		Pretreatment	
Chromatography	BioSeptra® Size Exclusion Resins (UltraGele®, Trisacryle®)	Varies		●												Fractionation, purification, desalting
	BioSeptra Q Ion Exchange Resins (HyperD®)	Composite Material (Ceramic)	Quaternary Amine	●												Protein concentration, protein fractionation, contaminant removal, separation based on charge
	BioSeptra S Ion Exchange Resins (HyperD)	Composite Material (ceramic)	Sulfopropyl	●												
	BioSeptra DEAE Ion Exchange Resins (HyperD)	Composite Material (ceramic)	Diethylaminoethyl	●												
	BioSeptra CM Ion Exchange Resins (HyperD)	Composite Material (Ceramic)	Carboxymethyl	●												
	BioSeptra Affinity Resins (Blue Trisacryl M, Protein A Ceramic HyperD F, Heparin HyperD M, Lysine HyperD, IMAC HyperCel™)	Varies	Varies	●												Abundant protein removal, IgG purification, glycoprotein enrichment, lipoprotein purification
	BioSeptra Solvent-Detergent Removal Resins (SDR HyperD)	Composite Material (silica)	Hydrophobic Polymer Moiety	●												Detergent removal
	BioSeptra Hydrophobic Charge Induction Chromatography Resins (MEP HyperCel)	Cellulose Polymer	4-Mercapto-ethyl-pyridine	●												Purification of poly and monoclonal antibodies of various species, enzymes and recombinant proteins
	Mustang® E Membrane	Polyethersulfone (positively-charged)	Quaternary Ammonium	●								●				Removes endotoxin from buffers, water, neutral sugar solutions, and certain biological solutions
	Mustang Q Membrane	Polyethersulfone (positively-charged)	Quaternary Amine	●								●				Strong anionic exchanger for DNA clearance, nucleic acids and negatively-charged proteins, viral particle purification/concentration
	Mustang S Membrane	Polyethersulfone (negatively-charged)	Sulfonic Acid	●								●				Strong cationic exchanger for positively-charged proteins, viral particle purification/concentration

Protein Purification
and Analysis Media

Characteristic

Separation Technologies	Membrane Name	Medium	Surface Chemistry	Characteristic										Recommended Applications			
				Capture Release	High Molecular Weight Binding	High Molecular Weight Release	Low Molecular Weight Binding	Low Molecular Weight Release	Binds Leukocytes	Viral Particle Capture/Release	Hydrophobic	Hydrophilic	Compatible with Harsh Chemicals		Chromatography	Filtration	Precipitation
Binding	Biodyne® A Membrane	Nylon 6.6 (amphiphilic)															Macroarrays, microarrays, Southern blots, northern blots, dot blots, reverse dot blots, DNA fingerprinting, colony and plaque lifts, ELISA
	Biodyne B Membrane	Nylon 6.6 (positively-charged)	Quaternary Ammonium														Macroarrays, microarrays, Southern blots, northern blots, dot blots, reverse dot blots, DNA fingerprinting, binds negatively-charged molecules
	Biodyne C Membrane	Nylon 6.6 (negatively-charged)	Carboxyl														Reverse dot blots, ELISA, binds positively-charged molecules
	Biodyne Plus Membrane	Nylon 6.6 (positively-charged)	Quaternary Ammonium														Macroarrays, microarrays, Southern blots, northern blots, dot blots, DNA fingerprinting, ELISA
	BioTrace™ NT Membrane	Nitrocellulose															Western blots, colony/plaque lifts, Southern blots, protein/nucleic acid dot blots, flow-through diagnostic tests, northern blots
	BioTrace PVDF Membrane	PVDF															Western blots, protein dot blots
	FluoroTrans® PVDF Membrane	PVDF															N-terminal protein sequencing, lowest levels of autofluorescence
	FluoroTrans W Membrane	PVDF															Western blots, Southern blots
	Immunodyne® ABC Membrane	Modified Nylon	Proprietary Activated Surface														Oligonucleotide arrays, reverse dot blots, protein arrays, immunoassays
	Leukosorb® Membrane	Proprietary	Proprietary														Leukodepletion, nucleic acid extraction, <i>in situ</i> PCR
	UltraBind™ Membrane	Modified Polymersulfone (unsupported)	Aldehyde														Affinity chromatography, ELISA, ELISPOI

CHEMICAL COMPATIBILITY GUIDE

6.8 – Section 6.8

6.8 Chemical Compatibility Guide

	Acetone	Acetonitrile	Acetic acid, glacial	n-Butanol	Chloroform (100%)	Dioxane	Dimethyl formamide (20%)	Dimethyl sulfoxide (20%)	Ethanol	Ethyl acetate	Ethyl ether	Freon TF	Hydrochloric acid (1N)	Hexane, dry	Methanol	Methylene chloride	Methyl ethyl ketone (10%)	N-Methylpyrrolidone	Isopropanol	Sodium hydroxide (3M)	Tetrahydrofuran	Tetrahydrofuran/water (50/50)	Toluene	Water
Bio-Inert® membrane	L	L	N	R	R	●	L	L	R	N	R	●	N	R	R	L	R	●	N	R	R	R	R	R
BioTrace™ NT membrane	N	N	N	N	R	●	N	N	N	N	N	●	●	R	N	N	N	●	R	●	N	●	R	R
BioTrace PVDF membrane	N	R	R	R	R	●	N	N	R	R	R	●	R	R	R	R	N	●	R	N	N	●	R	R
FluoroTrans® membrane	N	R	R	R	R	●	N	N	R	R	R	●	R	R	R	R	N	●	R	N	N	●	R	R
GH Polypro (GHP) membrane (hydrophilic polypropylene)	R	R	R	R	R	R	R	R	R	R	R	R	R	R	R	R	R	R	R	R	R	R	R	R
Glass Fiber	R	R	R	R	R	R	R	R	R	R	R	R	R	R	R	R	R	R	R	L	R	R	R	R
Nylon membrane	R*	R	N	R	R	●	R*	R*	R	R*	R	R	N	R	R	R	R*	R*	R	L	R	R	R*	R
Omega™ PES membrane	R	R	R	R	R	●	R	R	R	R	●	●	R	●	●	●	R	R	R	R	R	●	R	●
PTFE membrane within multi-well plates	L	●	N	L	R	N	N	●	R	R	N	●	R	●	L	R	L	●	L	R	R	●	L	R
Supor® PES membrane (polyethersulfone)	N	R	R	R	N	●	N	N	R	N	R	L	R	L	R	N	N	N	R	R	N	●	R	R
Versapor® membrane (acrylic copolymer)	N	N	N	R	N	N	N	N	R	N	N	R	L	N	L	N	N	N	R	R	N	●	N	R

*2 mL of solvent was filtered with UV absorbance set at 254 nm. Membrane integrity was tested by bubble point.

**Test Methods: The data presented in this chart is a compilation of testing by Pall Corporation with certain chemicals, manufacturer's data, or compatibility recommendations from the Compass Corrosion Guide, by Kenneth M. Pruett. This data is intended to provide expected results when filtration devices are exposed to chemicals under static conditions for 48 hours at 25 °C (77 °F), unless otherwise noted. This chart is intended only as a guide. Accuracy cannot be guaranteed. Users should verify chemical compatibility with a specific filter under actual use conditions. Chemical compatibility with a specific filter, under actual use conditions, is affected by many variables, including temperature, pressure, concentration, and purity. Various chemical combinations prevent complete accuracy.

NOTE:

R = RESISTANT. No significant change was observed in flow rate or bubble point of the membrane.

L = LIMITED RESISTANCE. Moderate changes in physical properties or dimension of the membrane were observed. The filter may be suitable for short term, non-critical use at room temperature.

N = NOT RESISTANT. The membrane is basically unstable. In most cases, extensive shrinkage or swelling occurs. The filter may gradually weaken or partially dissolve after extended exposure.

● = INSUFFICIENT DATA. Information not available. Trial testing is recommended.