

## Selection Guide

### Ultipleat® High Flow Filter System

#### Description

The Ultipleat® High Flow filter is a large diameter, coreless, single open ended, pleated cartridge with an inside to outside flow pattern. The filter's unique crescent-shaped pleat geometry, combined with its large 6 inch (152.4 mm) diameter and proprietary range of available Pall filter media, allows you to use significantly fewer filters and smaller housings for high flow rate applications. Systems can handle up to 30,500 gpm (115,443 lpm).

#### Benefits

- Up to 50% smaller filter system possible
- Up to 40 times fewer elements to change out
- Higher flow rates per filter cartridge - up to 500 gpm (1900 lpm)
- Available in 20 inch (508 mm), 40 inch (1016 mm), 60 inch (1524 mm) and 80 inch (2032 mm) lengths
- Coreless, all plastic construction to minimize waste disposal
- Absolute rated filter medium for reproducible performance
- Inside to outside flow configuration - all debris stay within the filter

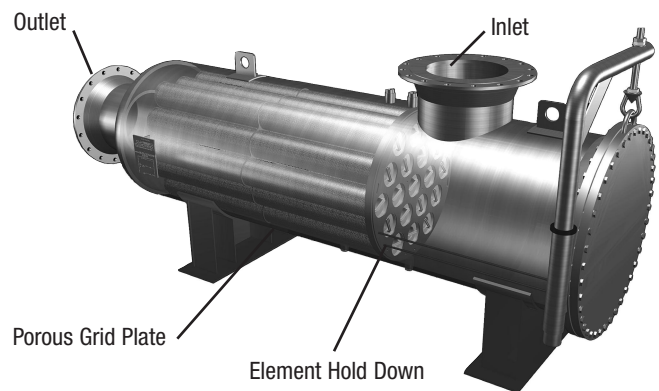
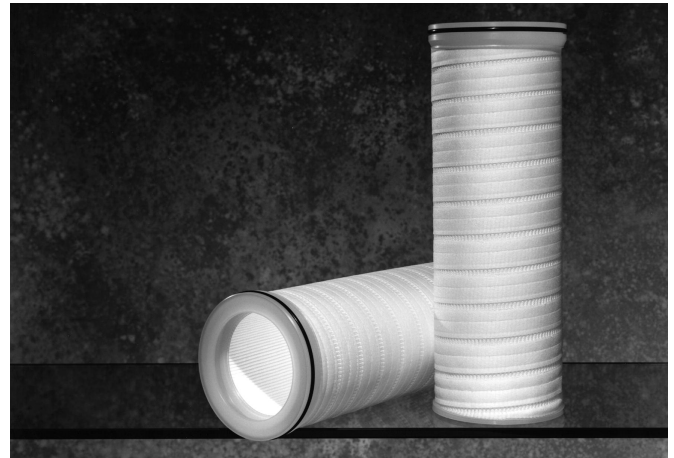

#### Materials of Construction

Filter Medium Type	Filter Medium	Support/Drainage Materials	End Caps	Wrap Materials
HDC® II Medium	High Area Polypropylene Structure	Polypropylene	Glass Filled Polypropylene	Polypropylene and Polyolefin Hotmelt
Profile® Medium in Ultipleat Format	Pleated Polypropylene Depth Structure	Polypropylene	Glass Filled Polypropylene	Polypropylene
Ultipor® GF Medium	Resin Bonded Glass Fiber / Polyester Support	Polyester / Nylon	Glass Filled Acetal	Polyester and Polyamide Hotmelt
Ultipleat CAS Medium	Pleated Polypropylene / Polyether Sulfone Membrane	Polypropylene	Glass Filled Polypropylene	Polypropylene

## Operating Conditions

	Polypropylene Medium/ CAS Composite Medium	Glass Fiber Medium <sup>2</sup>
Maximum Differential Pressure <sup>1</sup> (normal inside to outside flow)	50 psid at 180°F 3.4 bar at 82°C	50 psid at 250°F 3.4 bar at 121°C

1) For fluids compatible with the filter element at the stated temperature.

2) Maximum temperature in aqueous systems is 140°F / 60°C

## Ordering Information/Specifications

Filter Cartridge Part Number: HFU ▲ ● ◆

Code ▲	Filter Dimensions, nominal, diameter (in/mm) x length (in/mm)	Suggested Maximum Water Flow Per Cartridge (gpm/lpm/mgd)
620	6/152.4 x 20/508	175/663/0.25
640	6/152.4 x 40/1016	350/1325/0.5
660	6/152.4 x 60/1524	500/1900/0.7
680	6/152.4 x 80/2032	500/1900/0.7

## Filter Cartridge Pressure Drop (typical) per Filter Length Shown<sup>2</sup>

Medium Type	Grade ●	Absolute Liquid Removal Rating (microns) at 99.98% by particle count <sup>1</sup>	20 inch length		40 inch length		60 inch length		80 inch length	
			psid/100gpm	mbar/M <sup>3</sup> /hr	psid/100gpm	mbar/M <sup>3</sup> /hr	psid/100gpm	mbar/M <sup>3</sup> /hr	psid/100gpm	mbar/M <sup>3</sup> /hr
HDC II Medium	J060	6	0.158	0.48	0.080	0.24	0.058	0.17	0.040	0.012
	J100	10	0.120	0.36	0.060	0.18	0.040	0.12	0.030	0.009
	J200	20	0.100	0.30	0.050	0.15	0.033	0.10	0.025	0.008
Profile Medium in Ultipleat Format	UY020 <sup>4</sup>	2	1.091	3.31	0.540	1.64	0.362	1.10	0.270	0.082
	UY045	4.5	0.489	1.48	0.242	0.73	0.162	0.49	0.121	0.037
	UY060	6	0.395	1.20	0.196	0.59	0.131	0.40	0.098	0.030
	UY100	10	0.344	1.04	0.170	0.52	0.114	0.35	0.085	0.026
	UY200	20	0.243	0.74	0.120	0.36	0.080	0.24	0.060	0.018
	UY400 <sup>3</sup>	40	0.182	0.55	0.090	0.27	0.060	0.18	0.045	0.014
	UY700 <sup>3</sup>	70	0.040	0.12	0.020	0.06	0.013	0.04	0.010	0.003
UY1000 <sup>3</sup>	90	0.027	0.08	0.013	0.04	0.009	0.03	0.007	0.002	
Ultipor GF Medium	GF020	2	0.219	0.66	0.110	0.33	0.073	0.22	0.055	0.017
	GF060	6	0.180	0.55	0.090	0.27	0.060	0.18	0.045	0.014
	GF100	10	0.159	0.48	0.080	0.24	0.053	0.16	0.040	0.012
	GF200	20	0.119	0.36	0.060	0.18	0.040	0.12	0.030	0.009
	GF400 <sup>3</sup>	29	0.100	0.30	0.050	0.15	0.033	0.10	0.025	0.008
Ultipleat CAS Medium	CAS010	1	1.496	4.54	0.740	2.25	0.496	1.51	0.370	1.12

1) The test procedure used is an adaptation of ISO 4572, modified to determine the micron size above which particles are quantitatively removed.

2) Multiply this value by the total system flow to determine the aqueous pressure drop. For fluids other than water, multiply this value by the fluid's viscosity at the operating temperature in centipoise. This value is the pressure drop across the Ultipleat® High Flow filter(s) only; it must be added to the pressure drop contribution from the Ultipleat High Flow filter housing.

3) Precision evaluation of the 99.98% removal efficiency for these coarse grades is not possible with the ISO modified test procedure utilized. The removal efficiency was determined by the maximum spherical particle analysis.

4) 2 micron at 99% efficiency

Code-Filter O-Ring ◆	Material
H13 (Standard for glass fiber and aramid fiber filters)	Buna N
H13U <sup>1</sup>	Buna N U-Cup
J (Standard for polypropylene filters)	Ethylene Propylene
JU <sup>1</sup>	Ethylene Propylene U-Cup
H4	Silicone
H	Fluoroelastomer

<sup>1</sup> U-Cup seal is standard for the 1 micron composite filter.

## Housing Design

Three configurations are available: horizontal\*, vertical and centerpipe design.

The in-line horizontal configuration eliminates the need for a platform, or ladder, to remove the filters from the housing.

Vertical vessels may be more appropriate when floor space is limited. However, a platform may be needed to easily remove the elements.

\* Required for 80 inch lengths

In both the standard horizontal and vertical configurations, the inlet pipe is located between the filter element tubesheet and housing lid. The larger the vessel diameter, the longer the distance to reach in and remove the elements from the vessel. In a centerpipe vessel the housing lid is closer to the filter tubesheet. When the lid is opened the filters are easily accessible for installation and removal. Centerpipe vessels are larger in diameter, and more costly.

- Designed to the ASME, section VIII, division 1 code

- Maximum differential pressure across tubesheet: 75 psid (5.17 bar) maximum
- Standard housing gasket: spiral wound 304 stainless steel mineral fiber
- Carbon steel exterior surfaces: sandblasted and coated with an inorganic zinc
- Vent and drains: 1 inch FNPT
- Corrosion allowance: 1/8 inch

### Housing Ratings

Vessel Material	Tubesheet and Hold Down Plate Material of Construction	Pressure Rating in Psig/Bar g at 140°F / 60°C
Carbon steel	304 stainless steel	275 psig (18.95 bar)
304 stainless steel	304 stainless steel	259 psig (17.85 bar)
304L stainless steel	304L stainless steel	216 psig (14.89 bar)
316 stainless steel	316 stainless steel	261 psig (17.99 bar)
316L stainless steel	316L stainless steel	216 psig (14.89 bar)

### Filter Installation and Filter Seal Mechanism

To install a filter element, remove the element hold down plate by lifting it off the locating pins. Lubricate the O-ring on the open-end of the filter with a compatible fluid, and slide the closed end of the filter into the perforated cage, which is welded to the tubesheet. Seat the elements in place by pressing down on the open-end of the filter until the element is snug in the tubesheet. This provides a seal between the filter and housing via the filter O-ring. The open-end cap must be below the tubesheet surface. After

installing all the filter cartridges, reinstall and secure the element hold down plate by guiding it over the locating pins on the tubesheet. The purpose of the hold down plate is to prevent the elements from becoming dislodged in the event of reverse flow.

A filter element tool is provided with each housing to aid with the installation and removal of the filter cartridges. This tool eliminates the need for an operator to reach within the filter vessel to either remove or install filters.

**Figure 1: Ultipleat High Flow Horizontal Housings (Aqueous Housing Pressure Drop - PSID)**

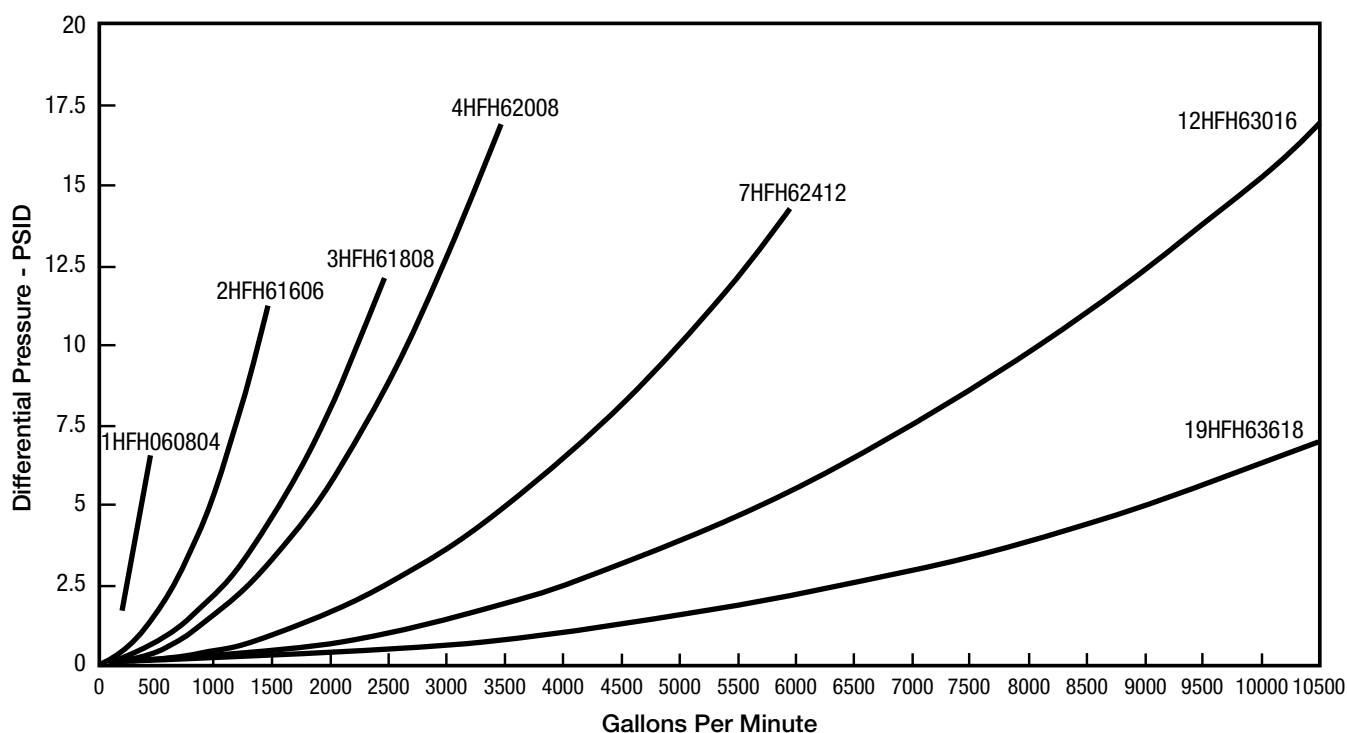

## Ordering Information-Standard Horizontal and Vertical Housings

Part Number	No. Of Filters	Rated Flow Per Housing- GPM/LPM 60" Long Filter	Nominal Housing Diameter (in/mm) (D)	Inlet/Outlet Flange Diameter (in/mm)	Maximum* Horizontal Housing Overall Length (in/mm) (L)	Horizontal Housing Height (in/mm) (H)	Distance Between Housing and Lid and Tubesheet (in/mm)	Housing* Weight Empty (lbs/kg)	Housing* Weight Full Of Water (lbs/kg)	Housing Cover Swing Opening (in/mm)
1HF ■ ● 0804F1 ▲ ◆	1	500/1893	9/219.1	4/101.6	89/2261	32/817	14.5/368.3	471/214	621/282	9.0/228.6
2HF ■ ● 1606F1 ▲ ◆	2	1000/3785	16/406.4	6/152.4	100/2527	40/1023	22.7/576.3	1172/532	1771/803	25.8/654.6
3HF ■ ● 1808F1 ▲ ◆	3	1500/5680	18/457.2	8/203.2	104/2642	43/1093	26.2/665.2	1583/718	2384/1081	27.3/692.8
4HF ■ ● 2008F1 ▲ ◆	4	2000/7570	20/508.0	8/203.2	105/2654	46/1175	26.4/669.6	2087/947	3048/1382	29.8/756.3
7HF ■ ● 2412F1 ▲ ◆	7	3500/13248	24/609.6	12/304.8	112/2832	59/1487	31.9/809.6	3250/1474	4762/2160	34.3/870.6
12HF ■ ● 3016F1 ▲ ◆	12	6000/22710	30/762.0	16/406.4	121/3073	58/1480	38.7/982.7	4670/2118	7306/3314	38.0/964.9
19HF ■ ● 3620F1 ▲ ◆	19	9500/35958	36/914.4	20/508.0	129/3264	68/1718	43.4/1101.6	7060/3202	11121/5045	44.8/1138.8

\* For 60 inch filter lengths

## Ordering Information - Horizontal Orientation, Centerpipe Designed Housings

Part Number	No. Of Filters	Rated Flow Per Housing- GPM/LPM 60 in Long Filter	Nominal Housing Diameter (in/mm) (D)	Inlet/Outlet Flange Diameter (in/mm)	Maximum* Horizontal Housing Overall Length (in/mm) (L)	Horizontal Housing Height (in/mm) (H)	Distance Between Housing and Lid and Tubesheet (in/mm)	Housing* Weight Empty (lbs/kg)	Housing* Weight Full Of Water (lbs/kg)	Housing Cover Swing Opening (in/mm)
7HF ■ C ● 2808F1 ▲ ◆	7	3500/13248	28/711	8/203.2	104.3/2648	57.0/1448	4.9/124	4056/1840	6229/2825	36/914
8HF ■ C ● 3012F1 ▲ ◆	8	4000/15140	30/762	12/304.0	117.6/2988	58.3/1480	6.1/154	4707/2135	7348/3333	40/1018

\* For 60 inch filter lengths

Code	Housing Configuration
■	
H	Horizontal
V	Vertical

Code	Housing Metallurgy
▲	
285	Carbon Steel Vessel, 304 Stainless Steel Tubesheet
S3	304L Stainless Steel
S8	304 Stainless Steel
L3	316L Stainless Steel
L8	316 Stainless Steel

Code	Nominal Cartridge Length (in/mm)
●	
2	20/508
4	40/1016
6	60/1524
8	80/3032

Code	Optional Outlet Size <sup>1</sup> Horizontal Housings
◆	
XU	Upper Outlet Location
XL	Lower Outlet Location

<sup>1</sup> If the housing is to be used as a prefilter to a horizontal liquid/liquid coalescer, then the vessel should be ordered using the XU or XL option for the outlet location. The orientation of the outlet should be the same as that of the sump on the coalescer. In this way no buildup of coalesced liquid will occur in the prefilter.

## Horizontal Housings

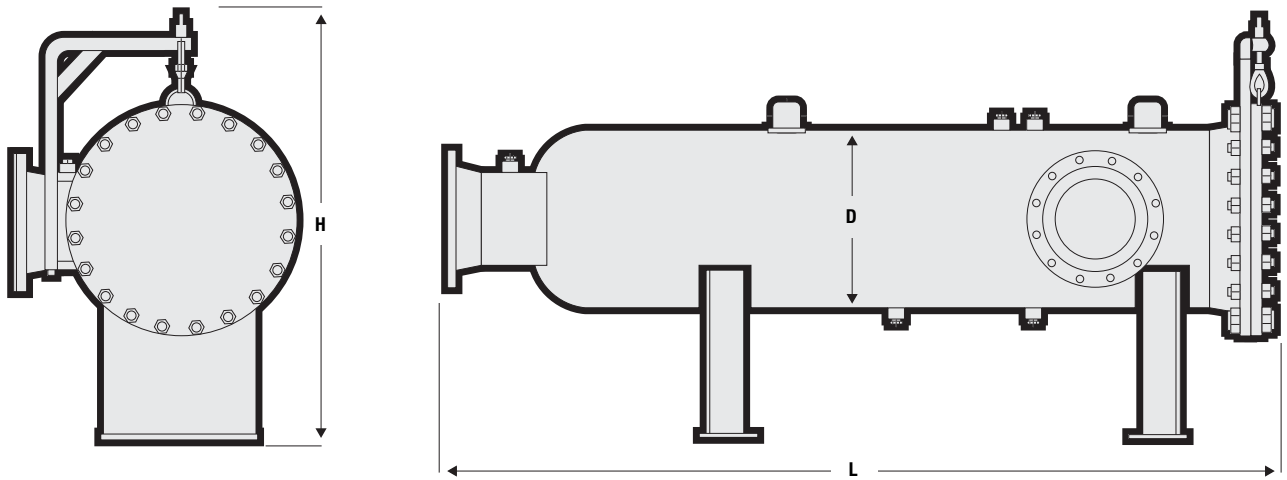

## Horizontal Housings, Centerpipe Design

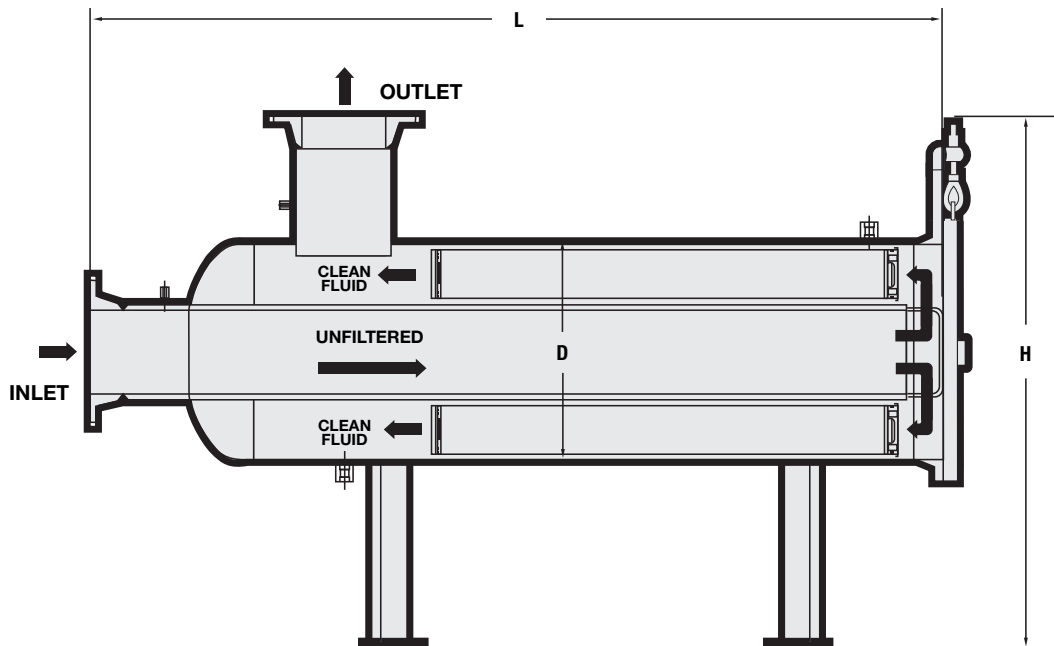

## Ultipleat High Flow Filter System Reduces Costs

Begin reducing your capital and operating costs today. Contact your local Pall distributor, or call Pall directly for an Ultipleat High Flow system quotation.



**Pall Corporation**

**Corporate Headquarters**

25 Harbor Park Drive  
Port Washington, NY 11050  
888.873.7255 toll free  
516.484.3600 phone  
516.801.9762 fax  
fuelsandchemicals@pall.com

**United Kingdom**

Europa House, Havant Street  
Portsmouth PO1 3PD  
Hampshire, England  
+44 (0) 23 9230 2357 phone  
+44 (0) 23 9230 2509 fax

*Filtration. Separation. Solution.<sup>SM</sup>*

**Visit us on the Web at [www.pall.com](http://www.pall.com)**

Pall Corporation has offices and plants throughout the world. For Pall representatives in your area, please go to [www.pall.com/contact](http://www.pall.com/contact).

Because of technological developments related to the products, systems, and/or services described herein, the data and procedures are subject to change without notice. Please consult your Pall representative or visit [www.pall.com](http://www.pall.com) to verify that this information remains valid. Products in this document may be covered by one or more of the following patent numbers: EP 667,800; EP 982,061; EP 1,380,331; US 5,543,047; US 5,690,765; US 5,725,784; US 6,113,784; US 7,083,564; US 7,318,800; EP 813,623; US 5,690,873; US 6,110,589; US 6,130,292; EP 470,485; US 5,252,207; US 5,552,048.

© Copyright 1999, 2009 Pall Corporation. Pall, , Ultipleat, Profile, HDC, and Ultipor are trademarks of Pall Corporation.

® Indicates a trademark registered in the USA. *Filtration. Separation. Solution.<sup>SM</sup>* is a service mark of Pall Corporation.

GDS 131b

December 2009