

New: Retrofit for Dollinger LG Coalescer

Introducing Pall's LG coalescer technology for 'direct replacement' of Dollinger LG coalescers to protect equipment including compressors and turbines, amine sweetening, desiccant and catalyst beds

Pall's retrofit products allow users of other manufacturers' elements to benefit from Pall technology without the need to replace the existing housing/vessel. Pall retrofit products are direct replacements for existing elements, offering the performance and value you have come to expect from Pall.

Advantages of Pall Technology

Pall's filter media and element designs bring together industry leading technologies and advanced manufacturing processes to deliver unsurpassed performance and value (e.g. long service life and reduced amine loop foaming) in each and every element.

Pall Retrofit p/n:

RDLLG430GFV

Replaces: Dollinger p/n: 79-1906

RDLLG424GFV

Replaces: Dollinger p/n: 79-1198

Specifications

- Efficiency = 1 ppbw by modified CAGI-400
- Capture Efficiency = 99.96% at 0.3 micron
- Max Temp = 180°F (82.2°C) with no water
= 140°F (60°C) with water present
- Element Burst > 30 psid (2.07 bar)
- Element Weight = 4.5 lbs (2.04 kg)
- **Materials of Construction**
Medium: glass fiber
End Caps: stainless steel
Core and Outer Cage: tin plated carbon steel
- Full element surface treatment for rapid liquids drainage

Global Presence – Local Support

Pall is a global company with offices in Asia, Americas, Europe, and the Middle East. This global presence gives us the ability to provide local commercial or technical support whenever or wherever there is a customer need.

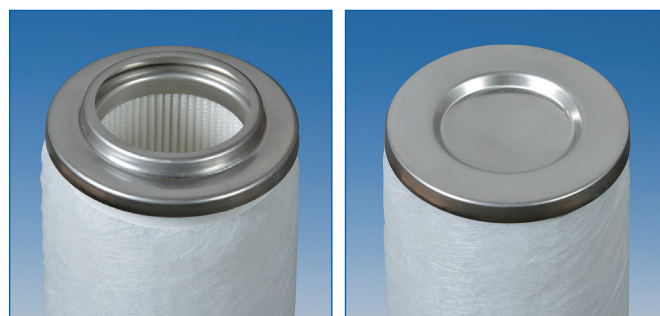

Nominal Element Dimensions

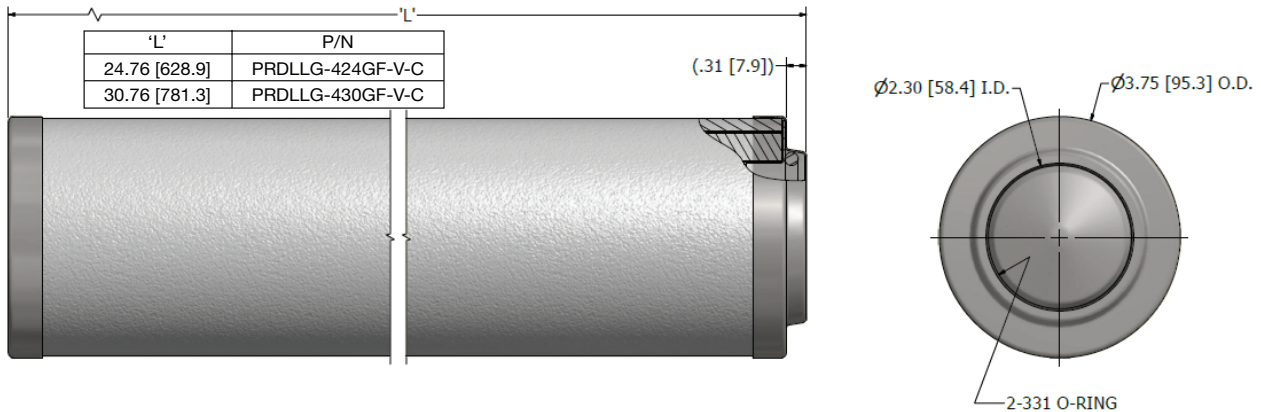

Quality Note

Pall-Fit coalescers are manufactured at Pall sites that are ISO9001 certified. They are traceable back to manufacturing lots by date code printed on the bag label.



25 Harbor Park Drive
 Port Washington NY 11050
 +1 516 484 3600 telephone
 +1 800 289 7255 toll free US

Portsmouth - UK
 +44 (0)23 9233 8000 telephone
 +44 (0)23 9233 8811 fax

www.pall.com/contact

Filtration. Separation. Solution.SM



Visit us on the Web at www.pall.com

Pall Corporation has offices and plants throughout the world. For Pall representatives in your area, please go to www.pall.com/contact

Because of technological developments related to the products, systems, and/or services described herein, the data and procedures are subject to change without notice. Please consult your Pall representative or visit www.pall.com to verify that this information remains valid.

© Copyright 2018, Pall Corporation. Pall and  are trademarks of Pall Corporation. ® Indicates a trademark registered in the USA. Better Lives. Better Planet and *Filtration*. *Separation*. *Solution*.SM are service marks of Pall Corporation. Dollinger is a trademark of SPX FLOW TECHNOLOGY USA, INC.

PIDOLLGEN

Produced in the USA



September 2018