



**OPERATION AND MAINTENANCE MANUAL WITH ILLUSTRATED PARTS LIST  
PORTABLE FLUID PURIFIER  
PART NUMBER**

**PAC PN: PE-01078-[GG]-[G]-[GG]-[GG]**

**Prepared By:**

**Pall Aeropower Corporation (PAC)  
10540 Ridge Road  
New Port Richey, FL 34654-5198  
CAGE Code: 18350**

**Document Number: PLM-TM-97059  
Document Revision: D  
Original Issue Date: November 16, 2012  
Revision Date: April 25, 2013**

**APPROVAL & CONCURRENCE:**

The undersigned attest that this a true report of Operation And Maintenance Manual With Illustrated Parts List for the Portable Fluid Purifier PAC PN: PE-01078. Electronic signatures shall be recognized as equivalent to written signatures for the purpose of approval, certification, comment, and data submission.

<b>Technical Writer:</b>	<u>s/ G. Adams</u> G. Adams 04/25/13	<b>Principal Engineering Manager:</b>	<u>s/ A. Patel</u> A. Patel 04/25/13
<b>Manufacturing Engineer:</b>	<u>s/ V. Kennedy</u> V. Kennedy 04/25/13	<b>Configuration Control Leader:</b>	<u>s/ L. Leiser</u> L. Leiser 04/25/13

**PALL AEROPOWER CORPORATION PROPRIETARY INFORMATION**

This document, or its embodiment in any media: (1) discloses information proprietary to Pall Aeropower Corporation, (2) is an unpublished work protected under applicable copyright laws, and (3) is delivered on the express condition that it is not to be disclosed, reproduced (in whole or in part including reproduction as a derivative work), or used for manufacture by anyone other than Pall Aeropower Corporation without its written consent. No right is granted to disclose or so use any information contained herein. All rights reserved. Any act in violation of applicable law may result in civil and criminal penalties.

These commodities, technology or software may only be exported from the United States in accordance with the Export Administration Regulations. Diversion contrary to U.S. law is prohibited

Record of Revisions

REV	DESCRIPTION/CHANGE	RELEASED BY	DATE RELEASED
A	Revised/Reformatted		12/07/1998
B	Revised Parts List/Figure 6-10	Y. Cheng/J. Rigby/ A.Patel	01/26/2000
C	Per ECO 305-10-004	L. Duck/A. Patel	05/24/2010
D	Revised/Reformatted to Word	G. Adams/A. Patel	04/25/2013

Keep this record in the front of the manual. Put revised pages into the manual. Enter the revision number, the date, and your initials.

**IMPORTANT ENGINEERING ADVISORY**

**ELECTRICAL REQUIREMENTS FOR 120 VOLT PORTABLE FLUID PURIFIER  
MODEL NUMBERS**

**PE-01078-[GG]-[G]-[GG]-[GG]**

**A. BASIC ELECTRICAL REQUIREMENTS:**

Voltage: 115 VAC allowable range 126/109 Volts; 60 Hz; Single Phase (grounded). Full Load Amps: 15 Amps maximum. Electrical Receptacle and all circuit components must be sized for 15 Amps (minimum) service. Supply wire must be large enough to provide required voltage at the unit during startup. NEVER use #14 AWG or smaller wire! #12 AWG is the ABSOLUTE MINIMUM. #10 AWG is a better choice for many applications where the length of run is not excessive. Refer to the Table A-1 for recommended supply wire gauges for various lengths (one way) of supply wire.

TABLE A-1

SUPPLY WIRE SIZE	LENGTH (1 Way)
#12 AWG	UP TO 15'
#10 AWG	15' TO 30'
# 8 AWG	30' TO 45'
#6 AWG	45' TO 70'

**B. ELECTRICAL PLUG/RECEPTACLE:**

- 1) The purifier plug conforms to NEMA 5-15P, the mating receptacle conforms to NEMA-5-15R. Pall Corporation receptacle #AA-9500-2584. Hubbel receptacle part number: 5266C.
- 2) This receptacle accepts standard 15 Amp 3 prong plug.
- 3) All wiring must comply with applicable national and local codes.

### Part Number Nomenclature

PE01078-[GG]<sup>1</sup>-[G]<sup>2</sup>-[GG]<sup>3</sup>-[GG]<sup>4</sup>

Code [GG] <sup>1</sup>	Supply Voltage
12	120V/60Hz
20	208V/60Hz
23	230V/60Hz
48	460V/60Hz
57	575V/60Hz
11	110V/50Hz
22	220V/50Hz
38	380V/50Hz
44	440V/50Hz
40	120V/50,60 or 400 Hz
24	240V/50, 60Hz or 120V/50,60 or 400 Hz

Code [G] <sup>2</sup>	Seal Option
H	Buna-N
Z	Viton
J	EPR

Code [GG] <sup>3</sup>	Special Options/Accessories
Omit	None
B	Boost Pump with (2) 30' Hoses, (1) 15' hose, and 50' Boost Pump Power Cable
C	Boost Pump with (2) 50' Hoses, (1) 25' hose, and 75' Boost Pump Power Cable
D	Boost Pump with (2) 100' Hoses, (1) 25' hose, and 150' Boost Pump Power Cable
F	Forklift Tines
H	Re-Nameplated for High Altitude (5300 ASL)
L	Liquid Filled Pressure & Vacuum Gauges
O	Recirculation Loop
P	Fill Port on Upper Vacuum Chamber
R	Inlet Pressure Regulator
S	Outlet Sampling Valve
T	Tiedown Eyes
W	Water Sensor
X	Explosion Proof (Class 1, Group D, Division 2)
WW	includes FORWS options
ZZ	includes BHWS options
YY	includes PSFTL options
Y	Reservoir Assy
E	Heat Exchanger

Code [GG] <sup>4</sup>	Test Fluid
Omit	Not Specified
11	MOBIL-DTE 11
13	MOBIL-DTE 13
16	MIL-DTL-17111
17	MIL-PRF-17331
18	FRYQUEL EHC
19	MIL-H-19457
20	MIL-C-47220
23	MIL-L-23699
24	MOBIL-DTE 24
25	MOBIL-DTE 25
30	MIL-H-24430
40	FC-40 (3M Flourinert)
46	MIL-H-48170
47	*COOLANOL 20
48	*COOLANOL 25
50	*SKYDROL 500
51	*SKYDROL LD-4
52	**HYJET IV
53	MIL-H-53119
56	MIL-H-5606
57	MIL-H-87257
60	UNIVOLT 60
68	MIL-H-6083
72	MIL-L-17672
78	MIL-L-7808
80	Turbo Oil 2380
83	MIL-H-83282
87	MIL-PRF-87252 (PAO)
90	2190-TEP

### Recommended Seal Option by Fluid Application

Code H	Code Z	Code J
-MIL-PRF-87252	-MIL-C-47220	-MIL-H-19457
-MIL-H-5606	-MIL-H-53119	-Type VI&V Phosphate Esters
-MIL-H-6083	-MIL-L-7808	**Hyjet
-MIL-H-24430	-MIL-L23699	*-Skydrol LD-4
-MIL-H-46170	-Turbo Oil 2380	*-Skydrol 5008-4
-MIL-H-83282	*-Coolanol	-Organic Esters
-Petroleum Base	-Specified Synthetics	-Numerous Others
-MIL-DTL-17111	-Numerous Others	
-MIL-PRF-17331		
-MIL-L-17672		
-2190-TEP		
-PAO Coolants		
-Numerous Others		

\*Coolanol and Skydrol are registered trademarks of Monsanto Corporation.  
\*\*Hyjet is a registered trademark of Exxon Corporation

TABLE OF CONTENTS

<u>SUBJECT</u>	<u>PAGE</u>
TITLE.....	2
RECORD OF REVISION .....	2
IMPORTANT ENGINEERING ADVISORY .....	3
PART NUMBER NOMENCLATURE.....	4
TABLE OF CONTENTS .....	5
<b><u>SECTION 1</u></b>	
1.0 GENERAL INFORMATION.....	8
1.1 Principles of Operation.....	8
1.1.1 Purifier Flow .....	8
1.1.2 Electrical.....	9
1.2 Specifications.....	9
1.2.1 Process Fluid Type .....	9
1.2.2 Seal Compatibility: .....	9
1.2.3 Inlet Fluid Temperature .....	10
1.2.4 Inlet Pressure .....	10
1.2.5 Fluid Circulation Rate.....	10
1.2.6 Operating Viscosity .....	10
1.2.7 Operating Vacuum (Vacuum Chamber).....	10
1.2.8 Inlet Y-Strainer Filtration .....	10
1.2.9 Discharge Filter Element Rating .....	10
1.2.10 Electrical Power Requirements.....	10
1.2.11 Hose Connections:.....	10
1.2.11.1 Inlet .....	10
1.2.11.2 Outlet.....	10
<b><u>SECTION 2</u></b>	
2.0 OPERATING INSTRUCTIONS.....	15
2.1 Controls and Indicators .....	16
2.2 Purifier Setup .....	17
2.3 Purifier Startup .....	17
2.4 Shutdown .....	18
<b><u>SECTION 3</u></b>	
3.0 MAINTENANCE .....	19
3.1 Recommended Spares .....	19
3.2 Routine Maintenance .....	19
3.2.1 Drain Coalescer Sump/Bumper .....	19
3.2.2 Check Vacuum Pump Oiler.....	19
3.2.3 Check Oiler Drip Rate .....	19
3.2.4 Change Discharge Filter Element .....	19
3.2.5 Replace Coalescing Filter Element.....	20
3.2.6 Check Inlet Y Strainer .....	20
3.2.7 Replace Air Breather Element .....	20
3.3 Long Term Maintenance .....	21
3.3.1 Inspect Drive Belt .....	21
3.3.2 Inspect Power Cables .....	21
3.3.3 Check Indicating Lights .....	21

TABLE OF CONTENTS—CONTINUED

<b><u>SUBJECT</u></b>	<b><u>PAGE</u></b>
3.3.4 Inspect Hoses .....	21
3.4 Flushing Procedures .....	21
3.5 Drain Procedures .....	22
3.6 Vacuum Pump Purge Procedures .....	22
 <b><u>SECTION 4</u></b>	
4.0 TROUBLESHOOTING .....	22
4.1 Troubleshooting Guide .....	22
 <b><u>SECTION 5</u></b>	
5.0 OVERHAUL AND REPAIR .....	33
5.1 General Information .....	33
5.2 Removal and Replacement of Upper Vacuum Chamber, V-Band Clamp, O-Ring, Vacuum, Seal Retainer and Feed Tube/Tube Fitting Assembly .....	34
5.2.1 Upper Vacuum Chamber and V-Band Replacement .....	34
5.2.2 Feed Tube and Tube Fitting Replacement .....	35
5.3 Replacement of Spinning Disc, Motor Sealing Washers, Mechanical Seal/Seal Plate Assembly, O-Ring, and Disc Drive Motor. ....	36
5.3.1 Disc Replacement .....	36
5.3.2 Sealing Washer Replacement .....	37
5.3.3 Mechanical Seal/Seal Plate Assembly Replacement .....	38
5.3.4 Disc Drive Motor Replacement .....	39
5.4 Removal and Replacement of Float Valve Assembly and Float Ball .....	40
5.4.1 Float Ball and Float Valve Replacement .....	40
5.5 Replacement of Discharge Filter Assembly and Coalescing Filter Assembly .....	41
5.5.1 Discharge Filter Head Assembly (entire head assembly) Replacement. ....	41
5.5.2 Coalescing Filter Assembly Replacement .....	41
5.6 Removal and Replacement of Vacuum Pump, Discharge Pump, Main Drive Motor, Coalescer Pressure Switch, V-Belt, Sheaves, and Coupling .....	42
5.6.1 Vacuum Pump Replacement .....	42
5.6.2 Discharge Pump Replacement .....	43
5.6.3 Main Drive Motor Replacement .....	43
5.6.4 Coalescer Pressure Switch Replacement .....	44
5.6.5 V-Belt Replacement .....	44
5.6.6 Discharge Pump Sheave Replacement .....	45
5.6.7 Motor Sheave Replacement .....	45
5.6.8 Coupling Replacement .....	46
 <b><u>SECTION 6</u></b>	
6.0 ILLUSTRATED PARTS LIST .....	47
6.1 Introduction .....	47
6.2 Explanation of Columns Used in the Parts List .....	47
6.2.1 Figure and item Number Column .....	47
6.2.2 Part Number Column .....	47
6.2.3 Description Column .....	47
6.2.4 Quantity Column .....	47
6.3 Seal Compatibility .....	47

## 1.0 GENERAL INFORMATION

The Portable Fluid Purifier (hereafter referred to as the purifier) is a compact, self-contained purification system designed to remove water, air, chlorinated solvents, and solid contaminants from lubricating, hydraulic, and heat transfer fluids. The purifier employs the use of mass transfer to effect efficient removal of fluid contaminants without need for heaters or high vacuum. The unit is a mobile, wheel mounted design requiring only minimal operating area close to the contaminated fluid reservoir and ready access to the required electrical operating power.

### 1.1 Principles of Operation.

#### 1.1.1 Purifier Flow. (Refer to the flow schematic, Figure 1.1.1)

Contaminated fluid is drawn into the purifier by chamber vacuum through an inlet ball valve (BV1) and a mesh strainer (FL1). Chamber vacuum is produced via a vacuum pump (P2) driven by the main drive motor (M1). An inlet temperature gauge (G4) and inlet pressure gauge (G1) monitor inlet fluid flow respectively.

Oil leaving the float valve (FLV) enters the vacuum chamber (VC) where it is fed to the center of a spinning disc (SD) driven by the disc motor (M2). As oil expands across the surface of the spinning disc, its relative film thickness decreases until it reaches the disc edge where it is thrown off by centrifugal force. This produces very small droplets resulting in a large surface area of oil per unit volume.

Water, air and chlorinated solvents are removed by exposing the contaminated droplets of oil to an upward flow of air at low relative humidity. This low relative humidity is obtained by maintaining the vacuum chamber at 24 in. Hg via the vacuum pump. Ambient air drawn into the chamber through the inlet air filter (FL4) and air bleed orifice (OR) expands to approximately 5 times its former volume, resulting in an 80% reduction in relative humidity (RH). Thus, atmospheric air at 100% RH becomes 20% RH in the vacuum chamber and air at 60% RH becomes 12% RH. It then becomes possible, even under the most adverse atmospheric condition of 100% RH to reduce the dissolved water content of oil (in the case of oil with a water saturation value of 100 ppm) to 20% or 20 ppm. The moisture-laden air is then removed from the chamber by the vacuum pump.

The 24 in. Hg vacuum, as indicated on the chamber vacuum gauge (G2), allows volatile chlorinated solvents to “boil off” and be carried from the chamber with the exhaust air flowing from the vacuum pump to the coalescing filter assembly (FL3). Liquids removed by the coalescing filter assembly flow by gravity into the coalescer sump/bumper (CS).

If the coalescing filter element becomes clogged, a pressure switch (S2) will shut down the unit and light the red CHANGE OR DRAIN COALESCER lamp on the control box assembly. With this visual indication available, the unit cannot be operated in the automatic mode until the coalescing filter element is changed and/or the coalescer sump is emptied.

Treated oil collected at the bottom of the vacuum chamber is removed by the discharge pump (P1) at the same rate (3 gpm) of entry allowed by the float valve (FLV). Outlet fluid pressure is monitored by the outlet pressure gauge (G3). The treated oil then passes through the discharge filter assembly (FL2), through a check valve (CV), and is discharged from the purifier via the outlet ball valve (BV2).

A differential pressure switch (S3) is used to monitor status of the discharge filter assembly. If the discharge filter element reaches a terminal differential pressure (indicating pump bypass) the pressure switch closes to light the red CHANGE DISCHARGE FILTER lamp on the control box assembly but without a shutdown.

1.1.2 Electrical (see Figures 1.1.2.1, 1.1.2.2a or 1.1.2.2b)

Power application to the purifier is enabled through two (2) circuit breakers (CB1, CB2) and the main disconnect switch mounted on the control box assembly. With circuit breakers and switch closed and correct power applied, all lamps on main control box assembly will lit for (5) seconds for lamps verification and then will turn off except the yellow POWER ON lamp (1LT) on top of the control box assembly stays lit. With START switch (2PB) depressed, the main drive motor (MTR1) starts (driving the vacuum and discharge pumps). With the vacuum pump operating, process fluid is drawn into the vacuum chamber. As fluid level inside the vacuum chamber rises, the low level switch (1LLS) closes and initiates a time delay which, after approximately 5 seconds, starts the disc motor (MTR2) and unit run lamp (4LT). During normal operation of the unit, all lamps can be checked by pressing Start switch (2PB) energized.

A pressure switch (1PS) monitors status of the coalescer filter element. When sensed pressure exceeds a predetermined value, valve switch (1PS) actuates to shut down the unit and light the CHANGE OR DRAIN COALESCER lamp (3LT) on the control box assembly. Reset is accomplished by changing the coalescer filter element and/or by draining the coalescer drain sump, then restarting.

At the purifier outlet (discharge) side, pressure switch (1DPS) monitors status of the discharge filter element. If sensed pressure exceeds a predetermined differential pressure, switch actuates to light the CHANGE DISCHARGE FILTER lamp (2LT) on the control box assembly without initiating a shutdown. Indicator reset is accomplished by manually shutting down the purifier and changing the discharge filter element.

Figure 1.1.2.1 represent 120 Volt units, Figure 1.1.2.2a represent 230, 460 and 575 Volt Units (built before 01/01/2013) and Figure 1.1.2.2b represent 230, 460 and 575 Volt Units (built after 01/01/2013).

**1.2 Specifications.**

1.2.1 Process Fluid Type

Hydraulic, lubricating, or heat transfer fluid having a minimum flashpoint of 200°F (93.3°C) per ASTM D92 or 180°F (82.2°C) per ASTM D93.

1.2.2 Seal Compatibility:

**TABLE 1.2.1**

<b>SEAL CODE [G]<sup>2</sup></b>	<b>SEAL MATERIAL</b>	<b>FLUID SERVICED</b>
<b>H</b>	<b>Buna N (Nitrile)</b>	<b>Petroleum</b>
<b>Z</b>	<b>Viton (Fluorocarbon)</b>	<b>Petroleum, Specified Synthetics</b>
<b>J</b>	<b>EPR</b>	<b>Type IV Phosphate Esters (Skydrol 500)</b>



- 1.2.3 Inlet Fluid Temperature  
Maximum: +145°F (62°C)
- 1.2.4 Inlet Pressure  
Maximum: +20 PSIG  
Minimum: -10 inches Hg
- 1.2.5 Fluid Circulation Rate  
Maximum: 3 Gal/min (11.35 L/min)
- 1.2.6 Operating Viscosity  
Maximum: 1300 SSU
- 1.2.7 Operating Vacuum (Vacuum Chamber)  
24± 2 inches Hg
- 1.2.8 Inlet Y-Strainer Filtration  
100 mesh
- 1.2.9 Discharge Filter Element Rating  
3μ absolute, with 99.5% minimum; gravimetric efficiency when tested per MIL-F-81836
- 1.2.10 Electrical Power Requirements  
**See Important Engineering Advisory**
- 1.2.11 Hose Connections:
  - 1.2.11.1 Inlet  
1 inch inner diameter minimum; rated for suction and return line service per SAE 100R4
  - 1.2.11.2 Outlet  
¾ inches inner diameter minimum

**Purifier Flow Schematic**

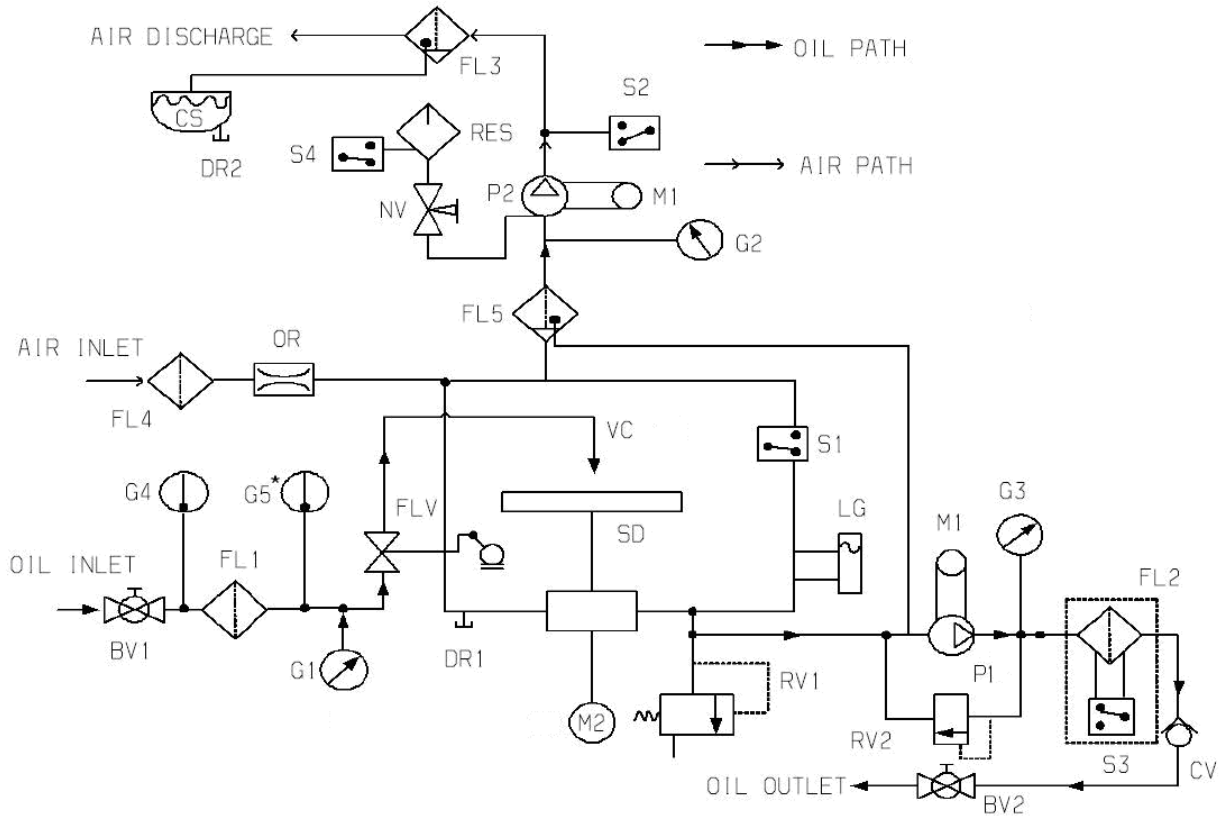

SYM	OBJECT	SYM	OBJECT
BV1	Inlet Ball Valve, 1"	LG	Oil Level Gauge
BV2	Outlet Ball Valve, 3/4"	DR1	Drain Plug - Vacuum Pump
FLV	Float Valve/float Control	DR2	Drain Plug - Coalescer Sump
FL1	Inlet Mesh Strainer, 100 Mesh	SD	Spinning Disc
FL2	Discharge Filter	P1	Discharge Pump
FL3	Coalescing Filter Assembly	P2	Vacuum Pump
FL4	Air Inlet Filter	RES	Vacuum Pump Oiler
FL5	Demister (Air/Oil Filter)	S1	Low Level Switch
VC	Vacuum Chamber	S2	Coalescer Pressure Switch
M1	Main Drive Motor, 1MTR	S3	Delta Pressure Switch
M2	Disc Motor, 2MTR	S4	Oil Level Switch
OR	Air Bleed Orifice	RV1	Chamber Blow Off Valve
G1	Inlet Pressure/Vac. Gauge	RV2	System Relief Valve
G2	Vacuum Gauge	NV	Needle Valve
G3	Outlet Pressure Gauge	CS	Coalescer Sump
G4	Inlet Temperature Gauge	CV	Check Valve
G5*	Water Sensor (optional)		

**Figure 1.1.1 Purifier Flow Schematic**

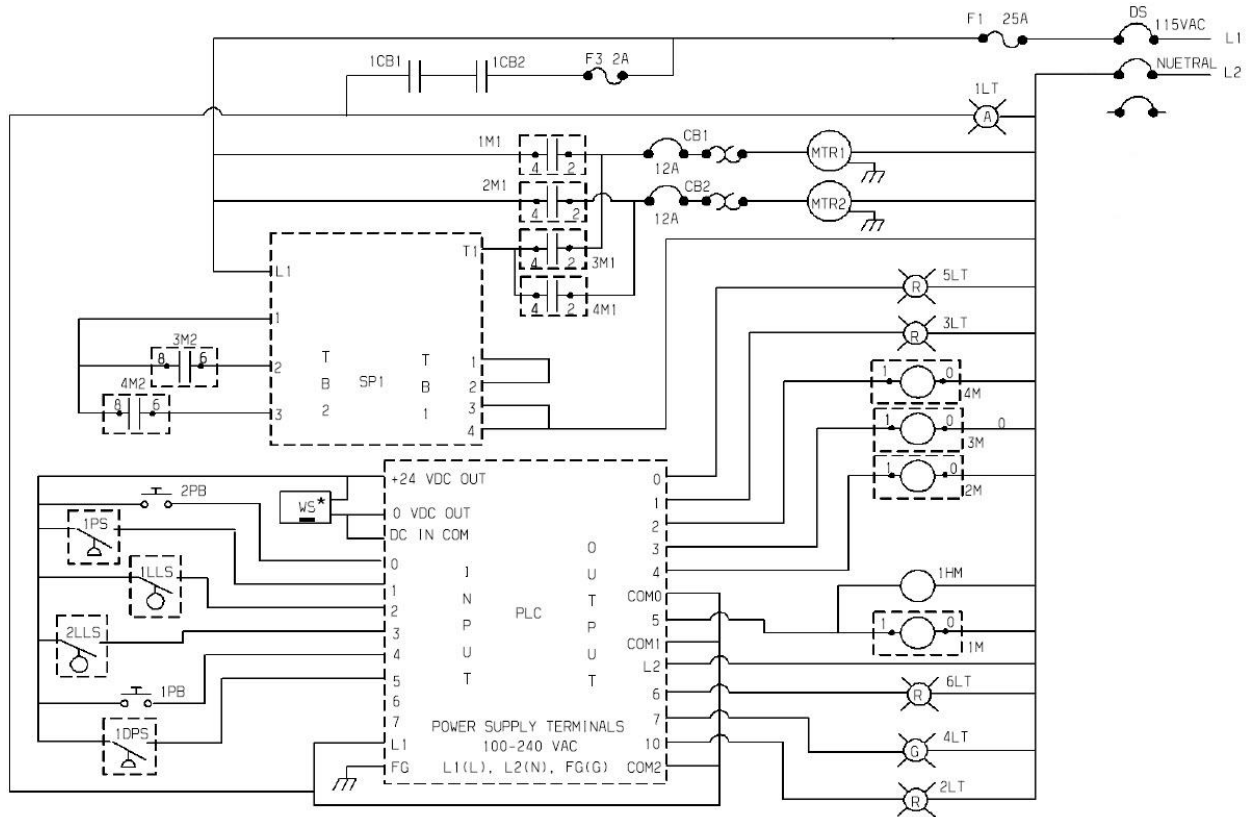

SYM	OBJECT	SYM	OBJECT
WS*	Water Sensor (optional)	1M	Relay Power #1 Coil, Run MTR1
DS	Disconnect Switch	2M	Relay Power #2 Coil, Run MTR2
MTR1	Main Motor	3M	Relay Power #3 Coil, SP1, MTR1
MTR2	Disc Motor	4M	Relay Power #4 Coil, SP1, MTR2
CB1	Circuit Breaker MTR1, 12 Amp	1M1	Relay Power #1 Contacts 1
CB2	Circuit Breaker MTR2, 12 Amp	2M1	Relay Power #2 Contacts 1
1CB1	Circuit Breaker MTR1, Auxilliary	3M1	Relay Power #3 Contacts 1
1CB2	Circuit Breaker MTR2, Auxilliary	3M2	Relay Power #3 Contacts 2
1LT	Power On Light	4M1	Relay Power #4 Contacts 1
2LT	Change Discharge Filter Light	4M2	Relay Power #4 Contacts 2
3LT	Change Coalescer Filter Light	1PB	Push Button 1, Stop
4LT	Unit Run Light	2PB	Push Button 2, Start
5LT	Fill Oiler Light	1DPS	Delta-P Switch, Discharge Filter
6LT	Vac. Chamber Low Fluid Light	1PS	Pressure Switch, Coalescer
G	Green Indicator	1LLS	Low Level Switch, Vac. Chamber
R	Red Indicator	2LLS	Low Level Switch, Vac. Pump Oiler
A	Amber Indicator	1HM	Hour Meter
F1	Main fuse - 25 Amp	SP1	Soft Start
F3	Secondary Fuse - 2 Amp		

**Figure 1.1.2.1 Electrical Schematic for 120 Volt Units**

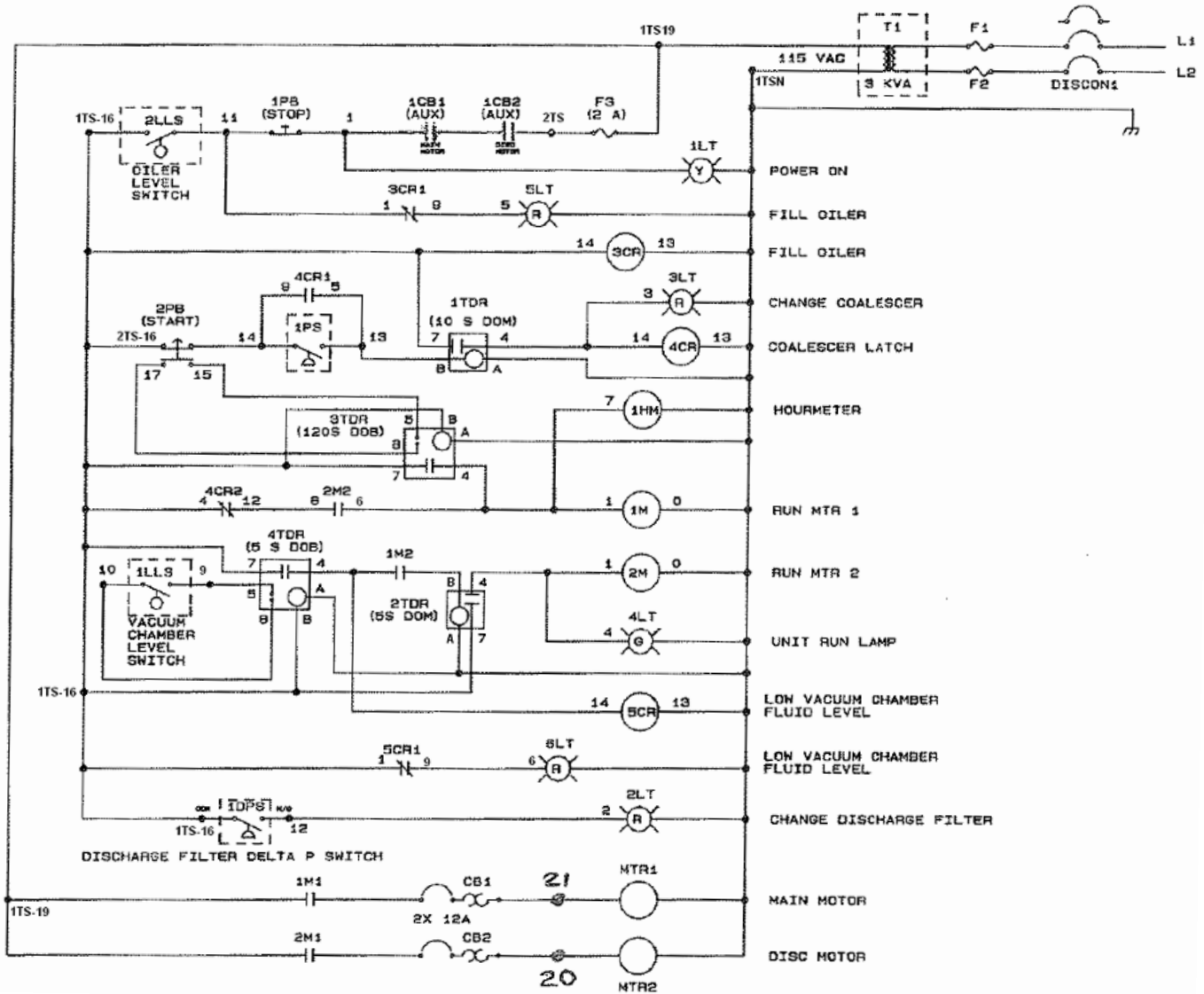

NOTES & SPECIFICATIONS

1. LINE: (L1 & L2) VOLTAGE: 230, 460, OR 575 VAC
2. FUSE: (F1 & F2) RATING: 20A FOR 230 VAC  
15A FOR 460 & 575 VAC

Figure 1.1.2.2a Electrical Schematic for 230, 460 and 575 Volt Units (Built before 01/01/2013)

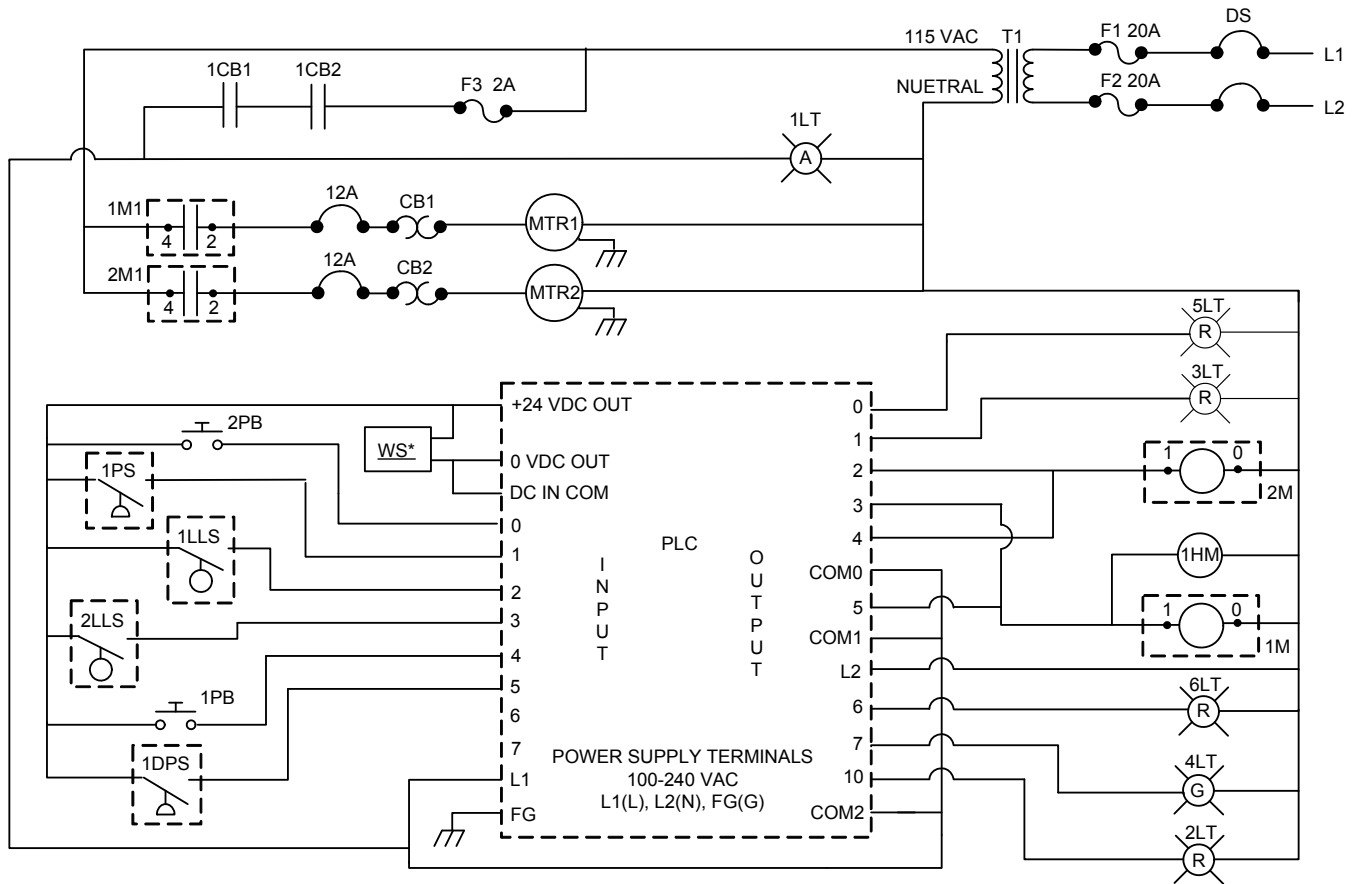

SYM	OBJECT	SYM	OBJECT	SYM	OBJECT
WS*	WATER SENSOR (OPTIONAL)	G	GREEN INDICATOR	1LT	POWER ON LIGHT
DS	DISCONNECT SWITCH	R	RED INDICATOR	2LT	CHANGE DISCHARGE FILTER LIGHT
MTR1	MAIN MOTOR	A	AMBER INDICATOR	3LT	CHANGE COALESCER FILTER LIGHT
MTR2	DISC MOTOR	F1	MAIN FUSE - 25AMP	4LT	UNIT RUN LIGHT
CB1	CIRCUIT BREAKER MTR1, 12AMP	F3	SECONDARY FUSE - 2AMP	5LT	FILL OILER LIGHT
CB2	CIRCUIT BREAKER MTR2, 12AMP	1M	RELAY POWER #1 COIL, RUN MTR1	1DPS	DELTA-P SWITCH, DISCHARGE FILTER
1CB1	CIRCUIT BREAKER MTR1, AUXILARY	2M	RELAY POWER #2 COIL, RUN MTR2	1PS	PRESSURE SWITCH, COALESCER
1CB2	CIRCUIT BREAKER MTR2, AUXILARY	1M1	RELAY POWER #1 CONTACTS 1	1LLS	LOW LEVEL SWITCH, VAC CHAMBER
6LT	VAC. CHAMBER LOW FLUID LOW	2M1	RELAY POWER #2 CONTACTS 1	2LLS	LOW LEVEL SWITCH, VAC PUMP OILER
1HM	HOUR METER	1PB	PUSH BUTTION 1, STOP		
T1	TRANSFORMER, 3KVA	2PB	PUSH BUTTION 2, START		

Figure 1.1.2.2b Electrical Schematic for 230, 460 and 575 Volt Units (Built after 01/01/2013)

## 2.0 OPERATING INSTRUCTIONS

**WARNING**

**DO NOT USE PURIFIER ON ANY FLUID CONTAMINATED WITH EXPLOSIVE OR FLAMMABLE SUBSTANCES. DO NOT USE PURIFIER ON ANY FLUID WITH A FLASHPOINT BELOW 200°F (93.3°C) PER ASTM D 92 OR 180°F (82.2°C) PER ASTM D93.**

**WARNING**

**IF A POSSIBILITY EXISTS THAT THE PROCESS FLUID CONTAINS CONTAMINANTS THAT MAY PRODUCE HAZARDOUS VAPORS (TOXICANTS, IRRITANTS), ENSURE THAT ADEQUATE PRECAUTIONS ARE TAKEN TO CAPTURE OR VENT AWAY VAPORS IN ACCORDANCE WITH LOCAL SAFETY CODES AND APPLICABLE SAFETY PRACTICES. CONNECT A SUITABLE OUTLET LINE (3/4" ID MINIMUM) TO THE COALESCING FILTER OUTLET. IF VAPOR IS PARTICULARLY HAZARDOUS, DISCONNECT DRAIN TUBE FROM COALESCER TO THE HOLDING CONTAINER AND DISPOSE OF COALESCER LIQUID IN A SAFE MANNER ALSO.**

**CAUTION**

PROCESS FLUID MUST BE COMPATIBLE WITH PURIFIER SEALS (SEE SPECIFICATIONS). IF ANY DOUBTS EXIST ABOUT PROCESS FLUID COMPATIBILITY WITH REGARD TO A PARTICULAR PURIFIER UNIT, CONTACT THE PALL AEROPOWER CORPORATION, NEW PORT RICHEY, FL APPLICATIONS ENGINEER (727)849-9999.

**CAUTION**

ENSURE FLUID COMPATIBILITY EXISTS BETWEEN FLUID TO BE PROCESSED AND THE IMMEDIATE, PREVIOUSLY PROCESSED FLUID. IF UNIT IS TO BE USED FOR THE FIRST TIME, DETERMINE COMPATIBILITY BETWEEN FACTORY TEST FLUID AND THE INITIAL PROCESS FLUID. SEE FIT TAGS (ATTACHED TO UNIT) TO DETERMINE FLUID USED DURING FACTORY TESTING. IN BOTH CASES, IF INCOMPATIBILITY EXISTS, FLUSH THE UNIT THOROUGHLY USING THE FLUSHING PROCEDURES IN THE MAINTENANCE SECTION OF THIS MANUAL.

## 2.1 Controls and Indicators

Table 2.1 lists and describes purifier controls and indicators.

<b>TABLE 2.1: Purifier Controls And Indicators</b>	
<b>CONTROL/INDICATOR</b>	<b>FUNCTION</b>
MAIN MOTOR CIRCUIT BREAKER (CB1)	Power application & overload protection for main drive motor MTR1.
DISC MOTOR CIRCUIT BREAKER (CB2)	Power application & overload protection for disc motor MTR2.
START SWITCH	Momentary pushbutton switch—when depressed initiates purifier startup.
POWER ON Lamp	When lit, indicates power is applied to purifier.
CHANGE OR DRAIN COALESCER Lamp	Alarm indicator—when lit indicates unit shutdown due to excess fluid in coalescer sump or clogged coalescer filter element. <b>CORRECTIVE ACTION:</b> change coalescer filter element, empty coalescer sump, restart unit.
CHANGE DISCHARGE FILTER Lamp	Alarm indicator—when lit indicates clogged discharge filter element. Purifier will continue running but will bypass fluid around discharge pump. To reset indicator, change discharge filter element.
UNIT RUN Lamp	When lit, indicates disc motor (MTR2) running and automatic operation.
FILL OILER Lamp	When lit, indicates unit shutdown due to low level in vacuum pump oiler reservoir. <b>CORRECTIVE ACTION:</b> Refill reservoir with SAE 10 WT, restart unit.
LOW VACUUM CHAMBER FLUID LEVEL Lamp	When lit, indicates unit shutdown due to insufficient fluid level in vacuum chamber. Attempt several (2-5) restarts. See troubleshooting section if problem persists.
HOURMETER	Records total unit run time.
ELECTRICAL DISCONNECT SWITCH	Disconnects input power to unit.
STOP SWITCH	Press switch to stop purifier operation. POWER ON lamp will remain lit.
INLET OIL TEMPERATURE Gauge	Monitors temperature of incoming process fluid at purifier inlet port.
OUTLET OIL PRESSURE Gauge	Monitors oil pressure at discharge pump outlet port.
INLET OIL PRESSURE Gauge	Monitors oil pressure at purifier inlet line.
CHAMBER VACUUM Gauge	Monitors vacuum level inside vacuum chamber.
INLET BALL VALVE (OPEN-CLOSE)	Mechanical control for inlet fluid flow into purifier
OUTLET BALL VALVE (OPEN-CLOSE)	Mechanical control for outlet fluid flow from purifier.
OILER DRIP VALVE W/SIGHTGLASS	Used to set drip rate of lubricant (SAE 10 WT) to vacuum pump. <b>Correct setting is 1-3 drops per minute.</b>
VACUUM CHAMBER LIQUID LEVEL SIGHTGLASS	Shows fluid level in vacuum chamber.

## 2.2 Purifier Setup

### CAUTION

INLET AND OUTLET HOSE SIZES SHOULD BE EQUAL TO OR GREATER THAN THE SPECIFIED MINIMUM. ANY SIZE REDUCTION MAY RESULT IN IMPROPER OPERATION OR POSSIBLE MALFUNCTION.

- 1) Connect a 1" ID hose between the purifier inlet port and the fluid reservoir. The inlet hose must be rated for suction and return service per SAE I00R4. In the same manner, connect a ¾" ID hose between the purifier outlet port and the fluid reservoir. Inspect all hose connections for tightness.
- 2) Lift cap of the vacuum pump oiler and fill with a high detergent automotive engine oil (SAE 10), API service rating SB, SC, SE, CB, CD, or a combination of these ratings; or Gast Manufacturing Corp. oil #AD220. DO NOT USE MULTIGRADE OIL SUCH AS 10W40.

### CAUTION

BEFORE APPLYING POWER TO THE UNIT, ENSURE THAT THE POWER SUPPLY WIRING AND OVERCURRENT PROTECTION ARE ADEQUATE FOR THE PURIFIER VOLTAGE AND CURRENT REQUIREMENTS (SEE PURIFIER N/P).

- 3) On the control box assembly, checks that all circuit breakers are closed (ON). Close electrical disconnect switch.
- 4) Connect the purifier to correct power supply, see drawing and purifier nameplate. All lamps on main control box assembly will lit for (5) seconds for lamps verification and then will turn off except the yellow POWER ON lamp 1 LT. With the POWER ON indication available, unit is ready for operation.

## 2.3 Purifier Startup

### NOTE

Fluid processing time is dependent on contaminant level, fluid volume, type and temperature. In general, the purifier should be operated approximately ten (10) minutes per gallon of process fluid.

- 1) Recheck all inlet and outlet hose connections. Open the purifier inlet and outlet ball valves. Open the external (i.e., reservoir) valves as applicable.
- 2) On the control box assembly, depress and release the START switch.
- 3) This will initiate a two minute startup cycle.



**CAUTION**

DURING THE 2 MINUTE STARTUP CYCLE SEVERAL SYSTEM SHUTDOWN MODES ARE DISABLED. THIS IS TO ALLOW THE UNIT TO STABILIZE AND RUN AUTOMATICALLY. DO NOT REPEATEDLY PRESS OR HOLD START BUTTON IF THE SAME FAULT INDICATOR LIGHTS AFTER 2-3 STARTUP ATTEMPTS. FAILURE TO OBSERVE THIS CAUTION MAY CAUSE DAMAGE TO THE UNIT.

- (a) On control box assembly, CHANGE OR DRAIN COALESCER and CHANGE DISCHARGE FILTER lamps should be off. POWER ON lamp should remain lit.
  - (b) OUTLET OIL PRESSURE gauge reading should not exceed 70 PSIG.
  - (c) INLET OIL PRESSURE gauge should read between 10 in. Hg vacuum and + 20 PSIG.
  - (d) INLET OIL TEMPERATURE gauge reading should not exceed +145°F (62°C)
- 4) After 30 to 60 seconds of successful operation, check the CHAMBER VACUUM gauge. Gauge should read between 22 in. Hg and 26 in. Hg vacuum.
  - 5) Observe oiler drip rate, and adjust to 1-3 drops per minute if required.
  - 6) When the green UNIT RUN lamp lights, the unit is running automatically and has successfully completed its startup sequence.

**2.4 Shutdown****NOTE**

The purifier will be shut down automatically if fluid level inside the vacuum chamber falls below a predetermined point (low level shutdown) or whenever the CHANGE OR DRAIN COALESCER lamp lights (indicating a clogged coalescer filter element or a full coalescer sump), or for low vacuum pump oiler level.

- 1) To stop purifier operation, press the red STOP switch on the control box assembly. POWER ON lamp will remain lit.
- 2) Close the purifier inlet and outlet ball valves.
- 3) Disconnect inlet and outlet hoses, if needed.
- 4) Disconnect unit from power supply by opening disconnect switch. POWER ON lamp will extinguish.

### 3.0 MAINTENANCE

#### 3.1 Recommended Spares

Table 3.1 lists recommended spares that should be stocked in quantity indicated to support basic purifier maintenance.

Table 3.1					
PART NUMBER				DESCRIPTION	QTY
PA-00440-D2154				V Belt, Link Type	1
* AA-4463F-1	--	Z	J	Coalescing Filter Element	3
* GC-00273F-168	H	Z	J	Discharge Filter Element	6
* AA-9500-D2288H6				inlet Air Breather Filter	4

\*Also see Purifier I.D. Plate for replacement filters.

#### 3.2 Routine Maintenance

Perform routine maintenance procedures at the specified intervals or as warranted by operating conditions.

##### 3.2.1 Drain Coalescer Sump/Bumper

Place a container under the coalescer sump/bumper drain valve, allow fluid to drain completely, close valve, discard fluid, and check the oil level in oiler reservoir. Drain fluid every 24 operating hours.

##### 3.2.2 Check Vacuum Pump Oiler

- 1) Check vacuum pump oiler level every 24 operating hours. Do not allow oiler level to fall below level switch trip point, or unit will not start.
- 2) When refilling, fill only with SAE 10 oil.

##### 3.2.3 Check Oiler Drip Rate

Check drip rate while unit is operating. Adjust needle valve to 1-3 drops per minute.

#### **CAUTION**

INSUFFICIENT DRIP RATE MAY CAUSE VACUUM PUMP FAILURE. EXCESSIVE DRIP RATE MAY CAUSE COALESCING FILTER ELEMENT TO CLOG PREMATURELY, AND/OR CAUSE SUMP/BUMPER TO FILL PREMATURELY.

##### 3.2.4 Change Discharge Filter Element

Change the discharge filter element whenever the red CHANGE DISCHARGE FILTER lamp on the control box assembly lights. To replace spin-on filter element, proceed as follows:

- 1) Shut down purifier.
- 2) Remove discharge filter spin-on element by rotating counterclockwise. Remove and discard spin-on element seal.
- 3) Lubricate new gasket with process fluid, and install to filter head.
- 4) Install filter onto threaded nipple of head. Turn filter clockwise carefully, to engage threads.
- 5) Tighten filter by hand approximately 3/4 of a turn, after contact with seal.

### 3.2.5 Replace Coalescing Filter Element

Replace the coalescing filter element whenever the red CHANGE OR DRAIN COALESCER lamp on the control box assembly lights. To replace filter element refer to Figure 6-11 in Section 6 and proceed as follows:

- 1) Place a container under the coalescer sump/bumper drain valve, allow fluid to drain completely, close valve, discard fluid, and check vacuum pump oiler (see nameplate on bumper).
- 2) Attempt to restart unit. If it operates automatically, no further action is required. If not, continue with step (3) below.
- 3) Loosen and remove clamp holding filter head to filter bowl.
- 4) Remove filter bowl and slide filter element off the head. It may be necessary to remove tube from bottom of bowl.
- 5) Lubricate O-ring on new filter element before installing. Install new filter element into head and slip bowl over the element.
- 6) Secure the filter bowl to the filter head using the V-band clamp.
- 7) Reconnect drain tube from the coalescer sump/bumper to bottom of bowl if it was removed.

### 3.2.6 Check Inlet Y Strainer

Inspect inlet strainer element whenever reading on INLET OIL PRESSURE gauge drops below 10 in. Hg vacuum. To clean, proceed as follows:

- 1) Close the purifier inlet valve and operate purifier until it shuts down at low level.
- 2) Loosen cap from strainer body and drain.
- 3) Remove hex cap and withdraw the strainer element.
- 4) Clean element with a non-flammable solvent. Blow dry with filtered compressed air.
- 5) Insert strainer element into body. Reassemble seal (O-ring) and cap.

### 3.2.7 Replace Air Breather Element

Change air breather element whenever the pop up indicator on the element actuates. Replace breather element as follows:

- 1) Prior to removing the element, thoroughly clean the old element threads and connection to prevent contaminants from entering the elbow during removal.

#### **CAUTION**

DO NOT USE PIPE TAPE OR SEALING COMPOUNDS ON BREATHER ELEMENT THREADS. ASSEMBLE THE NEW FILTER DRY. TAKE PARTICULAR CARE TO PREVENT CONTAMINANTS FROM ENTERING THE CONNECTION. SEALANTS OR CONTAMINANTS ENTERING THE CONNECTION MAY OBSTRUCT THE INLET AIR ORIFICE, CAUSING EXCESSIVE CHAMBER VACUUM, DISCHARGE PUMP CAVITATION, LOW FLOW RATE, AND REDUCED EFFICIENCY.

- 2) Unscrew the old breather element and discard. Replace with new element, (see element or purifier N/P for replacement element P/N). Hand tighten only. Be sure indicator is installed in element.

### 3.3 Long Term Maintenance

Items in this section should be checked at regular intervals to ensure long life dependable, trouble-free operation.

#### 3.3.1 Inspect Drive Belt

Check the segmented, link type V-belt at three (3) month intervals for wear, oil stains, and tension. Replace worn or oil stained belts. Adjust tension as needed. Refer to Section 5 for V-belt replacement and adjusting procedures.

#### 3.3.2 Inspect Power Cables

Check power cables at six (6) month intervals. Check cables for cuts, abrasion, kinking, and condition of cover. Check cord grips where cable enters electrical enclosures. Replace parts as needed.

#### 3.3.3 Check Indicating Lights

Check all indicating lamps on the control box assembly at twelve (12) month intervals.

#### 3.3.4 Inspect Hoses

Check all oil and air hoses at 24 month intervals for punctures, wear, kinking, abrasions, and condition of inner tube (Liner). Check hose connections for tightness. Replace hoses as required.

### 3.4 Flushing Procedures

#### NOTE

Perform these procedures if fluid to be processed is different from fluid previously processed. If purifier is to be used for the first time, check the F/T tags on unit to determine fluid used during factory testing. Perform these procedures if test fluid is incompatible with fluid to be processed.

- 1) If connected, disconnect inlet hose (customer supplied) from unit and drain.
- 2) Operate purifier until all retained oil is discharged through the discharge hose.
- 3) Disconnect discharge hose and drain.
- 4) Remove vacuum chamber drain plug, drain, and replace.

#### NOTE

If -fluids are highly incompatible, replace spin-on discharge filter element with free flow flushing dummy element (PIN PA-00440-T10) and adapter GB-00550-1 D11 for steps (5) through (8), below.

- 5) Remove spin-on discharge filter element, drain and reassemble. If required, use dummy element (see NOTE, above).
- 6) Reinstall inlet and discharge hoses.
- 7) Flush unit for 15 minutes with approximately 20 gallons of fluid to be processed.
- 8) Drain flushing fluid used in step (6), above, by repeating steps (1) through (4) above. Discard the fluid.
- 9) Install new discharge filter element.
- 10) Unit is now ready for new fluid operation.

### 3.5 Drain Procedures

In order to drain fluid from a flooded vacuum chamber prior to repair or normal operation, proceed as follows:

- 1) Place a container under the drain plug. Follow directions on valve-side guard nameplate, and drain.

### 3.6 Vacuum Pump Purge Procedures

Purge the vacuum pump in the unlikely event that the unit has vented oil from the chamber blowoff valve or the coalescing filter outlet.

#### **WARNING**

**NEVER APPLY AIR PRESSURE TO THE VACUUM CHAMBER/ FAILURE TO HEED THIS WARNING COULD RESULT IN AN EXPLOSION, CAUSING POSSIBLE PROPERTY DAMAGE, INJURY OR DEATH.**

#### **CAUTION**

NEVER RESTART A UNIT WHICH HAS VENTED OIL FROM THE CHAMBER BLOWOFF VALVE OR THE COALESCING FILTER OUTLET WITHOUT PURGING THE VACUUM PUMP AND COALESCING FILTER OF ALL OIL. IF OIL HAS VENTED FROM THE BLOWOFF VALVE AND/OR THE COALESCER, PURGE VACUUM PUMP AS FOLLOWS BEFORE RESTARTING THE MACHINE.

- 1) Disconnect the hose running from the top of the vacuum chamber to the vacuum pump inlet at the vacuum chamber side.
- 2) Drain coalescer sump and remove coalescing filter element. Apply air pressure (15 PSI max) to the vacuum pump inlet via the disconnected hose. DO NOT APPLY PRESSURE TO THE VACUUM CHAMBER. Blow out vacuum pump and lines with air pressure through the free end of the hose connected to the vacuum pump inlet.

## 4.0 TROUBLESHOOTING

### 4.1 Troubleshooting Guide

Table 4.1 lists possible malfunctions that may occur during purifier operation, their probable causes and suggested remedies. To aid troubleshooting, refer to the electrical schematic, Figure 1.1.2.1 or 1.1.2.2a or 1.1.2.2b and the purifier flow schematic, Figure 1.1.1. For component replacement procedures, refer to Chapter 4 of this manual. Should an unlisted problem occur or if a suggested remedy fails to correct a problem, notify Pall Aeropower Corporation, New Port Richey, FL Attn: applications Engineer.

<b>Table 4.1</b>		
<b>SYMPTOM</b>	<b>PROBABLE CAUSE</b>	<b>REMEDY</b>
<p>Persistent low fluid level condition, UNIT RUN lamp will not energize. Purifier shuts down 2 minutes after releasing START button. LOW VACUUM CHAMBER FLUID LEVEL lamp energizes.</p>	<p>Partially or fully closed inlet valve. Suspect this if INLET OIL PRESSURE GAUGE indicates high vacuum (above 10 in. Hg.)</p> <p>Dirty or clogged inlet strainer. Suspect this if INLET OIL PRESSURE GAUGE indicates high vacuum (above 6 in. Hg.).</p> <p>Undersize or otherwise clogged inlet line. Suspect this if INLET OIL PRESSURE gauge indicates high vacuum (above 6 in. Hg).</p>	<p>Open inlet valve for inlet pressure reading between -10 in. Hg and +20 psig while unit is running.</p> <p>Disassemble, clean and reassemble strainer.</p> <p>Use correct inlet size; clear inlet line as needed.</p> <p style="text-align: center;"><b><u>WARNING</u></b>  <b>TO AVOID DANGER OF EXPLOSION, DO NOT APPLY POSITIVE AIR PRESSURE TO THE PURIFIER INLET AT ANY TIME.</b></p> <p style="text-align: center;"><b><u>CAUTION</u></b>  MAXIMUM PURIFIER INLET OIL PRESSURE IS 20 PSIG. CUSTOMER IS RESPONSIBLE FOR DETERMINING MAXIMUM PRESSURE OF ANY CONNECTED SYSTEM. TAKE CARE NOT TO OVER PRESSURIZE THE PURIFIER OR ANY CONNECTED COMPONENT.</p>

<b>Table 4.1 (Continued)</b>		
<b>SYMPTOM</b>	<b>PROBABLE CAUSE</b>	<b>REMEDY</b>
	<p>Leak in suction plumbing between fluid reservoir and vacuum chamber. Suspect this is INLET OIL PRESSURE gauge reads normal, inlet valve is fully open, and unit will not fill within 5 minutes.</p> <p>Inlet line not submerged below reservoir fluid level or inlet line stuck on bottom of reservoir.</p> <p>Excessively high fluid viscosity. Suspect this if INLET OIL PRESSURE gauge indicates high vacuum and inlet valve is fully open.</p> <p>Float valve stuck in closed position.</p> <p>Defective low level switch (1LLS) or reverse polarity on switch. Suspect this if removal of upper chamber shows the level switch float all the way up against its stop (fluid level is higher than switch and LOW VACUUM the unit identify and correct CHAMBER FLUID LEVEL lamp is lit).</p>	<p>Find and repair leaks as required. To find leaks, carefully apply positive OIL pressure to purifier inlet. (+20 psig max.)</p> <p>Correct either condition.</p> <p>Reduce oil viscosity by heating.</p> <p style="text-align: center;"><b>NOTE</b></p> <p>MAXIMUM PURIFIER OPERATING TEMPERATURE IS +145°F (62°C). MAXIMUM PURIFIER FLUID VISCOSITY IS 1300 SSU.</p> <p>Remove upper chamber. Free float ball linkage. Determine and correct cause of binding. Replace float valve assembly if required.</p> <p>Reverse polarity of switch by removing its retaining clip and inverting float. Replace retaining clip. Check that clip snaps in securely. If polarity is correct and lamp is still lit with float all the way up, replace switch. Before reassembling the unit identify and correct cause of switch failure. Also check float for buoyancy and free travel throughout its range.</p>

<b>Table 4.1 (Continued)</b>		
<b>SYMPTOM</b>	<b>PROBABLE CAUSE</b>	<b>REMEDY</b>
One or both motors operate for only 2 minutes after START button is released. CHANGE OR DRAIN COALESCER lamp lights.	Full coalescer sump and/or coalescer filter element clogged.	Drain coalescer sump. (See nameplate on bumper), allow coalescer housing to drain completely. Discard fluid. Close drain valve and restart. If lamp turns on again and unit stops 2 minutes after START switch is released, replace filter element.
	Defective or misadjusted pressure switch 1PS.	Replace or readjust switch.
	Misadjusted or defective time delay relay 1TDR or bad relay connections (for units w/relay board).	Check relay and connections. Rewire, replace, or readjust.
	Improperly programmed or defective PLC/Expansion Module (for units w/PLC).	Return PLC and expansion module to factory for analysis, reprogramming, or replacement.
	Obstruction, kink, or restriction in vacuum pump or exhaust line.	Clear line.



<b>Table 4.1 (Continued)</b>		
<b>SYMPTOM</b>	<b>PROBABLE CAUSE</b>	<b>REMEDY</b>
Unit stops and does not restart when START button is depressed. (Both motors fail to start).	Circuit breaker tripped (CB1 or CB2).	Find and correct cause of overload. Reset all tripped breakers.
	Overcurrent protection in power receptacle or power lines has opened.	Reset/replace as required.
	Vacuum pump oiler level is low. Suspect this if FILL OILER lamp is lit.	Refill oiler with SAE 10 WT. Restart unit.
	Blown fuse(s) in control box.	Find and correct cause of overload.
	Main disconnect switch is OFF.	Turn switch to ON. Restart unit.
	Damaged transformer or soft start module.	Replace. Rewire per schematic.
	Defective START (2PB) or STOP switch (1PB).	Determine which switch is defective and replace.

<b>Table 4.1 (Continued)</b>		
<b>SYMPTOM</b>	<b>PROBABLE CAUSE</b>	<b>REMEDY</b>
High vacuum indicated on INLET OIL PRESSURE gauge, above 10 in. Hg.	Dirty inlet strainer.	Remove, clean and reassemble.
	Undersized inlet line or clogged inlet line.	Use 1" ID (SAE 100R4) lines (min) or clear obstructed lines.
	Excessively high oil viscosity (greater than 1300 SSU)	Reduce oil viscosity by heating to 145°F (62°C) maximum.
	Contaminated fluid reservoir too far below purifier, or inlet line too long.	Lower purifier or use boost pump (P/N PD-00440BSTPMP[G]A) to raise purifier inlet pressure.
	Excessively high chamber vacuum (greater than 26 in. Hg).	Replace breather element and check for obstruction in inlet orifice.
	Defective inlet pressure gauge.	Replace.

<b>Table 4.1 (Continued)</b>		
<b>SYMPTOM</b>	<b>PROBABLE CAUSE</b>	<b>REMEDY</b>
<p>OUTLET OIL PRESSURE gauge reads above 60 psi. CHANGE DISCHARGE FILTER lamp not lit.</p>	<p>Clogged discharge filter and/or burnt out lamp 2LT.</p>	<p>Change filter. Check and replace lamp if needed.</p>
	<p>Defective differential pressure switch 1DPS.</p>	<p>Check differential pressure across filter by connecting differential pressure gauge as follows:</p> <p>a. Disconnect line to PUMP OUTLET PRESSURE and reconnect to the high pressure port of the differential pressure gauge.</p> <p>b. Place <math>\frac{3}{4}</math>" tee immediately downstream of the purifier outlet ball valve. Connect low pressure port of differential pressure gauge to this tee.</p> <p>c. Operate the machine. If the differential pressure gauge shows a differential pressure of more than 58 psig, the indicating lamp checked out OK but still does not light, the differential pressure switch is defective. Replace it.</p>
	<p>Closed outlet ball valve.</p>	<p>Open valve.</p>
	<p>Undersized or clogged outlet line.</p>	<p>Increase outlet line size or clear line as needed.</p>
	<p>Defective gauge.</p>	<p>Replace gauge.</p>

<b>Table 4.1 (Continued)</b>		
<b>SYMPTOM</b>	<b>PROBABLE CAUSE</b>	<b>REMEDY</b>
CHANGE DISCHARGE FILTER lamp lit.	Clogged filter.	Replace filter.
	Excessively high viscosity.	Reduce oil viscosity by heating. Do not exceed 145°F(62°C)
CHANGE DISCHARGE FILTER lamp is lit. OUTLET OIL PRESSURE gauge reads normal, below +25 psig.	Defective differential pressure switch 1DPS.	Replace pressure switch.
	Defective OUTLET OIL PRESSURE gauge.	Replace gauge.
High vacuum indicated on CHAMBER VACUUM gauge, above 26 in. Hg.	Clogged inlet air breather element.	Replace inlet air breather element.
	Obstruction in air inlet orifice.	Remove air breather element. Remove elbow from the upper vacuum chamber and clear orifice.
	Defective vacuum gauge.	Replace gauge.
High pressure indicated on INLET OIL PRESSURE gauge, above 20 psig.	Fluid or inlet reservoir pressure exceeds +20 psig.	Install a pressure regulator (P/N AA-9500-D1818[G]A) set between 0 and +10 psig just before the inlet valve to reduce the inlet pressure.
	Defective gauge.	Replace gauge.
INLET OIL TEMPERATURE gauge reads above 145°F(62°C)	Process fluid too hot.	Lower hose connection on fluid reservoir. Use purifier when system is cooler (i.e. when system is shutdown). Use a heat exchanger to reduce oil inlet temperature.
	Defective gauge.	Replace gauge.
	Purifier is circulating a very small quantity of oil.	Increase volume of process fluid.

<b>Table 4.1 (Continued)</b>		
<b>SYMPTOM</b>	<b>PROBABLE CAUSE</b>	<b>REMEDY</b>
Low vacuum indicated on CHAMBER VACUUM gauge (below 22 in. Hg).	Leak in inlet or gauge line plumbing.	Find and repair leak.
	Defective vacuum gauge.	Replace.
Low vacuum pump outlet and/or excessive noise.	Vacuum pump problems.	See next item; low vacuum pump output and/or excessive noise.
	Plugged coalescing filter element and defective coalescer pressure switch.	After unit has run automatically for 2 minutes, check pressure switch by plugging coalescer exhaust port and bumper vent orifice completely. If unit does not shut down within 10-40 seconds, pressure switch is defective. Replace switch. Also replace coalescing filter element. Restart the unit and check CHAMBER VACUUM gauge. If level remains below 22 in. Hg vacuum pump is damaged. Replace vacuum pump.
	Insufficient oiler drip rate.	Adjust to 1-3 drops per minute.
	Broken pump vane.	Replace pump.
<p style="text-align: center;"><b>NOTE</b></p> <b>Pall Corp. does NOT recommend rebuilding the vacuum pump.</b>	Loose or defective drive coupling.	Tighten or replace.
	Vane(s) sticky & hung up.	Disassemble line from top of chamber to vacuum pump. Spray several shots of nonflammable solvent into pump inlet with pump running. Follow by several shots of WD-40. If problem persists, replace pump.
	Vacuum pump worn out.	Replace.

<b>Table 4.1 (Continued)</b>		
<b>SYMPTOM</b>	<b>PROBABLE CAUSE</b>	<b>REMEDY</b>
<p>CHANGE OR DRAIN COALESCER lamp lit. Unit shuts down.</p> <p>High chamber oil level keeps shutting down system (chamber will not drain)</p> <p style="text-align: center;"><b>NOTE</b></p> <p><b>High chamber level is indicated by the disc motor (MTR2) circuit breaker (CB2) repeatedly tripping out shortly after depressing START button. The chamber level sight gauge will also be full of oil for this condition.</b></p>	Full coalescer sump.	Drain coalescer sump/bumper (see nameplate). Check oiler and restart unit. If unit shuts down again and lamp turns on, replace coalescing filter element.
	Plugged coalescer filter.	Drain sump. Replace coalescer element.
	Defective float valve assembly.	Replace float valve assembly.
	Leaking poppet gasket.	Replace float valve assembly.
	Float ball full of oil.	Replace ball.
	Float valve linkage binding open.	Remove upper chamber. Free linkage. Determine and correct cause of binding. Replace float valve assembly if needed.
	Inlet pressure greater than +20 psig.	Install a pressure regulator (P/N AA-9500-D1818[G]A) set between 0 and +10 psig at the inlet connection to reduce inlet pressure.
	Float valve seat not bottomed in valve body.	Remove fittings from valve inlet. Remove seat. Clean seat and valve body. Drain chamber if needed. Apply Loctite 242 or equivalent to seat threads. Reassemble and bottom seat. Reassemble fittings.

<b>Table 4.1 (Continued)</b>		
<b>SYMPTOM</b>	<b>PROBABLE CAUSE</b>	<b>REMEDY</b>
Disc motor (MTR2) circuit breaker (CB2) keeps tripping out. Chamber level sight glass does not show full of oil.	Defective circuit breaker CB2. Check disc motor current with Amprobe.	Replace.
	Disc has spun off motor shaft.	Replace disc and setscrew. Install disc & setscrew with Loctite 242
	Mechanical seal worn out.	Replace mechanical seal/plate assembly, sealing washers, and mechanical o-ring.
	Defective power transformer.	Replace transformer.
	Disc motor (MTR2), damaged, shorted or defective. (Check capacitors and start switch).	Replace motor, sealing washers and mechanical seal o-ring.
	Out of adjustment or defective soft start module.	Return entire module to factory for analysis, readjustment, or replacement.
Main motor (MTR1) circuit breaker (CB1) keeps tripping out.	Defective circuit breaker CB1. Check main motor (MTR1) current with Amprobe.	Replace circuit breaker.
	Main motor (MTR1) overloading due to vacuum pump, discharge pump or drive freeze-up.	Check entire drive for free movement. Replace or adjust components as required.
	Damaged, shorted or defective main motor (MTR1). (Check capacitor & start switch.)	Replace main motor.
	Defective power transformer.	Replace transformer.
	Circuit breaker CB1 over heating due to frequent and repeated start-ups( jogging or plugging main motor).	Reset breaker. Allow to cool for 5 minutes. Restart. Do not job or plug excessively.
	Improperly programmed or defective PLC or expansion module.	Return PLC & expansion module to factory for analysis, reprogramming, or replacement

## 5.0 OVERHAUL AND REPAIR

### 5.1 General Information

This chapter provides repair, replacement and overhaul procedures for major components of the portable purifier. Procedures are arranged by major component groupings following, as applicable, a logical sequence for - removal of parts. Paragraphs are cross-referenced where needed, to avoid repetition of detail. Unless otherwise indicated, repair is done by replacement of a damaged part.

Prior to initiating repair or replacement procedures refer to the troubleshooting section in the MAINTENANCE chapter of this manual to determine cause of malfunction. This is to limit extent of disassembly only as needed to effect necessary repair without a complete unit teardown. Refer also to the purifier flow schematic, Figure 1.1.1, and the electrical schematic, Figure 1.1.2.1 or 1.1.2.2a or 1.1.2.2b.

To aid in locating and identifying components, item numbers (in parentheses) appearing in the text are keyed to the components shown and listed in the ILLUSTRATED PARTS LIST, SECTION 6.

Applicable replacement parts, special tools, and bulk materials required for repair or replacement are listed at the beginning of each major component grouping. Inspection, cleaning, and adjustment procedures are detailed in the paragraphs to which they apply.

Any correspondence with the manufacturer or its local representatives should include the purifier's complete part number and serial number as shown on its identification plate.

Reference Table 5.1.1 or Table 5.1.2 to assure seal reference compatibility with fluid being processed.

<b>Code [G]<sup>2</sup></b>	<b>Seal Material</b>	<b>Fluid Serviced</b>
H	Buna N	Petroleum
Z	Viton	Petroleum, Specified Synthetics
J	EPR	Type IV Phosphate Esters (Skydrol 500)

Where uniform O-rings are identified by uniform size, specify O-ring compound per Table 5.1.2 to assure compatibility with fluid being processed.

<b>P/N O-Ring Compound</b>	<b>Seal Material</b>	<b>Fluid Serviced</b>
MS28775-	Buna N	Petroleum
M832481-	Viton	Petroleum, Specified Synthetics
NAS1611-	EPR	Type IV Phosphate Esters (Skydrol 500)

Example: MS28775-327 indicates "uniform size -327" O-Ring with Buna N seals for petroleum base fluid being serviced.



## 5.2 Removal and Replacement of Upper Vacuum Chamber, V-Band Clamp, O-Ring, Vacuum, Seal Retainer and Feed Tube/Tube Fitting Assembly.

<b>Table 5.2—Requirements</b>		
<b>ITEM</b>	<b>PART NUMBER</b>	<b>QTY</b>
<b>REPLACEMENT PARTS: (AS NEEDED)</b>		
V-Band Clamp	AA-9500-D1940	1
O-Ring	AA-9500-D1939[G]	1
Vacuum Seal Retainer	PA-00440-VCD3[G]A	1
Feed Tube/Fitting Assembly	PB-00440-1D23A	1
<b>BULK MATERIALS:</b>		
Pipe Sealant with Teflon Grease or Vaseline	Loctite PST #592 or equivalent	A/R A/R
<b>REQUIRED TOOLS:</b>		
Soft Faced Mallet		1
3/8" Drive Ratchet Wrench and 7/16" deep well socket	PB-00440-T33	1
Feed Tube Adjusting Tool		1
6" Scale		1
Dial Calipers		1

### 5.2.1 Upper Vacuum Chamber and V-Band Replacement

- 1) Pump fluid out of unit by operating in manual position.
- 2) Disconnect all hoses from top of upper vacuum chamber. Remove breather filter (6-2-12) if needed.
- 3) Unthread nut to loosen V-band clamp (6-6-2). Remove V-band clamp and separate upper vacuum chamber from lower vacuum chamber.
- 4) Remove O-ring (6-6-1) and vacuum seal retainer (6-6-3). Inspect O-ring, retainer, V-band clamp, and upper vacuum chamber for cleanliness and damage or deterioration.
- 5) Remove feed tube/fitting assembly (6-2-10) from upper vacuum chamber in accordance with paragraph 5.2.2, below.

#### NOTE

Anytime the upper vacuum chamber is removed, fill the lower vacuum chamber (after any necessary repairs) with clean process fluid to a height of 2 inches below the sealing lip. This will prevent damage to the discharge pump due to dry start-up and prolong pump life. Clean and inspect all removed components.

- 6) Replace any damaged component. If removed reinstall feed tube/fitting assembly (6-2-10) onto lower vacuum chamber in accordance with paragraph 5.2.2 below. Reinstall breather filter (6-2-12) onto upper vacuum chamber.
- 7) Lubricate O-ring (6-6-1), flange lips of upper and lower vacuum chambers and inside of V-band clamp liberally with light grease or Vaseline. Install vacuum seal retainer into lower vacuum chamber. Slip O-ring (6-6-1) over retainer (6-6-3). Position upper vacuum chamber over lower vacuum chamber and reconnect hoses.

- 8) Position V-band clamp (6-6-2), and start the V-band nut onto the V-band tightening screw. Using 3/8" drive ratchet wrench and 7/16" deep well socket; slowly tighten the V-band nut. Do not use an impact wrench, nut runner, screw gun, or other high speed tool. Tap around the outside circumference of the V-band clamp lightly with a soft faced mallet while tightening the V-band nut. Do not over-tighten.

### 5.2.2 Feed Tube and Tube Fitting Replacement

- 1) Replace the feed tube/fitting assembly (6-2-10) only if kinked, collapsed, split, or otherwise damaged. In cases of extreme shock encountered in transit, handling, or usage, tube centering (concentricity) in relation to the disc (6-2-9) or the gap between the tube and the disc may require adjustment. Specifications for tube position are as follows:
  - a) Concentricity of tube OD to disc centerline: .030 inch (0.762 mm), total indicator readings.
  - b) Vertical distance between tube and disc surface: 0.25" +.125/-.030 inch (6.35 +3.12/-0.76 mm)
  - c) Parallelism between tube end and disc surface: 0.100 inch (2.54 mm).
- 2) The misaligned feed tube may be realigned in the machine by use of the feed tube adjusting tool PB-00440-T33 or tapping with a soft faced mallet. In some cases, tube removal will be required in order to use a vise or bender on the tubing.

#### NOTE

The replacement feed tube/fitting assembly has the ferrule preset on the tube. The tube is preformed to be near the correct position. Final installation, inspection, and positioning are performed on the individual machine by the customer.

- 3) To remove the feed tube/fitting assembly (6-2-10), first remove the upper vacuum chamber in accordance with paragraph 5.2.1.
- 4) Loosen tube nut until completely disengaged. Remove tube, sleeve (locked to tube) and nut. Discard.
- 5) Remove tube fitting body and discard. Wipe inside of coupling clean.
- 6) Disassemble adapter body from spare feed assembly by unthreading tube nut. Apply light oil to adapter body threads. Bottom tube in adapter body. Wrench nut down gradually until a sudden torque increase is felt. Tighten the nut an additional 1/6 turn (one wrench flat) from this point.
- 7) Install adapter body into the 3/4" weld coupling in the lower vacuum chamber. Wipe off any excess sealant. Assemble tube, sleeve, and nut. Apply light oil to adapter body threads. Bottom tube in adapter body. Wrench nut down gradually until a sudden torque increase is felt. Tighten the nut an additional 1/6 turn (one wrench flat) from this point.
- 8) Set vertical gap and parallelism with a 6" scale. Adjust gap to the specified distance in step (1) above.
- 9) Set concentricity by centering feed tube with respect to disc. Use DIAL CALIPERS to measure from the O.D. of the feed tube. Take four (4) measurements, relative to the axis of the main body of the feed tube. All four readings should be 5.625" +/- .015. Use feed tube adjuster #PB-00440-T33 or soft-faced mallet. Refer to step (1) above.
- 10) Adjust tube until concentricity, vertical gap, and parallelism are within limits specified in step (1) above.
- 11) Reinstall upper vacuum chamber in accordance with paragraph 5.2.1, above.

### 5.3 Replacement of Spinning Disc, Motor Sealing Washers, Mechanical Seal/Seal Plate Assembly, O-Ring, and Disc Drive Motor.

<b>Table 5.3—Requirements</b>		
<b>ITEM</b>	<b>PART NUMBER</b>	<b>QTY</b>
Disc	PA-00440-VCD4A	1
Sealing Washers	AA-9500-D1985[G]	4
Mechanical Seal/Plate Assy.	PA-004400-DVC5[G]A	1
Motor, Disc Drive	AB-9500-D4136	1
Setscrew	AA-9500-D2115	1
O-ring	Uniform size -327	1
Motor Bolts (optional) (3/8-16 x 1")	AA-9500-D846	4
Threadlock	Loctite 242 or equivalent	A/R
Pliable Gasket Compound Non-Hardening		A/R
Clean Process Fluid	Permatex #2 or equivalent	A/R
Seal Alignment and Installation Tools	PB-00440-T30 & T31	1

#### 5.3.1 Disc Replacement

- 1) Pump all oil out of the unit by closing the inlet valve and running the unit for approximately two (2) minutes after the low level switch shuts off the disc motor.
- 2) Disconnect unit from its electrical power supply.
- 3) Disconnect all vacuum hoses running to the upper vacuum chamber at the vacuum chamber side.
- 4) Remove upper vacuum chamber per paragraph 5.2.1.
- 5) Remove guard (6-1-34) from valve side of the machine.
- 6) Remove the feed tube (6-2-10). See Feed Tube/Tube Fitting Replacement, paragraph 5.2.2 removal procedures. Remove setscrew from disc hub.
- 7) Remove the access cover(s) from the disc motor bottom. Below the cover, grasp the motor shaft. This shaft end is either slotted or has flats machined on it. Hold this shaft steady and unthread the disc (6-2-9) by rotating it counterclockwise.
- 8) Lubricate rubber portion of the new mechanical seal which grips the drive motor shaft and mating surface of the mechanical seal with clean process fluid. Do not use grease. Install on the motor shaft using tools #PB-00440-T30 and #PB-00440-T31.

- 9) Apply Loctite 242 to threads on end of disc motor shaft. Position disc on protruding end of drive motor shaft and turn disc clockwise until it bottoms out. Hold bottom end of drive shaft steady to facilitate disc installation. Tighten disc securely to shaft. Install setscrew using Loctite 242.
- 10) Reinstall and realign feed tube (6-2-10) with the disc (6-2-9) in accordance with paragraph 5.2.2.
- 11) Replace cap over bottom end of disc motor drive shaft. Reinstall guard (6-1-34).

NOTE

Anytime the upper vacuum chamber is removed, fill the lower vacuum chamber with clean process fluid to a height of 2 inches below the sealing lip. This will prevent damage to the discharge pump due to dry start-up and prolong pump life and reliability.

- 12) Reinstall upper vacuum chamber per paragraph 5.2.1.

### 5.3.2 Sealing Washer Replacement

NOTE

Replace used sealing washers (6-7-1) with new ones anytime they are removed for whatever reason. Lubricate both sides of new sealing washers with clean process fluid before installing.

NOTE

Sealing washer replacement does not require disc (6-2-9) or disc motor (6-7-5) removal.

- 1) Remove upper vacuum chamber in accordance with paragraph 5.2.1.
- 2) Remove and replace bolts (6-7-2) and sealing washers (6-7-1) holding disc motor (6-7-5) and seal plate to the lower vacuum chamber one at a time in alternate fashion. Remove and replace each bolt and washer set before proceeding to next set.
  - a) Clean and inspect each bolt as it is removed. Separate and discard used sealing washer. Remove cured thread lock from bolt with wire brush and check for stripped or damaged threads. Discard stripped or damaged bolts.

NOTE

Bolt and mating surfaces on lower vacuum chamber should be clean and free from chips, loose paint, dirt or other particles that could damage the sealing washer and result in a serious leak. A damaged seal could allow air into the chamber while operating under vacuum. With purifier off (zero vacuum) a damaged seal could also cause process fluid to drip out of the chamber, resulting in damage to purifier drive components and posing possible safety hazards such as electrical shorts.

- b) Assemble sealing washer (6-7-1) to bolts (6-7-2). Lubricate inner diameter of washer with clean fluid and push gently up on bolt until flush against the hex head. Lubricate both sides of washers sparingly with clean fluid. Wipe any fluid off first four bolt threads. Apply Loctite 242 sparingly on the first two or three bolt threads. Install replacement bolt and washer and proceed to next seal.

**INSTALLATION TORQUE: 150 INCH-LBS**

- 3) Install upper vacuum chamber in accordance with paragraph 5.2.1.

## 5.3.3 Mechanical Seal/Seal Plate Assembly Replacement

**CAUTION**

DO NOT ATTEMPT TO REMOVE STATIONARY PORTION OF THE MECHANICAL SEAL FROM THE MECHANICAL SEAL PLATE. THESE ARE FACTORY PRESSED AND SEALED. DISASSEMBLY MAY RESULT IN A LEAK.

- 1) Remove upper vacuum chamber and spinning disc in accordance with paragraphs 5.2.1 and 5.3.1.
- 2) Remove two discharge pump, lock washers, flat washers, and hex nuts. Remove V-belt and slide discharge pump (6-4-5) out from under the disc motor (6-7-5) to provide sufficient clearance for disc motor removal from the lower vacuum chamber. Remove the wire junction cover plate from the lower vacuum chamber. Remove the wire junction cover plate from the bottom of the motor. Tag and disconnect wires from the motor to the control box. Disconnect and remove the cable from the disc motor (6-7-5).
- 3) Remove rotating portion of seal from motor shaft and discard. Support the motor from the bottom. Loosen four bolts (6-7-2) which hold mechanical seal plate assembly and the motor in an alternating pattern, approximately one turn at a time to avoid springing the lower vacuum chamber. When all four bolts have been removed, withdraw the disc motor (6-7-5) from the purifier.
- 4) Remove the mechanical seal/seal plate assembly (6-7-4) from the lower chamber. Retain the twelve spacing washers (6-7-3, three per bolt.) Discard the mechanical seal/seal plate assembly (6-7-4) and seal O-ring (6-7-6).
- 5) Lubricate replacement O-ring (6-7-6) with clean process fluid and stretch over hub of new seal plate (6-7-4). Lubricate face of mechanical seal with light oil or clean process fluid. Do not use grease or heavy oil as an installation lubricant as these may cause seal leakage. Take care at all times not to nick or damage either mating surface of the mechanical seal. To ease installation of the spacing washers (47), align and bond washers together in sets of three with a light film of sealant such as Permatex #2 non-hardening gasket compound.
- 6) Position bonded spacing washers over (6-7-3) motor (6-7-5) mounting holes. Install new sealing washers (6-7-1) on bolts (6-7-2) per paragraph 5.3.2. Position seal plate (6-7-2) with attached O-ring (6-7-6) over spacers (6-7-3) and motor (6-7-5) so that mounting holes are aligned.
- 7) Install motor (6-7-5), seal plate (6-7-4) with spacing washers (6-7-3) beneath lower vacuum chamber. Ensure motor is adequately supported while installing bolts (6-7-2) with attached sealing washers (6-7-1) from upper side of chamber. Tighten bolts (6-7-2) approximately one turn at a time on alternating pattern to avoid springing the lower vacuum chamber.
- 8) Lubricate the rubber shaft gripper on rotating portion of mechanical seal with clean process fluid, and install on the motor shaft with its polished steel face down. Use tools #PB-00440-T30 and PB-00440-T31. Apply light machine oil or clean process fluid to steel face of seal. Do not use WD-40, silicone, oils, or grease.
- 9) Reinstall disc (6-2-9) in accordance with paragraph 5.3.1. Rewire the disc drive motor (6-7-5) as tagged and reinstall the discharge pump (6-4-5). Reinstall upper vacuum chamber per paragraph 5.2.1.

## 5.3.4 Disc Drive Motor Replacement

**WARNING**

**INSPECT THE REPLACEMENT DISC MOTOR (5) FOR MARKING INDICATING ABSENCE OF ANY THERMAL OVERLOAD PROTECTION. ANY MOTOR USED TO DRIVE THE DISC MUST BE WITHOUT INTERNAL OVERLOAD PROTECTION. USE OF A MOTOR WITH THERMAL OR OTHER TYPE OF INTERNAL OVERLOAD PROTECTION MAY RESULT IN AUTOMATIC RESTARTING, POSING POTENTIAL SAFETY HAZARDS DURING MAINTENANCE (FOR INSTANCE, IF THE DISC WERE TO RESTART AUTOMATICALLY WITH THE UPPER VACUUM CHAMBER REMOVED, POWER CONNECTED WITH AN OPERATOR OR MECHANIC WORKING ON THE INSIDE OF THE VACUUM CHAMBER). FOR REPLACEMENT PURPOSES, USE ONLY MOTORS SUPPLIED BY PAC UNDER P/N PA-00440-D4136A.**

- 1) Remove upper vacuum chamber, disc (6-2-9), discharge pump (6-4-5), mechanical seals (6-7-1) and motor (6-7-5) in accordance with the preceding paragraphs 5.2.1, 5.3.1 and 5.3.3. Do not discard mechanical seal (6-7-1) and O-ring (6-7-6) unless they are damaged.
- 2) Examine both faces of the mechanical seal and mechanical seal O-ring for damage. Replace if required. Always replace the sealing washers.
- 3) Reinstall the disc drive motor in accordance with paragraph 5.3.3, step, above. Be sure to install new sealing washers and to lubricate all seals correctly per paragraph 5.3.2 before installing.

#### 5.4 Removal and Replacement of Float Valve Assembly and Float Ball

<b>Table 5.4—Requirements</b>		
<b>ITEM</b>	<b>PART NUMBER</b>	<b>QTY</b>
<b>REPLACEMENT PARTS: (AS NEEDED)</b>		
Float Ball	AA-9500-D1968	1
Float Valve Assembly	AB-A352-8D999H	1
Float Valve Gasket	AB-A351-12D92H	1
O-Ring	Uniform size -372 (see Table 5.1.2)	1
Sealing Washers	AA-9500-D1985[G]	4
<b>BULK MATERIALS:</b>		
Clean Process Fluid		A/R
Pipe Sealant with Teflon	Loctite PST #592 or equivalent	A/R
Gasket Compound, Non-hardening	Permatex #2 or equivalent	A/R

##### 5.4.1 Float Ball and Float Valve Replacement

- 1) Remove upper vacuum chamber per paragraph 5.2.1.
- 2) Remove both side guards (6-1-34 and 6-1-35). Drain all fluid from chamber.
- 3) Replace float ball (6-3-5) as follows:
  - a) Hold the top shoulder nipple of the linkage with an open end wrench or a pair of locking pliers (vise grips) to prevent its misalignment and to avoid bending the float valve linkage or breaking the seals.
  - b) Unthread float ball (6-3-5) and discard.
- 4) Replace float valve (6-2-4) as follows:
  - a) Remove float ball (6-3-5) and linkage in accordance with step (3) above.
  - b) Remove fittings from inlet and outlet of old float valve and install on new float valve. Remove and discard both the old float valve and valve gasket. Clean mounting surface on lower vacuum chamber.
  - c) Apply a thin film of gasket compound, such as Permatex #2 Non-hardening to both sides of new gasket (41) before installing. Also inspect both valve and face of mounting adapter for burrs, nicks, scratches, contaminant, or damage that may cause gasket to leak.
- 5) Install float valve (6-2-4), gasket (6-2-3), linkage and float ball (6-3-5) per steps (3) and (4) above.
- 6) Reinstall upper vacuum chamber per paragraph 5.2.1. Reinstall side guards.

## 5.5 Replacement of Discharge Filter Assembly and Coalescing Filter Assembly

<b>Table 5.5—Requirements</b>		
<b>ITEM</b>	<b>PART NUMBER</b>	<b>QTY</b>
<b>REPLACEMENT PARTS: (AS NEEDED)</b>		
Discharge Filter Head Assembly	PD00440F16ASSY	1
Discharge Filter Element	GC-00263F-168[G]	1
Coalescer Filter Assembly	PD-00946-SU80[G]B	1

### 5.5.1 Discharge Filter Head Assembly (entire head assembly) Replacement.

- 1) Remove spin-on element (6-12-2) and seal from head. Remove cable from differential pressure switch (6-12-5). Tag and disconnect wiring. Remove differential pressure switch and elbow.
- 2) Remove three bolts, holding the filter head (6-12-1) to the frame cover. Pull the filter head (6-12-1) down and away from the cover and frame. Remove the two hose fittings connected to the head.
- 3) Remove the boss seal adapter fittings from the old head and install on replacement head. Lubricate boss seals before installing with clean process fluid. Check the orientation of the two 1/2" street elbows. Elbows should point straight back through the frame. Use Loctite pipe sealant with Teflon (PST) #592 or equivalent on all NPT joints.
- 4) Reinstall replacement filter head on frame cover with three bolts. Reinstall differential pressure switch and reconnect wiring as tagged. Reinstall cable to switch.
- 5) Reinstall seal and spin on element (6-12-2) to head.

### 5.5.2 Coalescing Filter Assembly Replacement

- 1) Disconnect tube, from coalescer sump/bumper assembly, from bottom of filter bowl. Remove two bolts holding coalescer filter head (6-11-1) to side of frame cover and pull coalescing filter assembly down and away from cover.
- 2) Disconnect lines from coalescer inlet port. Replace all fittings on new assembly. Remove tube elbow from bottom of old bowl (6-11-2) and replace on new bowl.
- 3) Install replacement filter assembly onto cover. Reinstall tube from coalescer sump to bottom of filter bowl.



## 5.6 Removal and Replacement of Vacuum Pump, Discharge Pump, Main Drive Motor, Coalescer Pressure Switch, V-Belt, Sheaves, and Coupling

<b>Table 5.6—Requirements</b>		
<b>ITEM</b>	<b>PART NUMBER</b>	<b>QTY</b>
<b>REPLACEMENT PARTS: (AS NEEDED)</b>		
Vacuum Pump	PA-00440-D1936A	1
Discharge Pump	PA-00440-D1935[G]A	1
Main Drive Motor	AB-9500-D4137	1
Coalescer Pressure Switch	PA-00440-D2237H4A	1
V-Belt	PA-00440-D2154	1
Sheave, Motor	AB-A351-SHV25	1
Sheave, Discharge Pump	AB-A351-SHV26	1
Coupling Insert	AB-9500-D4132B	1
Coupling Half-Vac Pump	AB-9500-D4131B	1
Coupling Half-Motor	AB-9500-D4131C	1
<b>BULK MATERIALS:</b>		
Threadlock	Loctite 242 or equivalent	A/R
Pipe Sealant with Teflon	Loctite PST 592 or equivalent	A/R
<b>REQUIRED TOOLS:</b>		
Belt Tension Gauge (optional)	Commercially Available	1

### 5.6.1 Vacuum Pump Replacement

- 1) Remove two side guards (6-1-34 and 6-1-35). Disconnect both inlet and outlet lines, nylon tubing to coalescer pressure switch (6-4-8), oiler (6-1-37) and vacuum gauge (6-3-6).
- 2) Remove belt (6-4-7) from motor sheave (6-4-2) by loosening discharge pump (6-4-5) or working belt off sheave (6-4-2). Loosen motor sheave (6-4-2) and slide it towards the motor (6-4-4).
- 3) Loose set screws on both halves of coupling (6-2-5, 6-2 -6 and 6-2-7) connecting vacuum pump (6-4-6) to motor (6-4-4). Slide coupling towards the motor. Remove four hex nuts and lockwashers holding vacuum pump (6-4-6) to frame. Slide the coupling (6-2-5) off the vacuum pump (6-4-6) and remove the pump (6-4-6).
- 4) Remove fan covers from both ends of old pump and remove copper oiler lines and diaphragm. Install these on the replacement pump after removing its fan covers. Reinstall the fan covers on the new pump. Remove all plumbing from old pump, and reinstall on new pump. Be sure to maintain the same orientation of fittings.
- 5) Install coupling (6-2-5) on replacement pump. Position vacuum pump so that coupling aligns with drive motor shaft. Slide coupling half over motor shaft, align coupling, and secure vacuum pump in place.

- 6) Reinstall V-belt (6-4-7) on sheaves. Slide motor sheave (6-4-2) forward to align with discharge pump sheave (6-4-3). If discharge pump (6-4-5) was loosened to remove belt (6-4-7), reposition V-belt (6-4-7) over both sheaves (6-4-2 and 6-4-3) and re-tighten discharge pump nuts.
- 7) Re-align V-belt (6-4-7), sheaves (6-4-2 and 6-4-3), and coupling (6-2-5, 6-2-6 and 6-2-7) as needed and reinstall with their respective set screws. Apply Loctite 242 to set screws before installing.

### 5.6.2 Discharge Pump Replacement

- 1) Drain all oil from the unit.
- 2) Remove two side guards (6-1-34 and 6-1-35). Disconnect inlet and outlet hoses from the pump (6-4-5). Remove the two nuts which hold pump to frame. Remove V-belt (6-4-7) from the pump sheave (6-4-3). Withdraw pump from the purifier.
- 3) Note the orientation of all pipe fittings on old pump. Remove and reassemble them on the new pump. Be sure to maintain correct relief valve flow direction. Remove sheave (6-4-3) and Woodruff key (6-4-1) from old pump and reassemble them on the new pump.
- 4) Pour clean, new process oil into the pump suction port and turn shaft clockwise several times to ensure that pump gears are lubricated during initial startup.
- 5) Position replacement pump inside purifier. Position V-belt (6-4-7) over discharge pump sheave (6-4-3) before installing and tightening pump mounting hardware. Align sheave (6-4-3) and V-belt (6-4-7) as needed. Secure pump with mounting hardware.
- 6) Reconnect inlet and outlet hoses to pump. Reinstall two side guards (6-1-34 and 6-1-35).

#### NOTE

Prior to operation, remove upper chamber and fill chamber with clean process fluid to a height of 2 inches below the sealing lip. This is to insure that the discharge pump is well lubricated during startup.

### 5.6.3 Main Drive Motor Replacement

#### WARNING

**INSPECT REPLACEMENT MAIN DRIVE MOTOR [1] CAREFULLY FOR INFORMATION ON THE NAMEPLATE INDICATING THAT THE MOTOR HAS NO INTERNAL OVERLOAD PROTECTION. ANY MOTOR USED TO DRIVE THE PUMPS MUST BE WITHOUT INTERNAL OVERLOAD PROTECTION. USE OF A MOTOR WITH THERMAL OR OTHER TYPE OF INTERNAL OVERLOAD PROTECTION MAY RESULT IN AUTOMATIC RESTARTING DURING SERVICING AND CAUSE SERIOUS INJURY. USE ONLY MOTORS SUPPLIED BY PALL CORPORATION UNDER P/N AB-9500-D4137.**

- 1) Remove two side guards (6-1-34 and 6-1-35).
- 2) Remove V-belt (6-4-7) from motor sheave (6-4-2) by either loosening discharge pump (6-4-5) or by working the belt off of one sheave.
- 3) Remove four hex nuts, lockwashers, and washers holding motor (6-4-4) to frame. Loosen set screws on coupling (6-2-5, 6-2-6 and 6-2-7) and slide coupling off motor shaft.

- 4) Remove cable. Tag and disconnect wiring to motor (6-4-4). Remove motor (6-4-4) from frame. Remove sheave (6-4-2) from old motor and reassemble it on the new motor.
- 5) Check the new motor to be sure it has no thermal or other type of internal overload protection. See WARNING, above. Check that replacement motor is wired for 120 VAC (low voltage connections). Remove shaft key. Connect motor to 120 VAC, 60 Hz, 15 amperes grounded power and check for correct shaft rotation (clockwise, facing shaft end of motor). If all these are in order, proceed. If not, rewire as required.
- 6) Replace shaft key. Position replacement motor (6-4-4) with attached sheave (6-4-2) inside purifier frame. Reconnect motor wiring as tagged and reinstall cable.
- 7) Reposition V-belt (6-4-7) over motor sheave (6-4-2). Align motor shaft with coupling (6-2-5) left on vacuum pump shaft and slide motor half of coupling (6-2-6) over motor shaft. Tighten coupling setscrews.
- 8) Secure motor (6-4-4) to frame with four hex nuts, flat washers, and lockwashers.
- 9) If discharge pump (6-4-5) was loosened to remove V-belt (6-4-7), retighten discharge pump mounting hardware. Ensure that V-belt (6-4-7) engages both sheave (6-4-3) on pump and sheave (6-4-2) on drive motor. Realign V-belt or sheaves as needed.
- 10) Reinstall two side guards (6-1-34 and 6-1-35).

#### 5.6.4 Coalescer Pressure Switch Replacement

- 1) Remove two side guards (6-1-34 and 6-1-35).
- 2) Disconnect tube running from pressure switch (6-4-8) to the vacuum pump (6-4-6) outlet. Remove cable. Tag and disconnect pressure switch wires per terminal connections.
- 3) Remove coalescer pressure switch (6-4-8) from frame.
- 4) Inspect replacement coalescer pressure switch for a tag packed with the switch, stating that it has been calibrated and tested.
- 5) Remove cord grip and tube elbow from old switch and reinstall on new switch.
- 6) Install replacement switch to frame. Orient same removed switch.
- 7) Reconnect switch wiring as tagged. Reinstall cable.
- 8) Reinstall two side guards (6-1-34 and 6-1-35).

#### 5.6.5 V-Belt Replacement

- 1) Disconnect and remove the old V-belt (6-4-7) from sheaves (6-4-2 and 6-4-3) by loosening tension at discharge pump (6-4-5) or by working the belt off one sheave while turning drive by hand.
- 2) Note orientation of V-belt links. Correct orientation of belt is such that when turning the drive in the direction of rotation, the bottom tapered link enters the sheaves last. Measure out sufficient length of new belting to allow for proper initial tension while still allowing enough discharge pump travel to compensate for approximately 10% stretch due to belt break in. Check sheaves (6-4-2 and 6-4-3) for oil and damage. Clean off oil or replace sheaves (6-4-2 and 6-4-3) if required.
- 3) Install new belt. Check for correct orientation.

- 4) Align and tighten drive as follows:
  - a) If using a belt tension gauge (optional): Initial belt tension should be 4.8 pounds (21.4 N) as measured with belt tension gauge at midspan to produce deflection of 0.16 inch (4.064 mm).
  - b) Start up purifier and check belt for looseness by closing outlet valve. There should be no slippage. Open outlet valve and allow unit to run for several hours.
  - c) After several hours of operation, recheck tension and adjust. Belt tension after break in should be between 2.4 and 3.6 pounds (1.09 to 1.63 kg) as measured with belt tension gauge at midspan, to produce 0.16 inch (4.064 mm) of deflection. Recheck belt tension frequently during first 50 operating hours after installing a new belt.

#### 5.6.6 Discharge Pump Sheave Replacement

- 1) Remove V-belt (6-4-7) from sheaves (6-4-2 and 6-4-3) per paragraph 5.6.5, above.
- 2) Insert a 5/32" long arm hex key (Allen wrench) and remove the sheave set screw.
- 3) Remove the sheave (6-4-3) from the discharge pump shaft. Use a wheel or gear puller if required. Take care not to lose the Woodruff key (6-4-1).
- 4) Apply Loctite 242 or equivalent to sheave set screw (if old set screw is to be reused, remove cured Threadlock and reapply new Loctite 242).
- 5) Reassemble replacement sheave (6-4-3) and Woodruff key (6-4-1) on discharge pump as marked. Reinstall set screw with a 5/32" hex key.
- 6) Reinstall V-belt (6-4-7) per preceding paragraphs. Align V-belt (6-4-7) and sheaves (6-4-2 and 6-4-3) as needed.

#### 5.6.7 Motor Sheave Replacement

- 1) Remove V-belt (6-4-7) from sheaves per paragraph 5.6.5.
- 2) Remove set screws on sheave and on both halves of coupling (6-2-5, 6-2-6 and 6-2-7). Remove four hex nuts, lockwashers, and washers, holding motor (6-4-4) to frame.
- 3) Separate coupling halves (6-2-5 and 6-2-6), remove insert (6-2-7), and remove motor (6-4-4). Take care not to force the shaft key all the way back towards the motor as this may cause the key to ride up in the keyway and bind the sheave.
- 4) Slide the coupling half (6-2-6) and motor sheave (6-4-2) off the motor shaft. Use a puller if required.
- 5) Install replacement motor sheave on drive motor shaft. Reassemble coupling insert (6-2-7) and vacuum pump coupling half (6-4-3). Reposition motor to align motor shaft with coupling half (6-2-5) left on vacuum pump shaft. Slip V-belt (6-4-7) over motor sheave (6-4-7) and discharge pump sheave (6-4-7). Slide motor half of coupling over motor shaft and reinstall motor mounting hardware.
- 6) Align sheaves (6-4-2 and 6-4-3) and V-belt (6-4-7) as needed before securing with set screws. If set screws are to be reused, remove cured threadlock and reapply Loctite 242 before reinstalling. Secure sheaves (6-4-2 and 6-4-3) and coupling halves (6-2-5 and 6-2-7) with their respective set screws.

### 5.6.8 Coupling Replacement

- 1) Remove V -belt (6-4-7) from motor sheave (6-4-2). Remove hex nuts, lockwashers and flat washers holding drive motor (6-4-4) and vacuum pump (6-4-6) to frame.
- 2) Loosen set screws on both halves of coupling (6-2-5 and 6-2-6). Separate coupling halves (6-2-5 and 6-2-6) until insert (6-2-7) can be removed, and remove coupling (6-2-5 and 6-2-6).
- 3) Push motor (6-44) out of the way and remove coupling halves (6-2-5 and 6-2-6) from vacuum pump (6-4-6) and motor shafts. Use a puller if required.
- 4) Slip replacement coupling halves onto vacuum pump and motor shafts. Reassemble insert. Reassemble motor (6-4-4) and vacuum pump (6-4-6) to frame. Align shafts. Tighten motor and vac pump. Reinstall V-belt (6-4-7) on motor sheave (6-4-2).
- 5) Apply Loctite 242 on coupling set screws. If set screws are reused, remove cured threadlock before reapplying Loctite.

## 6.0 ILLUSTRATED PARTS LIST

### 6.1 Introduction

This parts list describes and illustrates the maintenance parts applicable to the portable fluid purifier.

### 6.2 Explanation of Columns Used in the Parts List

#### 6.2.1 Figure and item Number Column

The figure and item numbers key the parts breakdown to the applicable illustration. The number preceding the dash is the figure number of the illustration. A dash preceding the item number indicates that this item is not illustrated.

#### 6.2.2 Part Number Column

This column contains the manufacturers or standard (MS, AN, or NAS) part number.

#### 6.2.3 Description Column

This column identifies the listed parts by noun name followed by modifiers when applicable.

#### 6.2.4 Quantity Column

This column indicates the quantity of parts required for the assembly or subassembly in which that part appears. In the case of components of assemblies, the quantities listed indicate the number of parts used in one assembly. The letters AR indicate quantity as required.

### 6.3 Seal Compatibility

To assure seal compatibility with fluid to be processed, refer to Table 6.3.1, below.

<b>Table 6.3.1 Seal Compatibility Table</b>		
<b>Code [G]<sup>2</sup></b>	<b>Seal Material</b>	<b>Fluid Serviced</b>
H	Buna N	Petroleum
Z	Viton	Petroleum, Specified Synthetics
J	EPR	Type IV Phosphate Esters (Skydrol 500)

Where uniform O-rings are identified by uniform size, specify o-ring compound per Table B, to assure compatibility with fluid being processed.

<b>Table 6.3.2: O-Ring Compatibility Table</b>		
<b>P/N O-Ring Compound</b>	<b>Seal Material</b>	<b>Fluid Serviced</b>
MS28775-	Buna N	Petroleum
M83248/1-	Viton	Petroleum, Specified Synthetics
NAS1611-	EPR	Type IV Phosphate Esters (Skydrol 500)

EXAMPLE: MS28775-327 indicates "uniform size -327" O-ring with Buna N seals for petroleum base fluid being serviced.

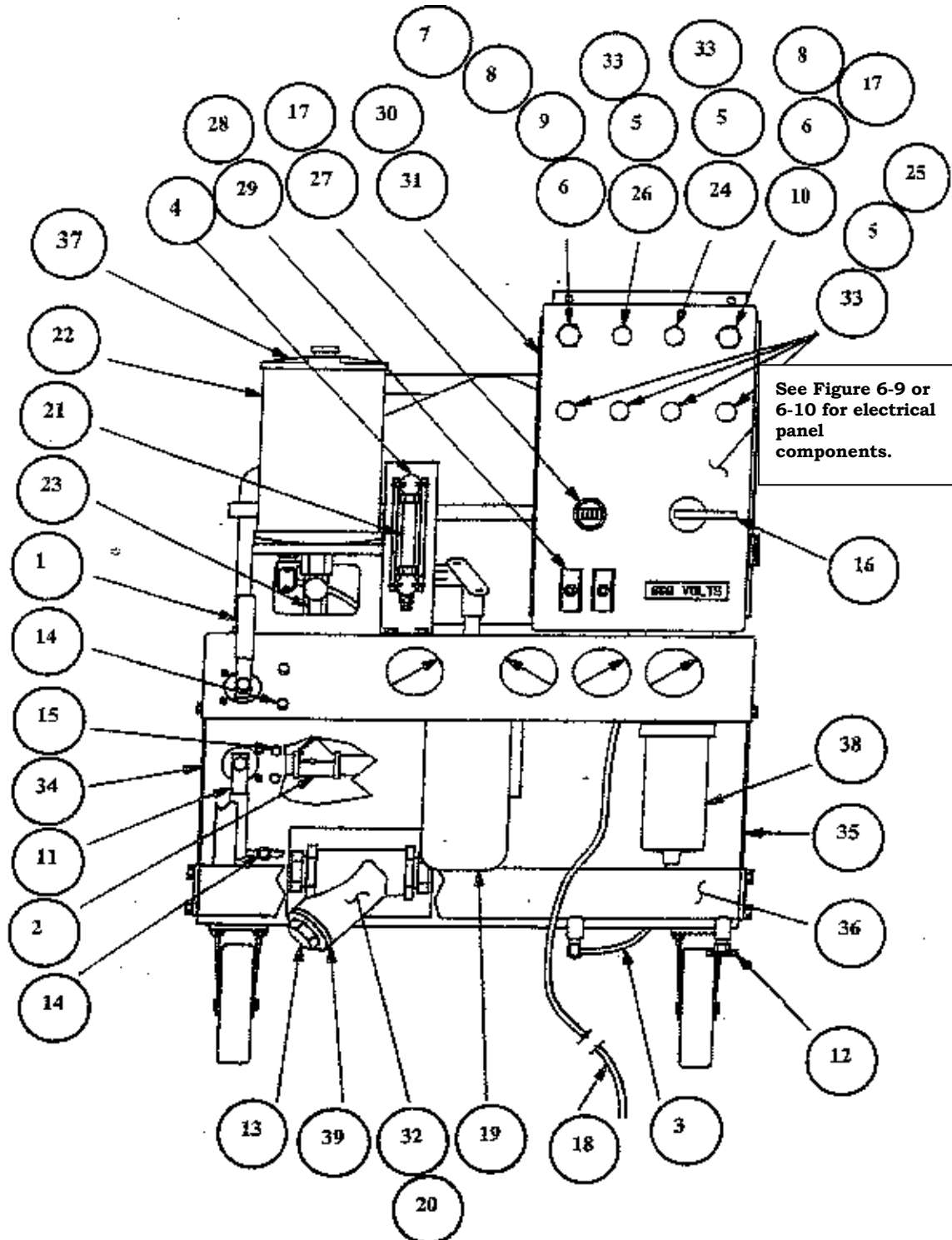

**Figure 6-1. Portable Hydraulic Purifier**

**Table 6.1.1: Portable Hydraulic Purifier Parts Listing**

<b>Item Number</b>	<b>Part Number</b>	<b>Description</b>	<b>Quantity</b>
6-1-1	AA-9500-D1387	Valve, Ball, 1"	1
6-1-2	AA-9500-D1837	Discharge Check Valve, 1/2"	1
6-1-3	AA-9500-D2272	Tubing, 3/8"	A/R
6-1-4	AA-9500-D2314	Sight Gauge, Level	1
6-1-5	AA-9500-D4125	Lamp, Indicator 120V	6
6-1-6	AA-9500-D4127	Operator Block, NEMA 4x Push Button	2
6-1-7	AA-9500-D4128	Contact Block, Green	A/R
6-1-8	AA-9500-D4128B	Contact Block, Red	A/R
6-1-9	AA-9500-D4129	Operator Head, Black	1
6-1-10	AA-9500-D4130	Operator Head, Red Mushroom	1
6-1-11	AA-9500-D1952	Valve, Ball, 3/4"	1
6-1-12	AA-9500-D585	Valve, Drain, 1/4"	1
6-1-13	AB-A351-PLG6D	Plug, Pipe, 3/4" Brass	1
6-1-14	AB-A351-UBLT16	U-Bolt, 1" Pipe, 1/4-20	3
6-1-15	AB-A351-UBLT12	U-Bolt, 3/4" Pipe, 114-20	5
6-1-16	AB-9500-D4116	Handle, Disconnect	1
6-1-17	AB-9500-D4126	Hourmeter (60 Hz only)	1
	AB-9500-D4126B	Hourmeter (50 Hz only)	
6-1-18	AC-A351-SCRH0604	12/3 SO Cable; 230 & 460V	15'
		12/3 SO Cable; 120V	35'
6-1-19	GD-00273-168[G]	Assembly, Filter (also see Fig. 6-12 for parts)	1
6-1-20	PA-00440-1967A	Element, Y-Strainer	1
6-1-21	PA-00440-D23141 A	Level Sight Gauge, Spare Glass	1
6-1-22	PA-00440-D32831A	Reservoir, Spare Glass	1
6-1-23	PA-00440-D32832A	Needle Valve, Spare Glass	1
6-1-24	PB-00440-LENS02	Lens, Green, NEMA 4x	1
6-1-25	PB-00440-LENS03	Lens, Red, NEMA 4x	4
6-1-26	PB-00440-LENS04	Lens, Amber, NEMA 4x	1



<b>Table 6.1.1: Portable Hydraulic Purifier Parts Listing (continued)</b>			
<b>Item Number</b>	<b>Part Number</b>	<b>Description</b>	<b>Quantity</b>
6-1-27	PB-00440-W1D3	Gasket, Hourmeter	1
6-1-28	PB-00440-1EAD70	Guard, Toggle Switch - for Seal Code H	2
	PB-00440-1EAD70P	Guard, Toggle Switch - for Seal Code J	
	PB-00440-1EAD70	Guard, Toggle Switch - for Seal Code Z	
6-1-29	PB-00721-1CB12C	Breaker, Circuit, 12A	2
6-1-30	PB-00946-1EAD92	Terminal Strip, 10 position	1
6-1-31	PB-00946-1EAD93	Terminal Strip, 15 position	1
6-1-32	PC-00440-D1967M	Y-Strainer	1
6-1-33	PC-00721-1EAD229	Operator Block, NEMA 4x Lamp	6
6-1-34	PD-00440-D12B	Guard, Valve Side	1
6-1-35	PD-00440-D14B	Guard, Valve Pump Side	1
6-1-36	PD-00440-D51B	Sump/Bump, Coalescer	1
6-1-37	PD-00946-DS3283A	Assembly, Oiler, Spare	1
6-1-38	PD-00946-SU80[G]B	Assembly, Filter, Coalescing (also see Figure	1
6-1-39	Uniform size—132	O-Ring (see Table 6-1)	1

<b>Table 6.1.2: O-Ring Compatibility Table</b>		
<b>P/N O-Ring Compound</b>	<b>Seal Material</b>	<b>Fluid Serviced</b>
MS28775-	Buna N	Petroleum
M83248/1-	Viton	Petroleum, Specified Synthetics
NAS1611-	EPR	Type IV Phosphate Esters (Skydrol 500)

EXAMPLE: MS28775-132 indicates "Uniform Size—132" O-Ring with Buna-N Seals for petroleum base fluid serviced.

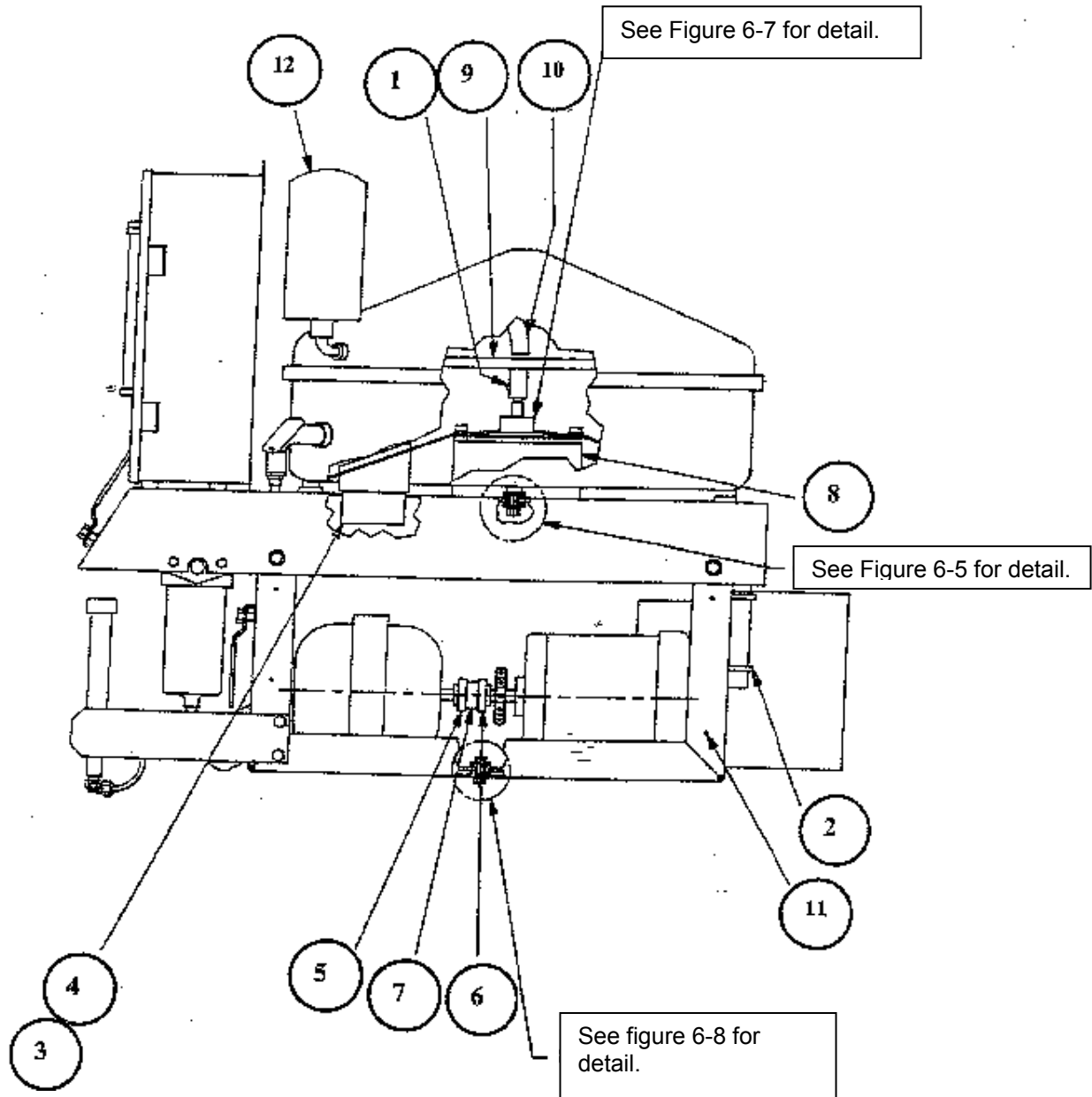

**Figure 6-2. Side Layout of the Portable Hydraulic Purifier**

**Table 6.2.1: Side Layout of the Portable Hydraulic Purifier Parts Listing**

<b>Item Number</b>	<b>Part Number</b>	<b>Description</b>	<b>Quantity</b>
6-2-1	AA-9500-D2115	Set Screw, ¼-2-Nylon Tip	1
6-2-2	AB-A351-UBLT12	U-Bolt, ¾" Pipe, ¼-20	5
6-2-3	AB-A351-12D92H	Gasket, Valve	1
6-2-4	AB-A352-8D999H	Assembly, Valve, Float	1
6-2-5	AB-9500-D4131B	Coupling Half, Vacuum Pump	1
6-2-6	AB-9500-D4131C	Coupling Half, Motor	1
6-2-7	AB-9500-D4132B	Coupling Insert	1
6-2-8	PA-00440-D4136A	Motor, Disc	1
6-2-9	PA-00440-VCD4A	Disc	1
6-2-10	PB-00440-1D23A	Assembly, Feed Tube/Fitting	1
6-2-11	PE004401DFA11	Frame, Lower	1
6-2-12	<i>See Purifier ID Name Plate</i>	Filter, Breather	1

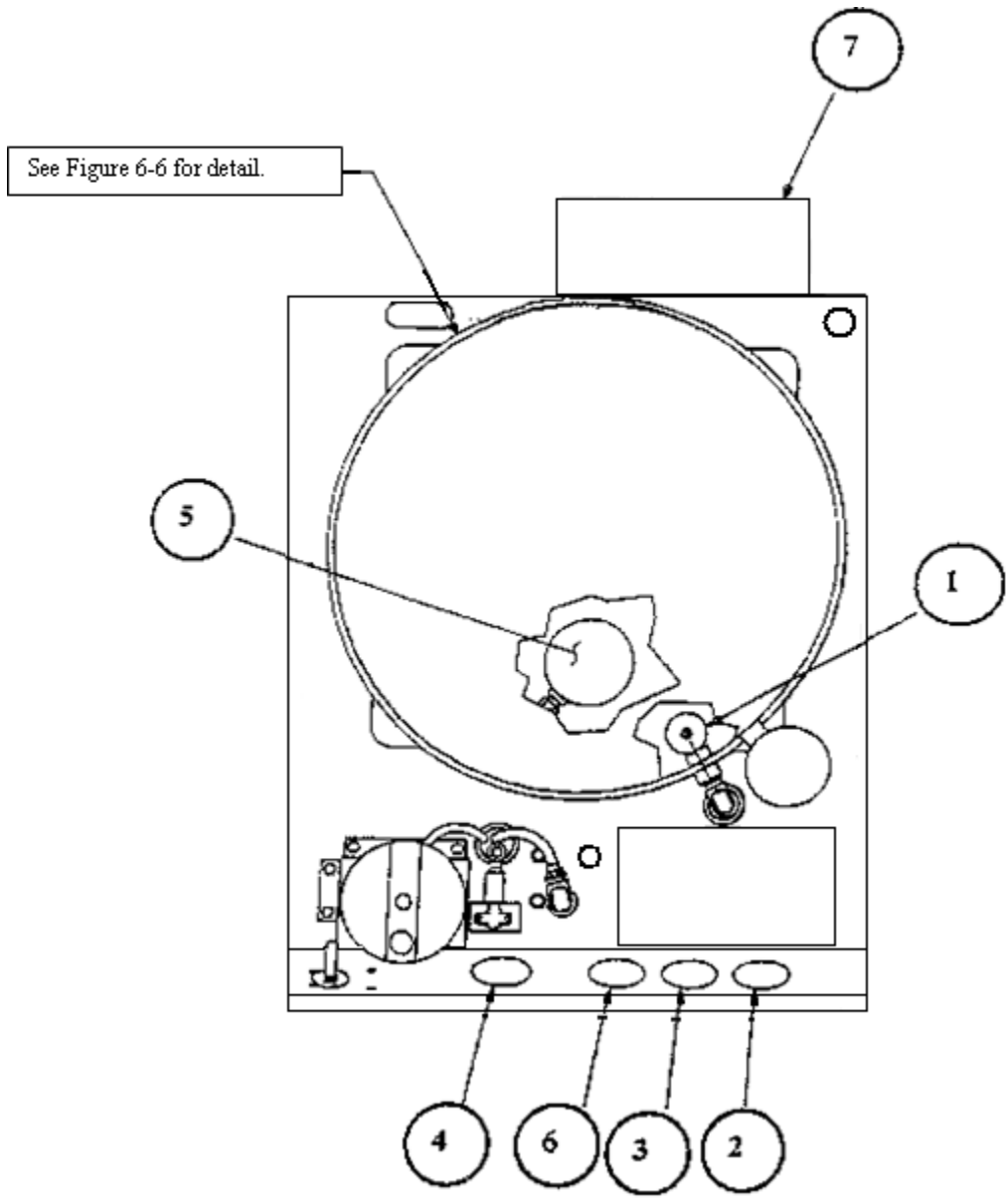

**Figure 6-3: Top-Half Layout of the Portable Hydraulic Purifier**

<b>Table 6.3.3: Top-Half Layout of the Portable Hydraulic Purifier Parts Listing</b>			
<b>Item Number</b>	<b>Part Number</b>	<b>Description</b>	<b>Quantity</b>
6-3-1	AA-9500-D1944	Float Switch	1
6-3-2	AB-9500-D4122	Gauge, Pressure, 0-160 PSIG	1
6-3-3	AB-9500-D4120	Gauge, Compound, 30-0-30	1
6-3-4	AA-9500-D4119	Gauge, Temperature, 40-60°F	1
6-3-5	AA-9500-D1968	Ball, Spherical, 4"	1
6-3-6	AB-9500-D4121	Gauge, Vacuum, 0-30" Hg	1
6-3-7	PB-00440-D2574BB <sup>1</sup> PB-00440-D2574DB <sup>2</sup> PB-00440-1EA8A <sup>3</sup>	Assembly, Transformer  Assembly, Soft Start Assembly, Transformer	1

<sup>1</sup> For 230 & 460 volt units only.

<sup>2</sup> For 575 Volt units only.

<sup>3</sup> For 120 volt units only.

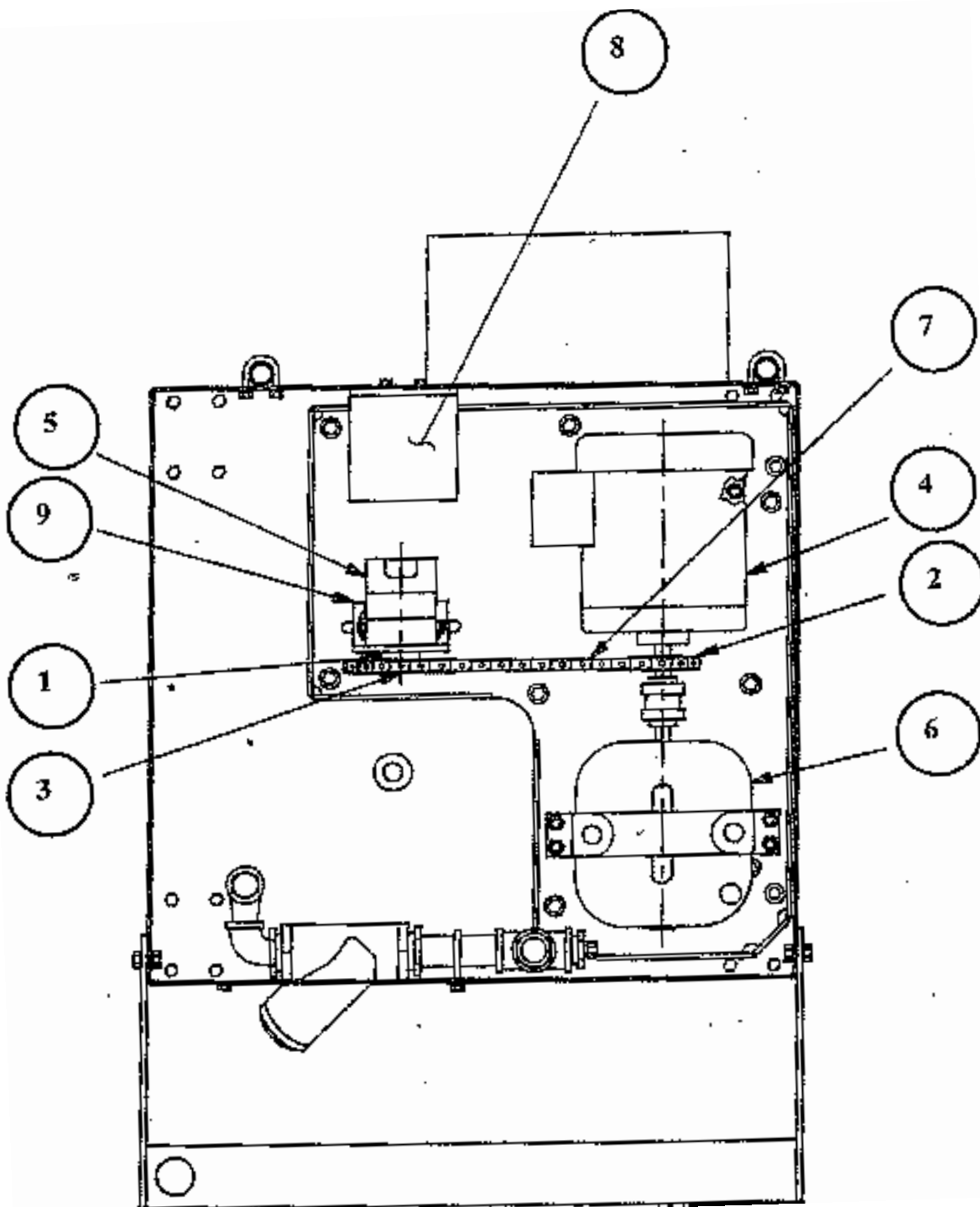
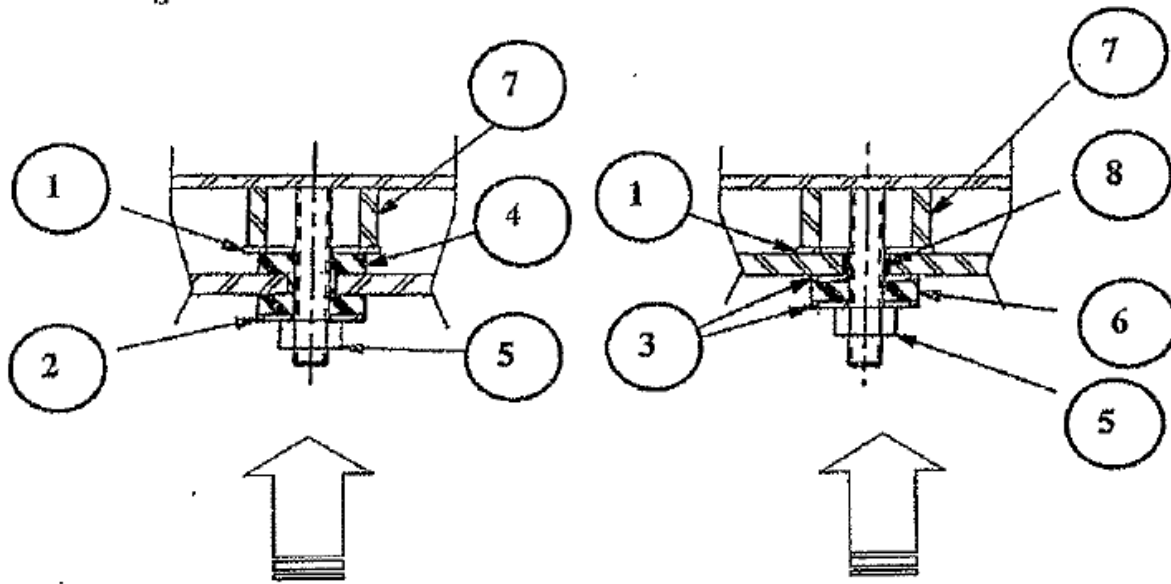

**Figure 6-4: Bottom-Half Layout of the Portable Hydraulic Purifier**

**Table 6.4.1: Bottom-Half Layout of the Portable Hydraulic Purifier Parts Listing**

<b>Item Number</b>	<b>Part Number</b>	<b>Description</b>	<b>Quantity</b>
6-4-1	AA-9500-D1965	Woodruff Key, #404	1
6-4-2	AB-A351-SHV25	Sheave, Motor, 5/8" Bore	1
6-4-3	AB-A351-SHV26 AB-A351SHV28	Sheave, Discharge Pump, 1/2" Bore (60 Hz only) Sheave, Discharge Pump, 1/2" Bore (50 Hz only)	1
6-4-4	AB-9500-D4137	Motor, Main	1
6-4-5	PA-00440-D1935HA PA-00440-D1935JA PA-00440-D1935Z	Pump, Discharge – for Seal Code H Pump, Discharge – for Seal Code J Pump, Discharge – for Seal Code Z	1
6-4-6	PA-00440-D1936A	Pump, Vacuum	1
6-4-7	PA-00440-D2154	Belt, V-Link	1
6-4-8	PA-00440D2237H4A	Switch, Pressure, Coalescer, Preset	1
6-4-9	PA-00440-1D60A	Bracket, Pump Mounting	1

**NOTE:** Tighten nut only until first contact with rubber.



Lower Chamber to Framer Cover mounting Detail, 4 places applicable, for Part Number: PE-01078[GG]H[GG][GG]

Lower Chamber to Framer Cover Mounting Detail, 4 places applicable, for Part Number: PE-01078[GG]J[GG][GG] PE-01078[GG]Z[GG][GG]

**Figure 6-5: Lower Chamber and Frame Cover Mounting Detail**

**Table 6.5.1: Lower Chamber and Frame Cover Mounting Parts Listing**

Item Number	Part Number	Description	Quantity
6-5-1	MS2544-6A	Washer, Flat	4
6-5-2	MS27183-15 <sup>4</sup>	Washer, Flat	4
6-5-3	MS27183-17 <sup>5</sup>	Washer, Flat	8
6-5-4	MS35489-42 <sup>4</sup>	Grommet	4
6-5-5	MS51922-17	Lock Nut, 3/8 – 16	A/R
6-5-6	PB-00440-D500J <sup>5</sup> PB-00440-D500Z <sup>5</sup>	Washer, Rubber – for Seal Code J Washer, Rubber – for Seal Code Z	4
6-5-7	PB-00440-D547B	Spacer, Vacuum Chamber	4
6-5-8	Uniform Size – 110 <sup>5</sup>	O-Ring	4

<sup>4</sup> For units with Seal Code H only.

<sup>5</sup> For units with Seal Code J or Z.



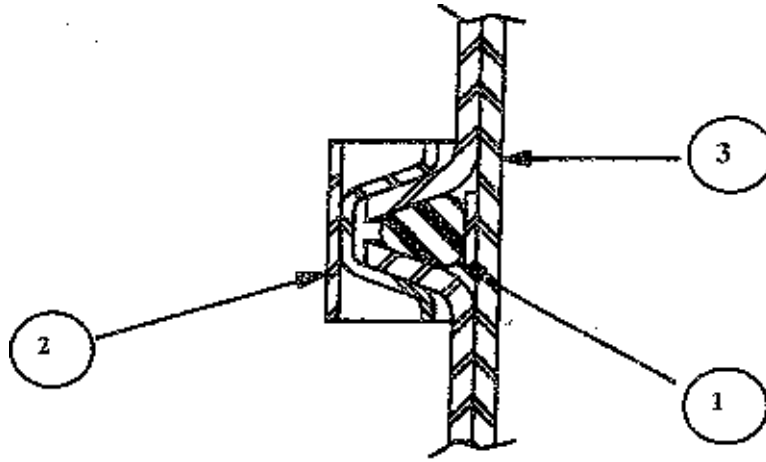

**Figure 6-6. V-Band Clamp and Vacuum Chamber Mounting Detail**

<b>Table 6.6.1: V-Band Clamp and Vacuum Chamber Mounting Parts Listing</b>			
<b>Item Number</b>	<b>Part Number</b>	<b>Description</b>	<b>Quantity</b>
6-6-1	AA-9500-D1939H AA-9500-D1939J AA-9500-D1939Z	O-Ring, -472 – for Seal Code H O-Ring, -472 – for Seal Code J O-Ring, -472 – for Seal Code Z	1
6-6-2	AA-9500-D1940	V-Band Clamp	1
6-6-3	PA-00440-VCD3 PA-00440-VCD3P PA-00440-VCD3P	Retainer, Vacuum Seal – for Seal Code H Retainer, Vacuum Seal – for Seal Code J Retainer, Vacuum Seal – for Seal Code Z	1

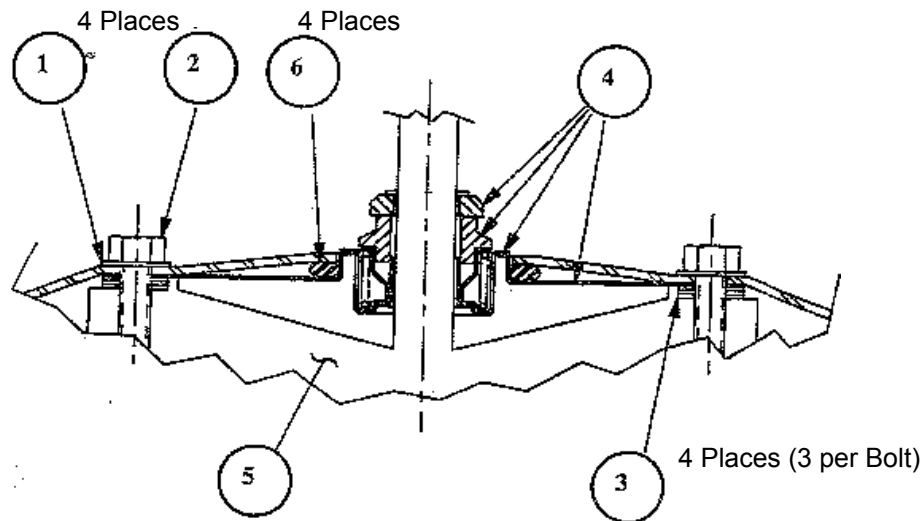
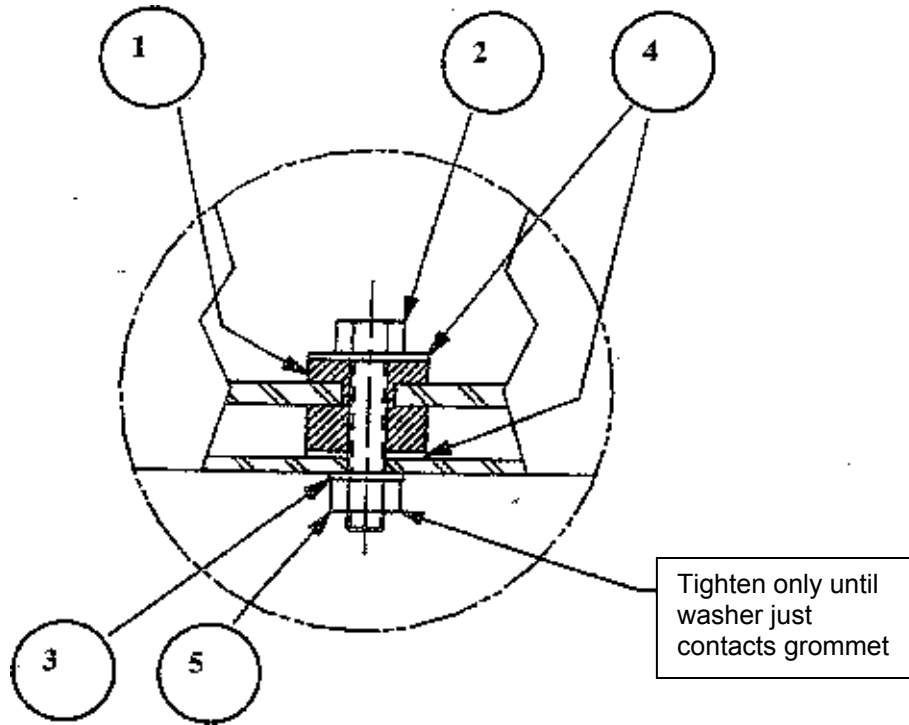

**Figure 6-7: Disc Motor and Lower Chamber Mounting Detail**
**Table 6.7.1: Disc Motor and Lower Chamber Mounting Parts Listing**

Item Number	Part Number	Description	Quantity
6-7-1	AA-9500-D1985H NAS15236E NAS15236P	Sealing, Washer-for Seal Code H Sealing, Washer-for Seal Code Z Sealing, Washer-for Seal Code J	4
6-7-2	AA-9500-D846	Bolt, Hex, 3/8-16x1	AR
6-7-3	AN960616	Washer, Flat	12
6-7-4	P A-00440-DVC5HA P A-00440-DVC5JA P A-00440-DVC5ZA	Assembly, Mechanical Seal/Plate -for Seal Code H Assembly, Mechanical Seal/Plate -for Seal Code J Assembly, Mechanical Seal/Plate -for Seal Code Z	1
6-7-5	PC-00440-D1SCMTRH PC-00440-D1SCMTRJ PC-00440-D1SCMTRZ	Assembly, Mechanical Seal/Plate -for Seal Code H Assembly, Mechanical Seal/Plate -for Seal Code J Assembly, Mechanical Seal/Plate -for Seal Code Z	1
6-7-6	Uniform Size -327	O-Ring (see Table 6-7)	1

**Table 6.7.2: O-Ring Compatibility Table**

P/N O-Ring Compound	Seal Material	Fluid Serviced
MS28775-	Buna N	Petroleum
M832481-	Viton	Petroleum, Specified Synthetics
NAS1611-	EPR	Type IV Phosphate Esters (Skydrol 500)

Example: MS28775-327 indicates “uniform size -327” O-Ring with Buna N seals for petroleum base fluid being serviced.



**Figure 6-8. Discharge/Vacuum Pump Assembly and Lower Frame Mounting Detail**

<b>Table 6.8.1: Discharge/Vacuum Pump Assembly and Lower Frame Mounting Parts Listing</b>			
<b>Item Number</b>	<b>Part Number</b>	<b>Description</b>	<b>Quantity</b>
6-8-1	AA-9500-D2866	Grommet	8
6-8-2	AC-A351-SCRH1112	Bolt, hex, 5/16" – 18 x 1 – 1/2"	8
6-8-3	AN960-516	Washer, Flat, 5/16"	8
6-8-4	MS25440-5	Washer, Flat	16
6-8-5	MS51922-9	Lock Nut, 5/16" – 18	A/R

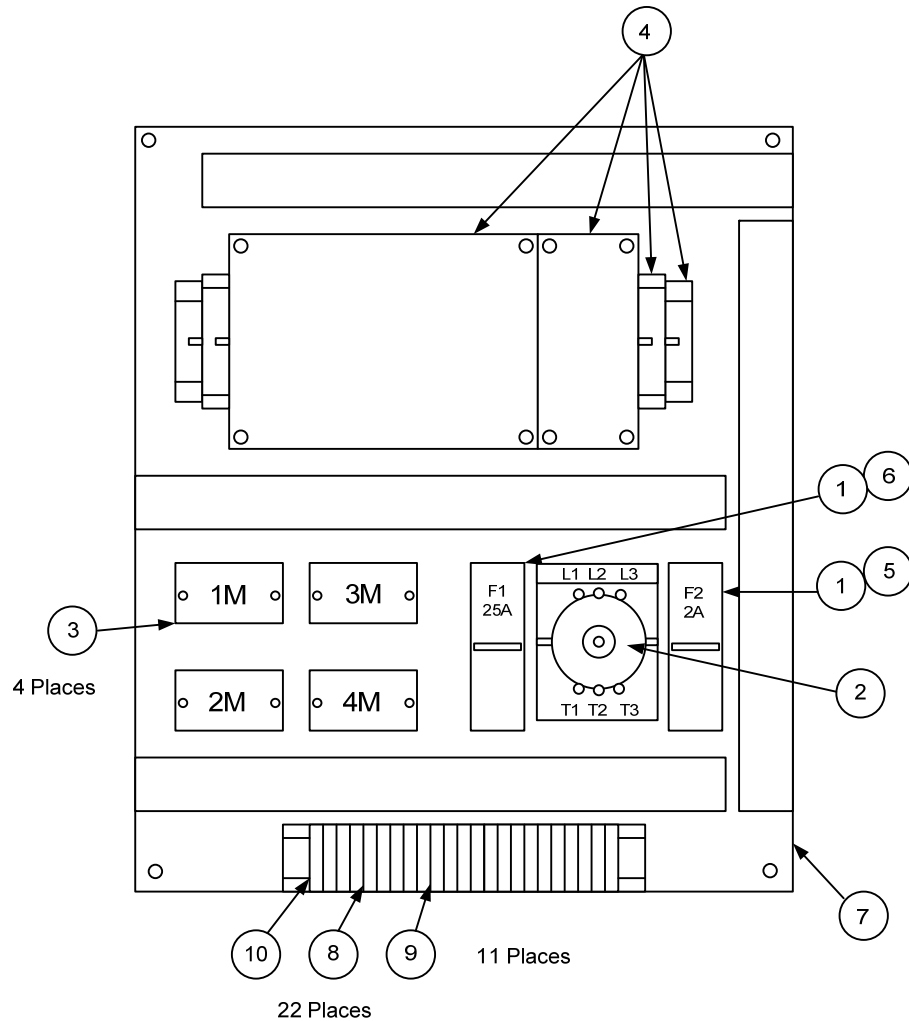

**Figure 6-9: Electrical Panel Components Layout for Units with PLC (120 Volts)**

<b>Table 6.9.1: Electrical Panel Components Layout for Units with PLC (120 Volts) Parts Listing</b>			
<b>Item Number</b>	<b>Part Number</b>	<b>Description</b>	<b>Quantity</b>
6-9-1	AB-9500-D2896	Fuse Holder	2
6-9-2	AB-9500-D4115	Disconnect Switch	1
6-9-3	AB-9500-D4114	Relay, Power	4
6-9-4	PA-00440-D4133P12A	PLC, Assembly, Spare	1
6-9-5	AB-9500-D4182AK	Fuse, 2A	1
6-9-6	AB-9500-D4182BH	Fuse, 25A	1
6-9-7	PD-00440-1EAD120	Panel	1
6-9-8	PB-00946-1EAD86	Terminal Block	A/R
6-9-9	PB-00946-1EAD88	Connector	A/R
6-9-10	PB-00946-1EAD89	End Plate	2

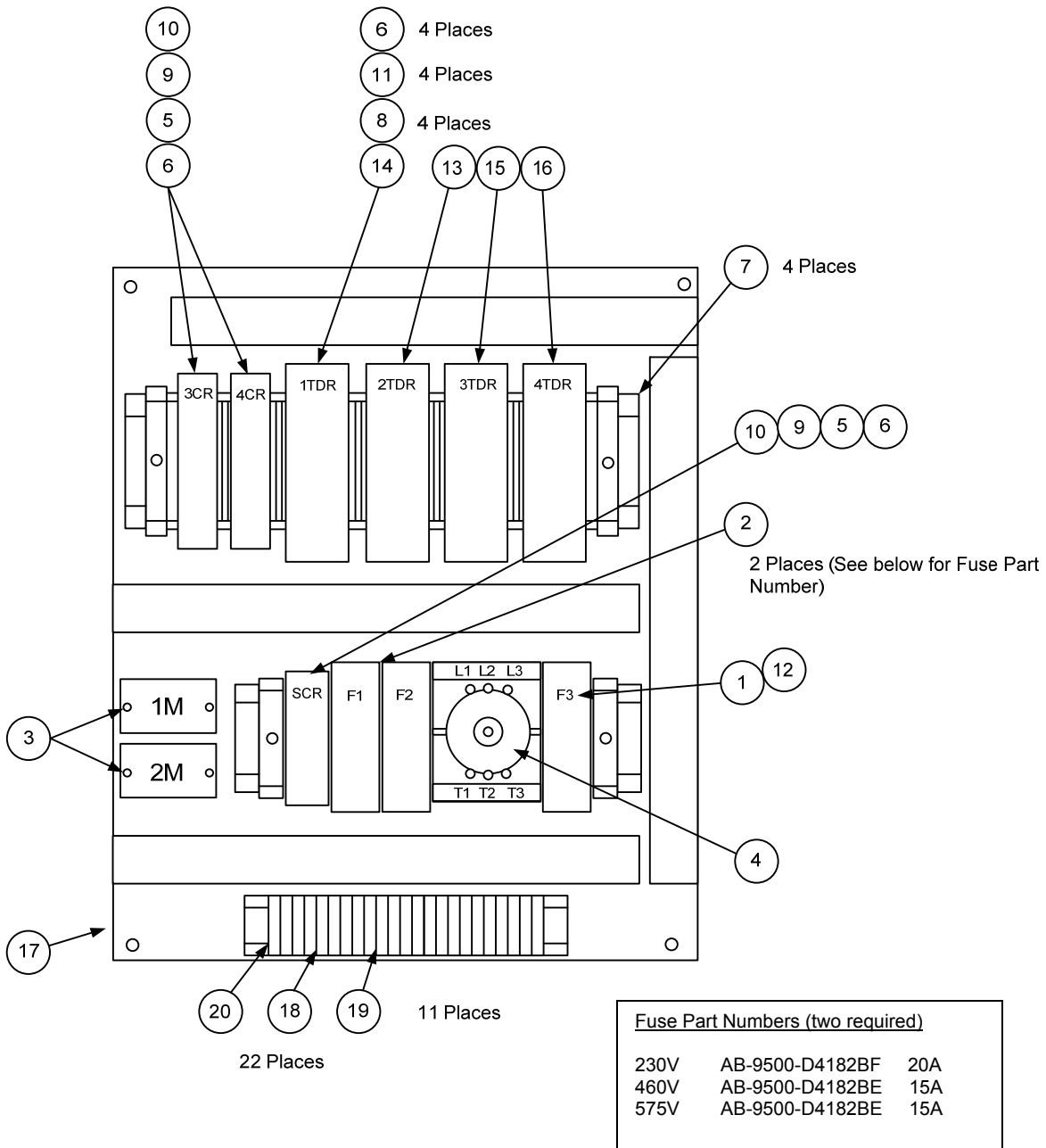

**Figure 6-10a. Electrical Panel Components Layout for Units with Relay Logic  
(230, 460 and 575 Volts)  
(For unit built before 01/01/2013)**

<b>Table 6.10.1a: Electrical Panel Components Layout for Units with Relay Logic Parts Listing</b>			
<b>Item Number</b>	<b>Part Number</b>	<b>Description</b>	<b>Quantity</b>
6-10a -1 <sup>6</sup>	AB-9500-D2896	Fuse Holder	1
6-10a -2	AB-9500-D2896B	Fuse Holder	2
6-10a -3	AB-9500-D4114	Relay, Power	2
6-10a -4	AB-9500-D4115	Disconnect Switch	1
6-10a -5	AA-9500-D4138C	Spring, Hold Down	A/R
6-10a -6	AA-9500-D4138D	Clip, Hold Down	A/R
6-10a -7	AA-9500-D4138E	End Stop	2
6-10a -8	AA-9500-D4138J	Spring, Hold Down Relay	4
6-10a -9	AB-9500-D4139B	Socket, Relay – DIN Rail	A/R
6-10a -10	AB-9500-D4140	Relay Control DPDT, 3A	2
6-10a -11	AA-9500-D4145	Socket Time Delay Relay	4
6-10a -12	AB-9500-D4182AK	Fuse, 2A	1
6-10a -13	PB-00440-D414105A	Time Delay Relay, Spare	A/R
6-10a -14	PB-00440-D41410A	Time Delay Relay, Spare	A/R
6-10a -15	PB-00440-D41432MA	Time Delay Relay, Spare	A/R
6-10a -16	PB-00440-D414405A	Time Delay Relay, Spare	A/R
6-10a -17	PD-00440-1EAD230	Panel	1
6-10a -18	PB-00946-1EAD86	Terminal Block	A/R
6-10a -19	PB-00946-1EAD88	Connector	A/R
6-10a -20	PB-00946-1EAD89	End Plate	2

<sup>6</sup> This fuse holder may locate at the right side of the AB-9500-D4115 Disconnect Switch (6-10-4)  
The use or disclosure of this data is subject to the restrictions on the title page of this document.  
Export controlled by EAR

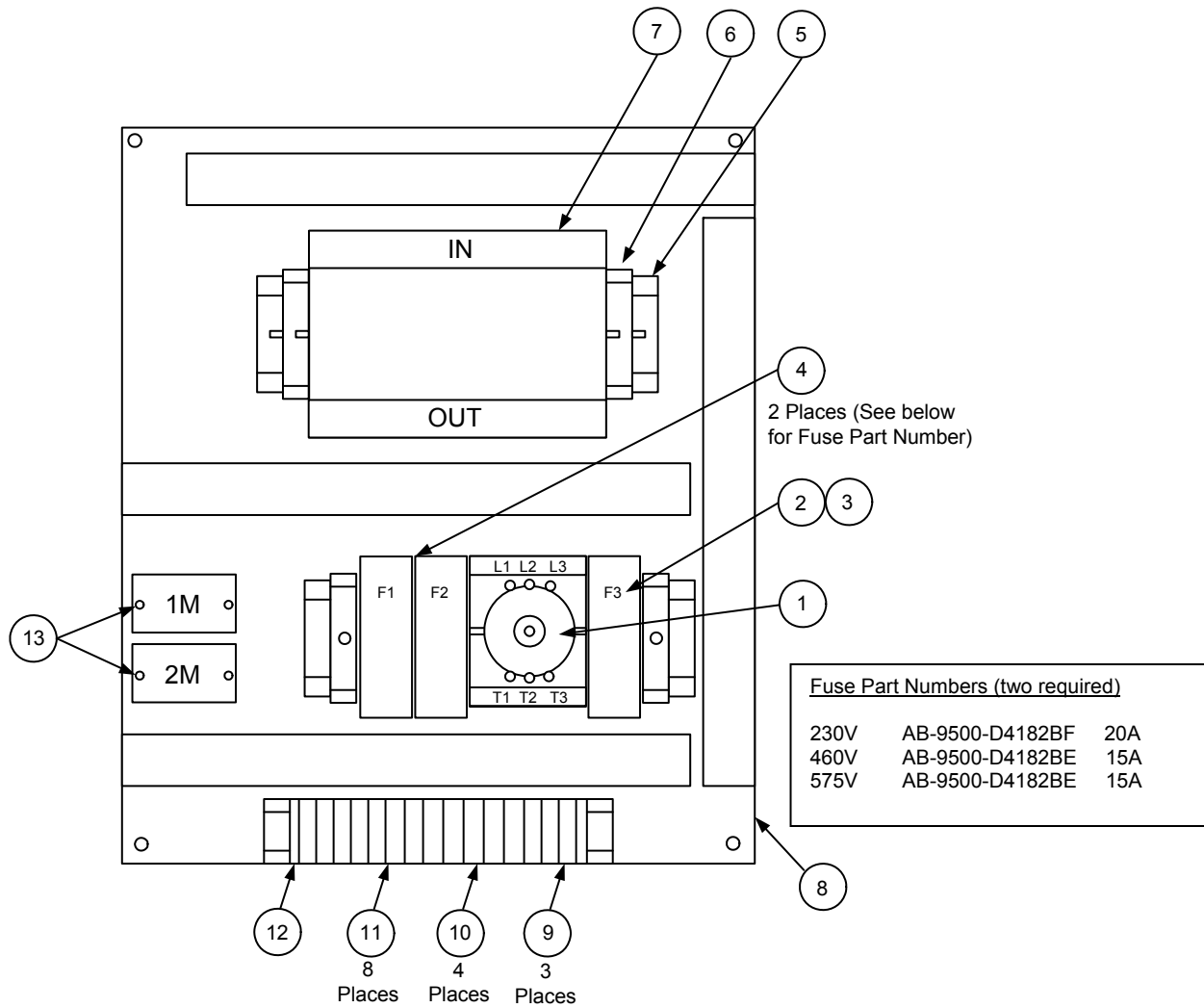

**Figure 6-10b. Electrical Panel Components Layout for Units with Relay Logic  
(230, 460 and 575 Volts)  
(For unit built after 01/01/2013)**

<b>Table 6.10.1b: Electrical Panel Components Layout for Units with Relay Logic Parts Listing</b>			
<b>Item Number</b>	<b>Part Number</b>	<b>Description</b>	<b>Quantity</b>
6-10b -1	AB-9500-D4115	Disconnect Switch	1
6-10b -2	AB-9500-D2896	Fuse Holder	1
6-10b -3	AB-9500-D4182AK	Fuse, 2A	1
6-10b -4	AB-9500-D2896B	Fuse Holder	2
6-10b -5	AA-9500-D4138E	End Stop	4
6-10b -6	AB-9500-D4134	Expansion Module	A/R
6-10b -7	PA-00440-D4133P12	PLC, Assembly	1
6-10b -8	PD-00440-1EAD230	Panel	1
6-10b -9	PB-00946-1EAD82	Terminal Block	A/R
6-10b -10	PB-00946-1EAD88	Connector	A/R
6-10b -11	PB-00946-1EAD86	Terminal Block	A/R
6-10b -12	PB-00946-1EAD89	End Plate	2
6-10b -13	AB-9500-D4114	Relay, Power	2



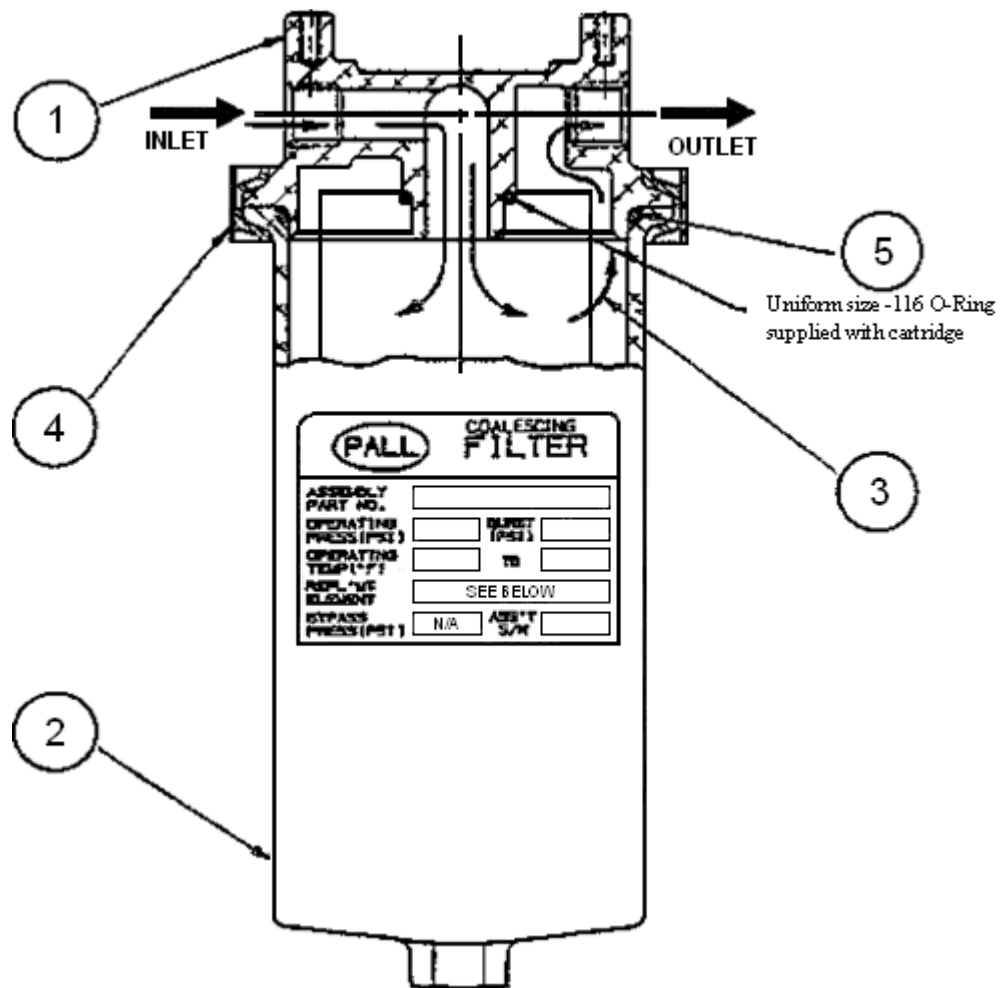

Figure 6-11: PD-00946-SU80 [G] B Coalescing Filter Assembly

**Table 6.11.1: B Coalescing Filter Assembly Parts Listing**

Item Number	Part Number	Description	Quantity
6-11-1	MDY-4463-6D12W MDA-4463-8D1 MDA-4463-8D1	Filter Head for Seal Code H Filter Head for Seal Code J Filter Head for Seal Code Z	1
6-11-2	MDY-4463-6D22W AA-9500-D2163 AA-9500-D2163	Filter Bowl for Seal Code H Filter Bowl for Seal Code J Filter Bowl for Seal Code Z	1
6-11-3	AA-4463F-1 AA-4463F-1J AA-4463F-1Z	Filter Element for Seal Code H Filter Element for Seal Code J Filter Element for Seal Code Z	1
6-11-4	AA-4463-6D3	V-Band Clamp	1
6-11-5	Uniform Size--146	O-Ring (see Table 6-11)	1

**Table 6.11.2: O-Ring Compatibility Table**

P/N O-Ring Compound	Seal Material	Fluid Serviced
MS28775-	Buna N	Petroleum
M832481-	Viton	Petroleum, Specified Synthetics
NAS1611-	EPR	Type IV Phosphate Esters (Skydrol 500)

Example: MS28775-327 indicates “uniform size -327” O-Ring with Buna N seals for petroleum base fluid being serviced.

**NOTE:** Switch actuates at  $50 \pm 7.5$  PSID.

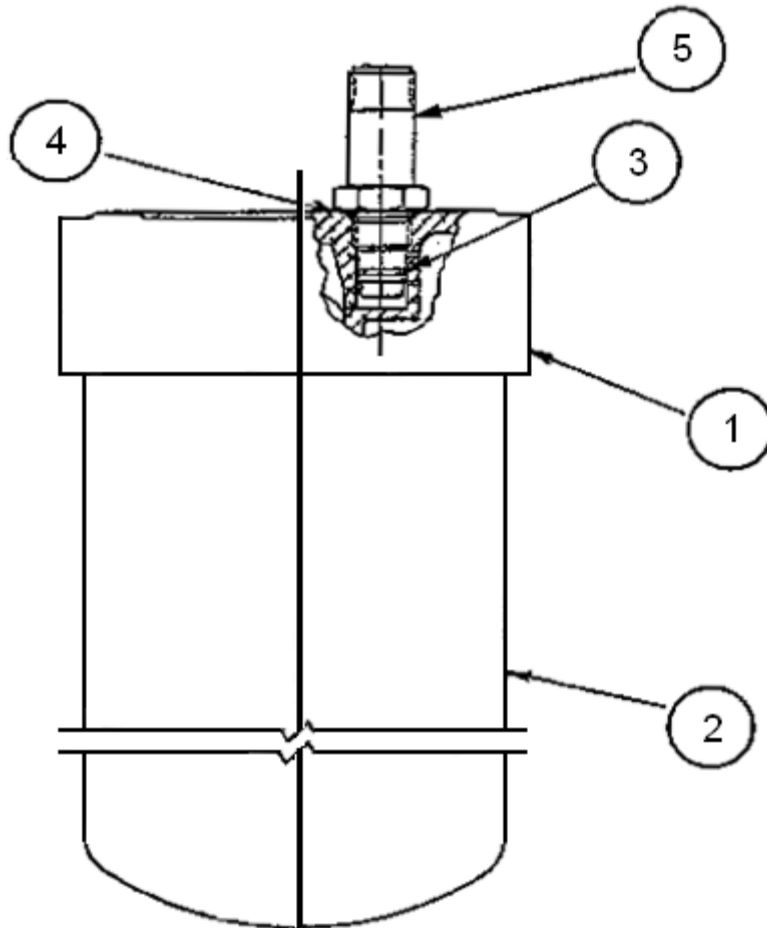

**Figure 6-12. GD-00273-168[G] Discharge Filter Assembly**

**Table 6.12.1: Discharge Filter Assembly Parts Listing**

Item Number	Part Number	Description	Quantity
6-12-1	PD00440F16ASSY PD00440F16ASSYJ PD00440F16ASSYZ	Head Assembly, Non-Bypass for Seal Code H Head Assembly, Non-Bypass for Seal Code J Head Assembly, Non-Bypass for Seal Code Z	1
6-12-2	GC-00273F-168H GC-00273F-168J GC-00273F-168Z	Filter Element for Seal Code H Filter Element for Seal Code J Filter Element for Seal Code Z	1
6-12-3	UNIFORM SIZE – 014	O-Ring (see Table 6-12)	1
6-12-4	MS28778-8 M83248-2-908 NAS1612-8	Boss Seal for Seal Code H Boss Seal for Seal Code Z Boss Seal for Seal Code J	1
6-12-5	RC991CZ09128775 RC991CJ0911611 RC991CZ09183248	Differential Pressure Switch for Seal Code H Differential Pressure Switch for Seal Code J Differential Pressure Switch for Seal Code Z	1

**Table 6.12.2: O-Ring Compatibility Table**

P/N O-Ring Compound	Seal Material	Fluid Serviced
MS28775-	Buna N	Petroleum
M832481-	Viton	Petroleum, Specified Synthetics
NAS1611-	EPR	Type IV Phosphate Esters (Skydrol 500)

Example: MS28775-014 indicates “uniform size -014” O-Ring with Buna N seals for petroleum base fluid being serviced.