



Life Sciences

User Guide

USD 2516 Rev A

Pall Advanta™ Electrical Trace Heaters

Table of Contents

1. Introduction.....	1
1.1 Description.....	1
1.2 Specifications.....	3
2. Temperature Controller Operating Instructions	4
2.1 Displays.....	5
2.2 Operation Keys.....	5
2.3 LED Lamps	5
3. Start-up.....	6
4. Temperature Controller Setting Instructions	7
5. Temperature Controller Alarm Settings	11
6. Error Messages and Troubleshooting	12
7. Spare Parts	13
8. Electrical Schematic of the Controller	14
9. WEEE Compliance	15
9.1 Re-use, Recycling, and Recovery (2002/96/EC).....	15

List of Figures

Figure 1: General Arrangement of Filter Housing Heating System.....	1
Figure 2: Temperature Control Unit.....	2
Figure 3: Volt Free Alarm Output Pin Socket	2
Figure 4: Temperature Controller Display.....	4
Figure 5: Process and Setting Values.....	6
Figure 6: Electronic Waste Materials Label.....	15
Figure 7: CE Compliance.....	15

List of Tables

Table 1: Temperature Control Unit Specifications.....	3
Table 2: Heating Jacket Specifications.....	3
Table 3: Set 1 Variable Settings.....	6
Table 4: Set 2 Variable Settings.....	7
Table 5: Set 3 Variable Settings.....	8
Table 6: Set 4 Variable Settings.....	8
Table 7: Set 5 Variable Settings.....	9
Table 8: Error Messages	10
Table 9: Ordering Information	11

Learn About Safety

Please read the following instructions carefully and completely before using the Pall Advanta Electrical Trace Heaters.

This manual is provided to serve as the installation, operation and maintenance guide for the equipment supplied in accordance with the details given in the customer's purchase order. The contents should be read before attempting any phase of installation or operation. A product label has been permanently attached to the equipment. When requesting information, service or spare parts, please refer to the **information on** this label.

Safety of Personnel

Avoid any working practice which:

- Endangers the health and safety of the user or third parties
- Is detrimental to the unit or others
- Impairs the safety and operation of the unit
- Does not comply with the safety instructions

Servicing and maintenance should only be completed by suitably qualified persons, who are familiar with the unit and who have been informed of all potential hazards.

Safety Conventions in this Manual

Safety information is identified in this instruction manual by the following convention:

Information



Identifies important information about the current topic.

Caution



Caution: Identifies a situation that may cause product damage and can cause personal injury.

Warning



Warning: Identifies a dangerous or potentially dangerous situation that may cause irreversible damage to equipment and poses a safety risk that can cause serious personal injury.

Personal Safety

1. Complete the following safety procedures:
 - (a) Read about the operating limits of the product and the proper methods for use detailed in this User Guide.
 - (b) Ensure that sanitization and process conditions do not exceed the operating limits of the capsule and its associated assembly.
 - (c) Check that the process equipment and the capsule meet local safety codes.
 - (d) Inspect the capsule and connections for any damaged components.
2. Always wear protective clothing, including safety glasses and gloves when working with capsules, equipment, samples, and reagents.
3. Provide sufficient space for assembling all system components and operating the system.
4. Some system components may be very heavy. Take proper precautions when moving or lifting equipment to prevent personal injury. In some cases, hoists or other lifting equipment may be required.



*Warning: Never dismantle or disable any safety device.
Check the safety devices regularly for correct operation.
Malfunctions and defects concerning the safety devices must be reported to the after sales service of Pall.*



Caution: There are no user serviceable parts available for the controller or heating jacket.

1. Introduction

1.1 Description

The Pall Advanta™ Electrical Trace Heater System is a kit consisting of a temperature control unit and a heating jacket (Figure 1). Heating jackets are available in a number of different materials and sizes, see [Table 9: Ordering Information on page 13](#) for additional information. The temperature controller (Figure 2) is used to regulate the temperature of the heater jacket.

Figure 1: General Arrangement of Filter Housing Heating System

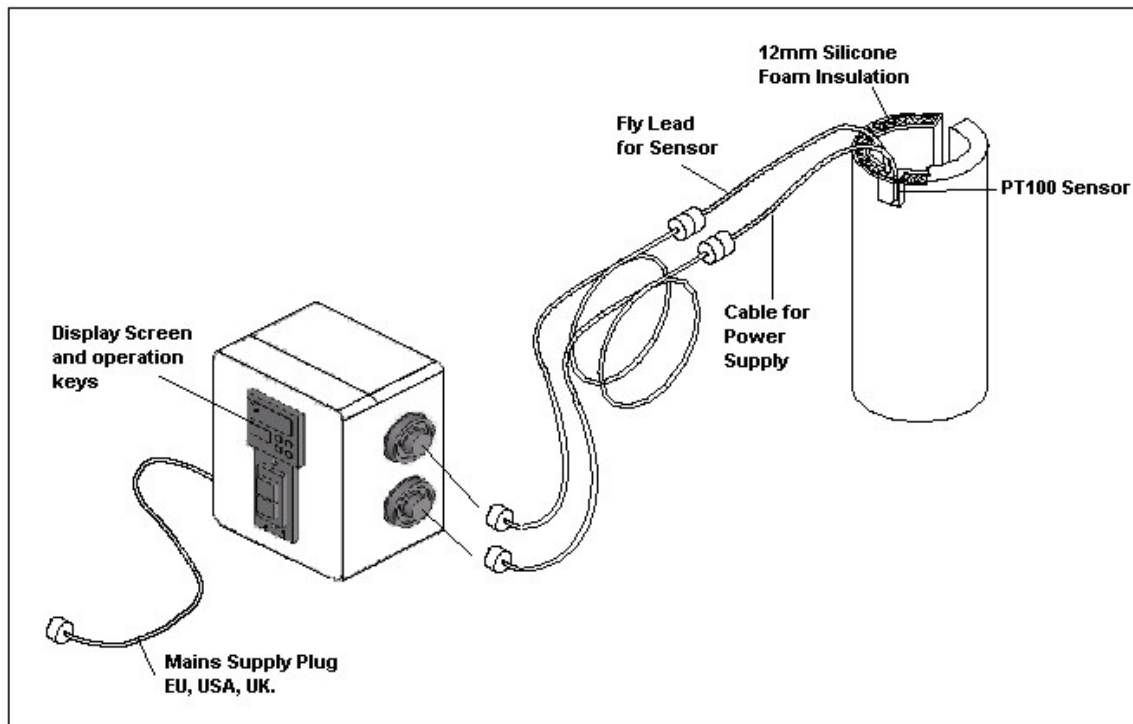
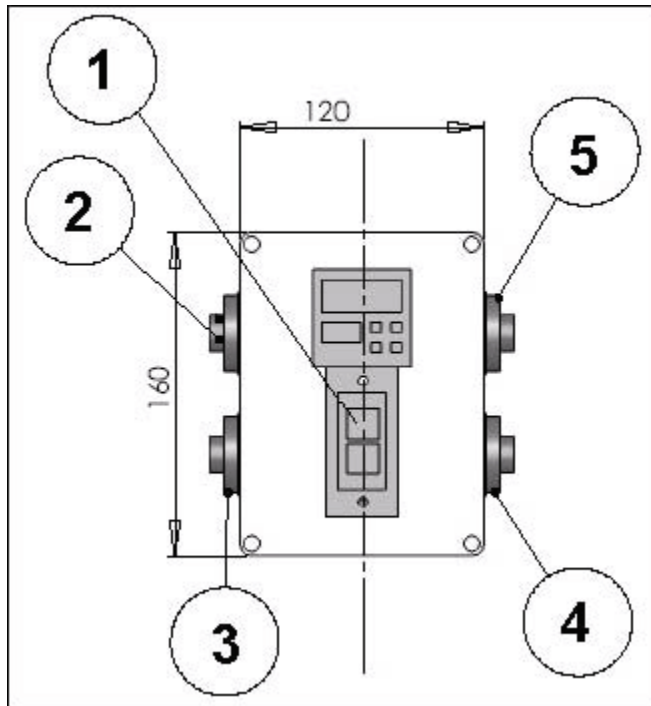


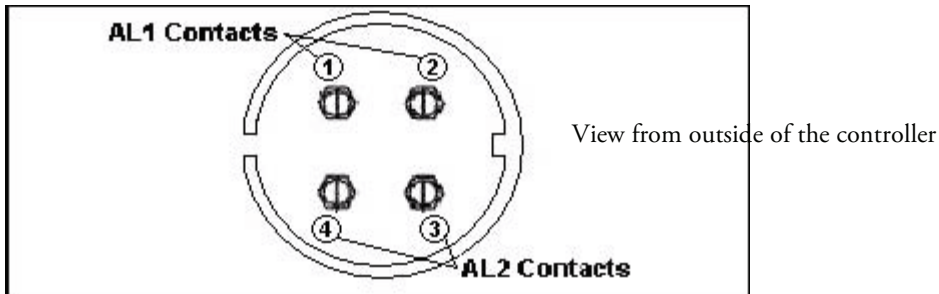
Figure 2: Temperature Control Unit



Key

1. ON/OFF Run Switch – green switch must be depressed for controller to operate. Also acts as a trip switch if too much current is supplied.
2. Volt Free Alarm Output pin socket (Figure 3). 1 and 2 are Alarm 1 contacts and 3 and 4 are Alarm 2 contacts. The cover on this connection can be used to tighten and unscrew the pin sockets on all of the connectors.
3. Mains Power Supply connection.
4. Power supply to heater jacket connection
5. PT100 sensor connection.

Figure 3: Volt Free Alarm Output Pin Socket



1.2 Specifications

Table 1: Temperature Control Unit Specifications

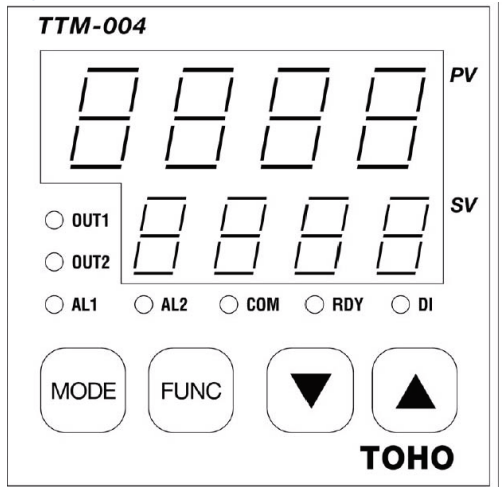
Power Supply Voltage	110 or 240V AC, 50/60Hz
Power Consumption	Dependent on heater jacket selection
Memory Element	EEPROM
Sensor Input	PT100, R.T.D. enclosed in heater jacket
Control Output	SSR relay contact
Alarm Output 1	Relay contact, 250 VAC 0.5A (resistive load)
Alarm Output 2	Relay Contact, 150 VAC 1.0A (resistive load)
Control Method	Two kinds of PID, ON/OFF
Operating Environment	0 – 50 °C (32 – 122 °C)
Storage Environment	-25 to 70 °C (-13 to 158 °F)
Display Front Dimensions	48 mm x 48 mm
Environmental Protection	IP65

Table 2: Heating Jacket Specifications

Jacket Material:	Silicone rubber
Insulation Material	Silicone foam
Operating Voltage	Refer to name plate
Power Output	120 mm = 90W 305 mm = 300W 559 mm = 600W
Maximum Withstand Temperature De-energized	200 °C (392 °F)
Alarm Output 1	PT100
Alarm Output 2	150 °C ± 5 °C (302 °F ± 41 °F)
Thermal Cut-out Temperature Setting	Two kinds of PID, ON/OFF
Testing Voltage:	1500V
Insulation Value:	Greater than 100 MΩ
Protection Rating:	IP65
Design Standards:	EN 60519-1 and EN 60519-2

2. Temperature Controller Operating Instructions


Figure 4: Temperature Controller Display



2.1 Displays

Display	Indication
PV (Display)	Process variable (actual process variable)
SV (Display)	Setting value (required process value)

2.2 Operation Keys

Key	Function
Mode	Changes each mode in settings menus (changes display mode)
FUNC	Can be used to carry out a specific action such as a digit shift or changing between RUN and Ready control, or the start and rest button for the timer
	Up and Down keys are used to change digits when setting the controller, and when moving between settings (e.g., Set1 to Set2)

2.3 LED Lamps

Lamp	Function
AL1	Alarm 1 represents Output 1. It is activated when the temperature falls below the absolute value low limit. This value is set to 80 °C (146 °F).
AL2	Alarm 2 represents Output 2. It is activated when the temperature rises above the absolute value high limit. This value is set to 120 °C (248 °F)
OUT1	Shows that current is being supplied to the heater, heater is on.
OUT2	Not Used
COM	Not Used
RDY	Ready light is activated when the Function is changed to RUN/READY; it means that the system is in the control stop position
DI	Not Used



Warning: The set points should not exceed the operational limits of the cartridge or housing. Please refer to the cartridge technical details for more information.

3. Start-up

1. Attach the heater jacket power supply and sensor cables to the controller and plug the power cord into the nearest compatible electricity supply.
2. Turn the power on at the mains and wait until the Process and Settings Values (Figure 5) appear.

Figure 5: Process and Setting Values



The default setting value is set at 100 °C (212 °F).

3. Use the up and down arrow keys to change the setting value — minimum = 0 °C (32 °F) and maximum = 150 °C (302 °F).
4. Push the green on switch to start the heater working.
5. The Control Unit must be switched off when equipment the heater jacket is fitted to is steam-sterilized.

4. Temperature Controller Setting Instructions

To check that all settings are set to their default values, or to change the various options of the controller to a custom setting, Tables 3 – 5 can be used.

1. First ensure the controller is not running by depressing the red switch, some options can be changed while the controller is running but most cannot.
2. Depress the mode key for 2 – 3 seconds to enter the setting mode (the Set 1 screen appears).
3. Use the arrow keys to scroll through the Set menus, and the mode key to scroll through options.

Table 3: Set 1 Variable Settings

Screen Display	Setting Function	Set Value	Setting Options
	Sensor Input Type	10	10 – PT100
	PV Correction Gain	1.00	
	Zero Point Setting for PV Correction	0	
	Filter Input	1	
	Decimal Point Position	0	0 = Decimal not required 0.0 = Decimal required
	Function Key Setting	0	0 = Nothing 1 = Change of digit 2 = Run/Ready 3 = Auto-Tuning 4 = Timer
	Key Locking	0	0 = None 1 = All Lock 2 = Operation Mode Lock Only 3 = Except Operation Mode

Table 4: Set 2 Variable Settings



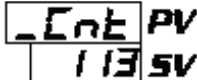
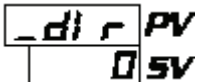
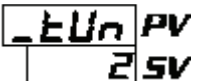

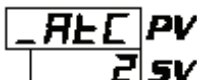
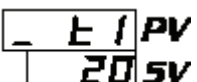


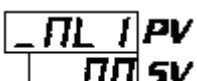
Screen Display	Setting Function	Set Value	Setting Options
	High Limit of Set Value Temperature	150 °C (302 °F)	
	Low Limit of Set Value Temperature	0 °C (32 °F)	
	Control Mode Setting	Run	Run = Control Performance Ready = Non-control Performance
	Control Type Selection	113	
	Jacket Use (Heating/Cooling)	0	0 = Heating
	Manipulated Value for Output 1	0.0	Display Range: 0.0-100.0%
	PID Tuning Type	2	1 = Auto Tuning Output 1 2 = Self Tuning Output 1
	Auto-Tuning Coefficient	1.0	
	Auto-Tuning Sensitivity	2	
	Proportional Cycle Time	20	
	Anti-reset Wind-up	100.0%	
	High Limit Manipulated Value for Output 1	100.0	
	Low Limit Manipulated Value for Output 1	0.0	
	Manual Reset	0.0	

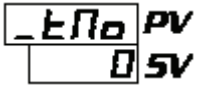

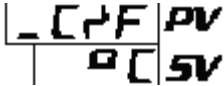
Table 5: Set 3 Variable Settings

Screen Display	Setting Function	Set Value	Setting Options
	Alarm 1 Function Setting for EV1	07	0 = None 7 = Absolute Value of Low Limit
	Low Limit Alarm 1 Value for EV1	80 °C (176 °F)	
	Sensitivity For EV1	0	
	Delay Timer for EV1	0	
	Action to Outbreaks of Anomalies EV1	00	
	Polarity Setting EV1	0	

Table 6: Set 4 Variable Settings

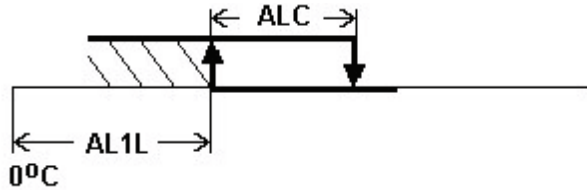
Screen Display	Setting Function	Set Value	Setting Options
	Alarm 2 Function Setting for EV2	06	0 = None 6 = Absolute Value of High Limit
	Low Limit Alarm 1 Value for EV2	120 °C (248 °F)	
	Sensitivity For EV2	0	
	Delay Timer for EV2	0	
	Action to Outbreaks of Anomalies EV2	00	
	Polarity Setting EV2	0	

Table 7: Set 5 Variable Settings

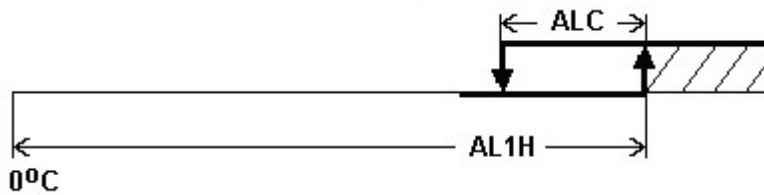
Screen Display	Setting Function	Set Value	Setting Options
	Timer Output	0	
Extra Settings			
	Priority Displays		
	Temperature Unit Change (°C – °F)	°C	

5. Temperature Controller Alarm Settings

The AL1 LED will illuminate when the temperature picked up by the sensor falls below the absolute low limit value for event output 1. An Alarm operation can also be set to act when this alarm condition is reached. This value is defaulted to 80 °C (176 °F). This value can be changed in Set 3 ([Table 5: Set 3 Variable Settings on page 9](#)).



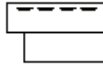
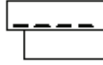
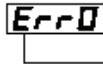



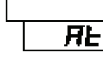
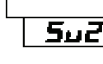


The AL2 LED will illuminate when the Temperature picked up by the sensor rises above the absolute high limit value for event output 2. An Alarm operation can also be set to act when this alarm condition is reached. This value is defaulted to 120 °C (248 °F). This value can be changed in Set 4 ([Table 6: Set 4 Variable Settings on page 9](#)).



ALC = Alarm Condition

6. Error Messages and Troubleshooting

Table 8: Error Messages

Screen Display	Error	Troubleshooting
	Input value exceeds the higher limit of the display range. It will also show when there is no sensor input to the controller.	Check that the sensor cable is attached correctly and that no wires have been broken.
	The input value exceeds the lower limit of the display range.	Check for short circuit of input lines.
	Memory error.	Turn off power supply, and then turn back on. If error message persists, return to supplier for repair.
	A/D converter error, or a sensor connection is incorrect.	Turn off power supply, and then turn back on. If error message persists, return to supplier for repair.
	Auto-tuning error.	Check the sensor connection or change to another tuning setting.
	This displays when trying to change a parameter when the keys are locked.	Discontinue trying to change parameter, and unlock if necessary.
	Alternates between this display and the normal SV/PV display while auto-tuning.	This occurs in normal operation.
	This displays when setting value is changed on SV2 control.	Discontinue trying to change setting value.
	This displays when trying to change the setting value on the control display while the function key is on RUN/READY	Discontinue trying to change setting value.
	This displays when altering the setting value on the control display whilst in timer mode.	

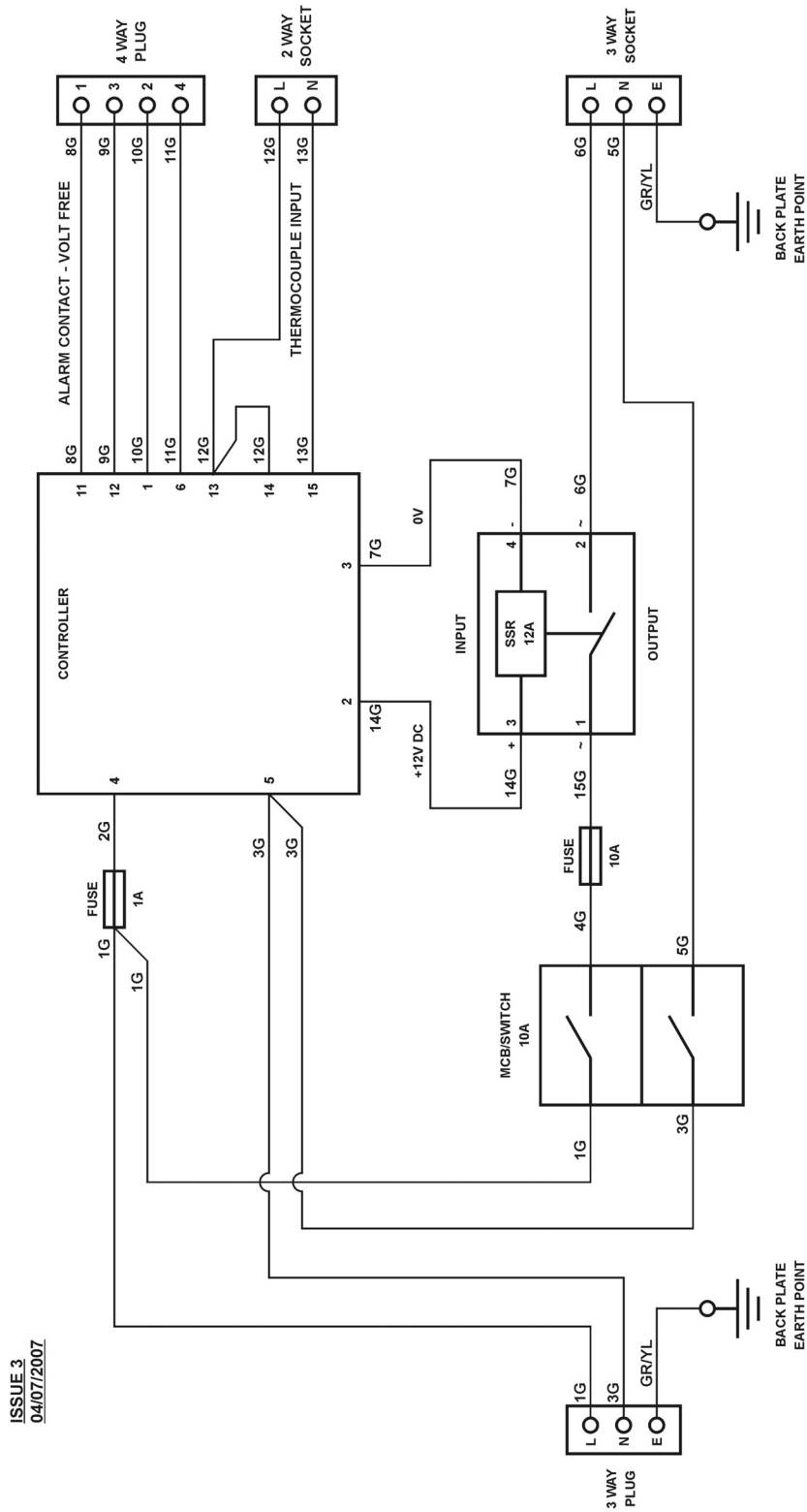
7. Spare Parts

When ordering spare parts, refer to Pall part numbers ACS0796AA 110Vac AB05 160W silicone heating jacket

Table 9: Ordering Information

ACS0828AA	110V ac AB05 160W silicone heating jacket Canadian
ACS0656AA	110V ac AB1 300W silicone heating jacket
ACS0790AA	110V ac AB1 300W silicone heating jacket Canadian
ACS0667AA	110V ac AB2 600W silicone heating jacket
ACS0829AA	110V ac AB2 600W silicone heating jacket Canadian
ACS0805AA	110V ac AB3 800W silicone heating jacket
ACS0832AA	110V ac AB3 800W silicone heating jacket Canadian
ACS0859AA	Temperature Control Unit 110/240V Centigrade Display
ACS0860AA	Temperature Controller 110/240V Fahrenheit Display
ACS0735AA	110V ac SLK702 90W silicone heating jacket
ACS0830AA	110V ac SLK702 90W silicone heating jacket Canadian
ACS0797AA	240V ac AB05 160W silicone heating jacket
ACS0627AA	240V ac AB1 300W silicone heating jacket
ACS0666AA	240V ac AB2 600W silicone heating jacket
ACS0806AA	240V ac AB3 800W silicone heating jacket
ACS0736AA	240V ac SLK702 90W silicone heating jacket
ACS0865AA	Temperature and Power Connector Cable 10 m
ACS0864AA	Temperature and Power Connector Cable 2 m
ACS0862AA	Power Cable 2 m European Schuko
ACS0861AA	Power Cable 2 m UK BS1363/A
ACS0863AA	Power cable 2 m US 3 Pin IEC/3
ACS0792AA	Cable Supply 2 m long Canadian
ACS0824AA	Cable Supply 10 m long Canadian
ACS0877GA	In-Line Flex Mounting Connector — 3-pole, screw termination, socket contacts
ACS0878GA	Flex Mounting Connector Bulgin — 3-pole, screw termination, pin contacts
ACS0879GA	In-Line Flex Mounting Connector — 2-pole, screw termination, socket contacts
ACS0880GA	Flex Mounting Connector — 2-pole screw termination, pin contacts
ACS0881GA	Flex Mounting Connector Bulgin — 3-pole, screw termination, socket contacts
ACS0882GA	Flex Mounting Connector — 4-pole, screw termination, socket contacts
LP00757	User Guide USD 2516 Rev A and Packing

8. Electrical Schematic of the Controller



earth = ground

The Control Box is grounded/earthed through the mains power cable.

9. WEEE Compliance

9.1 Re-use, Recycling, and Recovery (2002/96/EC).

The presence of a electronic waste materials label (Figure 6) on a product means that the product contains electrical or electronic materials and therefore should not be disposed of as unsorted waste but instead treated separately. The presence of these materials may, if not disposed of properly, have potential adverse effects on the environment and human health. Within the European Union users are urged to recycle such products when being replaced with a newer version or when they have outlived their useful lives. However as the legislation and facilities vary throughout the member states, please contact your local Pall sales office or distributor to discuss the available options for correctly disposing of this product.

Figure 6: Electronic Waste Materials Label



Figure 7: CE Compliance





Life Sciences


New York — USA
+1 800 717 7255 toll free
+1 516 484 5400 phone
+1 516 801 9548 fax
biotech@pall.com e-mail

Portsmouth — Europe
+44 (0)23 9230 3303 phone
+44 (0)23 9230 2506 fax
BioPharmUK@europe.pall.com e-mail

Visit us on the web at www.pall.com/biopharmaceutical

Pall Corporation has offices throughout the world in locations including: Argentina, Australia, Austria, Belgium, Brazil, Canada, China, France, Germany, India, Indonesia, Ireland, Italy, Japan, Korea, Malaysia, Mexico, the Netherlands, New Zealand, Norway, Poland, Puerto Rico, Russia, Singapore, South Africa, Spain, Sweden, Switzerland, Taiwan, Thailand, United Kingdom, the United States, and Venezuela.
Distributors are located throughout the world.

All data, specifications and information contained in this publication are based on information we believe reliable and represent values in effect at the time of printing. Pall Corporation reserves the right to make changes without prior notice.

 PALL, Pall, and Pall Advanta are trademarks of Pall Corporation.

Filtration.Separation.Solution. is a service mark of Pall Corporation.

Part Numbers quoted above are protected by the Copyright of Pall Corporation.

® indicates a trademark registered in the USA.

© 2008, Pall Corporation

USD 2516 Rev A LP00757 3/2008

Filtration. Separation. Solution.SM