



Biotech

USD 2233g

## Instructions For Use

### Pall Kleenpak® Sterile Connector



These instructions should be read thoroughly as they contain valuable information gained by extensive experience. This product is not sold sterile. For use in making sterile connections, each connector must be fitted in a closed, single-use assembly that has been subjected to a validated sterilized process. It is very important that all instructions are carefully followed and where appropriate should be incorporated into the user's standard operating procedures. If some of the procedures do not suit your needs, please consult Pall or your local distributor before finalizing your system.

## 1. Specifications

The Kleenpak sterile connector has a maximum working pressure of 3 bar (43.5 psi) at 40 °C in compatible fluids.



*Warning: Operation outside the above specifications and/or with fluids incompatible with construction materials may cause personal injury and result in damage to the device.*

## 2. Receipt of Equipment

The male and female Kleenpak sterile connectors are supplied in separate packages. There are several types of end fittings in order to match different tubing size requirements and to allow for different attachment possibilities to flexible tubing. To access full part number availability, consult our website at [www.pall.com/biotech](http://www.pall.com/biotech).

- (a) Store the male and female Kleenpak sterile connectors in clean, dry conditions and wherever practical in the external packaging as delivered.
- (b) DO NOT remove from the inner device bag packaging until just before installation.
- (c) Male and female Kleenpak sterile connectors are supplied protected by an inner and outer bag. Ensure that the packaging is undamaged.
- (d) The assembly aid is provided non sterile and can be reused multiple times. It needs to be stored in clean and dry conditions between each use. The assembly aid is supplied separately and is available for purchase from your local Pall representative.

## 3. Installation

Before installation, it is essential to verify that the Kleenpak sterile connector is suitable for the liquid that it will be in contact with for the application and to follow the appropriate instructions listed below.

- (a) Install the male and female Kleenpak sterile connectors using compatible connections. Ensure that the tubing is attached firmly to the hose barb to prevent leakage during operation using cable ties or other methods. During tubing assembly, premature actuation of the male plunger is prevented by the anti-actuation ring. The anti-actuation ring needs to remain in place until actual connection takes place. The presence of valves on the tubing before the connector is recommended to prevent liquid contact with the Kleenpak sterile connectors prior to use.
- (b) If the connectors are to be autoclaved, orientate them with peel strips orientated upwards to prevent peel strip blockage by condensate.



*Warning: The device must remain dry prior to connection of the male and female Kleenpak sterile connectors. If there is fluid present in the line or around the devices, do not use. If the protective cap has been removed, do not use.*

## 4. Sterilization



*Warning: These disposable Kleenpak sterile connectors must not be in-line steam sterilized. Material design limitations will be exceeded when these devices are exposed to pressurized steam and they will be ruptured.*

### 4.1 Gamma Irradiation

- (a) Connect the male or female Kleenpak sterile connector to the single use system to be sterilized. A valve or clamp needs to be installed close to the connector to prevent accidental wetting after the system is filled with liquid.
- (b) Ensure that the protective cap is firmly in place. Autoclave paper or other radiation resistant material can be used to ensure that the cap does not become dislodged during handling.
- (c) It is recommended that the entire assembly be placed in an inner and outer bag for protection prior to gamma irradiation.
- (d) Sterilize by gamma radiation. The maximum allowable radiation dose is 50 kGy (5 Mrad).



*Important: Pall recommends that the efficiency of the sterilization cycle is validated using an appropriate method.*

- (e) These connectors have not been validated for repeated gamma sterilization exposure.

### 4.2 Autoclave Sterilization

- (a) Install the male or female Kleenpak sterile connector to the equipment to be sterilized. If the Kleenpak sterile connector is attached to a tank, the tank should be vented appropriately with a vent filter.
- (b) Ensure that the protective cap of the Kleenpak sterile connector is firmly in place. Autoclave paper or other autoclavable and air/steam permeable material can be used to cover the cap loosely to ensure that the cap does not become dislodged during handling.
- (c) The Kleenpak sterile connectors should be allowed to vent during autoclaving. The venting strip should be orientated upwards to prevent blockage by condensates. *Warning: To avoid collection of condensate within the connectors do not place the venting strip downwards during autoclaving.*
- (d) The connectors should not be covered with heavy objects during the autoclave cycle.



*Note: The maximum temperature is 130 °C for KPCHT part numbers and the maximum exposure time is 75 minutes.*

*Do not autoclave at a higher temperature or for a longer time. A slow exhaust cycle is recommended.*



*Warning: Do not autoclave the male and female connectors in the bags that they are shipped in.*



*Important: Pall recommends that the efficiency of the sterilization cycle is validated using an appropriate method.*

## 5. Making the Connection



*Warning: Do not use if fluid is in contact with the connector. Do not use if protective caps are loose or displaced.*

If using the assembly aid to connect the female and male Kleenpak sterile connectors together, follow Section 5.1. Otherwise, proceed to Section 5.2.

**Figure 1**  
*Kleenpak Sterile Connector Schematic*

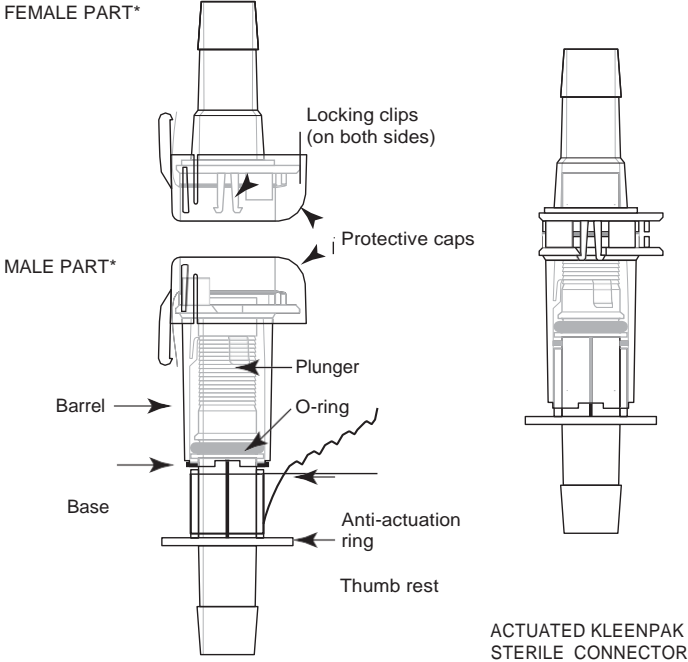

**5.1 Making the Connection using the Kleenpak Sterile Connector Assembly Aid**

- (a) Lift and pull tab off protective caps to remove caps from the Kleenpak sterile connectors (Figure 2).

**Figure 2**  
 Step (a)

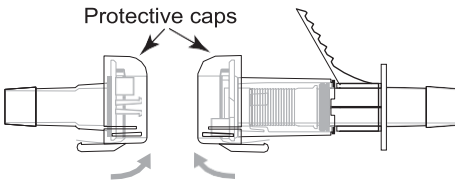

- (b) Hold the barrel of the larger (male) Kleenpak sterile connector above the base.
- Align the smaller (female) Kleenpak sterile connector with the larger (male) Kleenpak sterile connector
  - Flat sides should be aligned
  - Both peel away strips need to remain folded (Figure 3).

 **Warning:** Do not alter the peel away strip fold position during installation as this prevents a proper connection from being made.

**Figure 3**

Step (b)

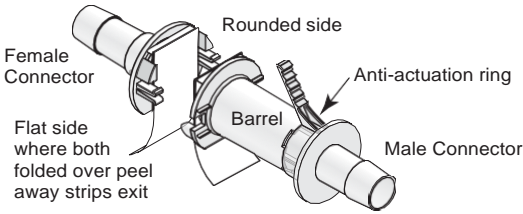

*Warning: If the Kleenpak sterile connectors are not aligned properly, the connection cannot be made.*

- (c) Once aligned correctly, press the two connectors together firmly until both locking clips snap together tightly (Figure 4).

**Figure 4**

Step (c)

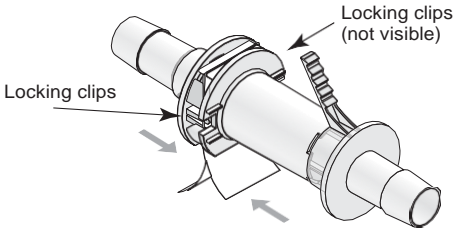

- (d) Support both the male and female Kleenpak sterile connectors, and remove the anti-actuation ring from the male connector by pulling the tab towards the barbed end of the male Kleenpak sterile connector (Figure 5).

**Figure 5**

Step (d)

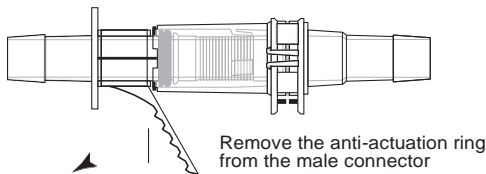

- (e) Place connected Kleenpak sterile connector firmly into assembly aid so that both peel away strips protrude through the opening and are easily accessible for removal (Figure 6).

**Figure 6**  
Step (e)

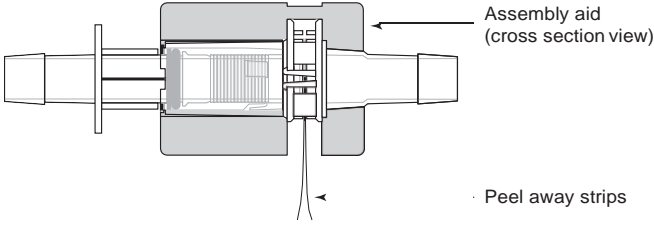

**Warning:** Kleenpak sterile connector should stay securely in the assembly aid when properly installed

- (f) Hold assembly aid in the palm of the hand with the Kleenpak sterile connector facing outwards, and thumb supporting the Kleenpak sterile connector in the assembly aid. Using the other hand, firmly grasp both peel away strips as close as possible to the body of the assembly aid to ensure a secure grip and keeping both peel strips straight, pull them away simultaneously in a smooth continuous motion. Ensure that the Kleenpak sterile connector is perpendicular to the peel away strips (Figures 7 and 8).

**Figure 7**  
Step (f)

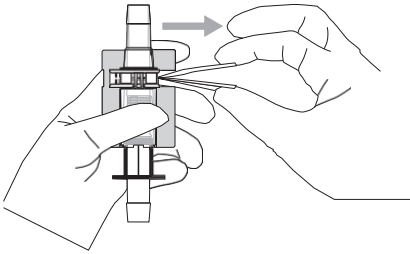

**Figure 8**  
Step (f) continued

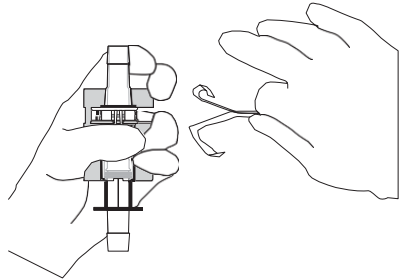

**Warning:** Do not use if only one peel away strip is removed accidentally instead of two, this will affect the sterility of the pathway.

**Warning:** Keep the peel strips straight to prevent the grommet from becoming unseated when removing the peel strip.

- (g) With Kleenpak sterile connector still secured in the assembly aid, push the thumb rest of the male Kleenpak sterile connector down towards the base of the barrel (Figures 9 and 10).

**Figure 9**  
Step (g)

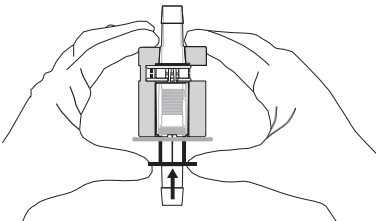

**Figure 10**  
Step (g) continued

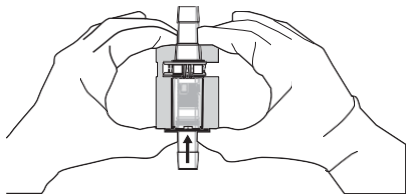



*Note that in order to establish a proper connection, the plunger inside the male Kleenpak sterile connector must be fully inserted into the female Kleenpak sterile connector. As a verification, repeat actuation until a hard stop is reached.*

If necessary, the Kleenpak sterile connector may be removed from the assembly aid to complete the plunger movement.

- (h) Once the Kleenpak sterile connector assembly is complete, the assembly aid may be removed. When assembly aid is removed, verify actuation until a hard stop is reached.
- (i) Start the fluid transfer (Figure 11).

**Figure 11**

Step (i)

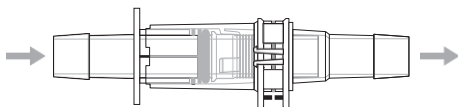

## 5.2 Making the Connection without using the Kleenpak Sterile Connector Assembly Aid

- (a) Lift and pull tab off protective caps to remove caps from Kleenpak sterile connectors (Figure 12).

**Figure 12**

Step (a)

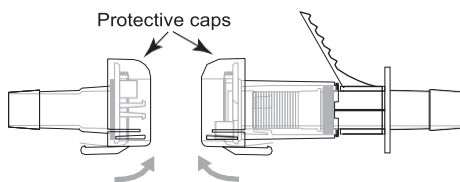

- (b) Hold the barrel of the larger (male) Kleenpak sterile connector above the base.

- Align the smaller (female) Kleenpak sterile connector with the larger (male) Kleenpak sterile connector
- Flat sides should be aligned
- Both peel away strips need to remain folded (Figure 13).



*Note: If the Kleenpak sterile connectors are not aligned properly, the connection cannot be made.*

**Figure 13**

Step (b)

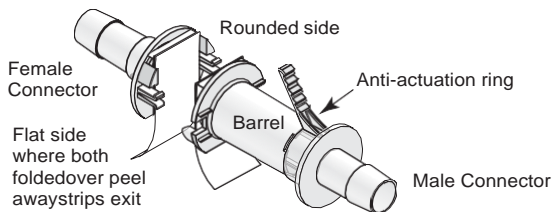

- (c) Once aligned correctly, press the two Kleenpak sterile connectors together firmly until both locking clips snap together tightly (Figure 14).

**Figure 14**

Step (c)

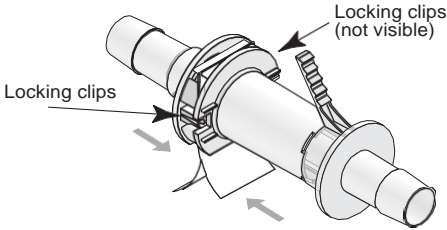

- (d) Support both the male and female Kleenpak sterile connectors, and remove the anti-actuation ring from the male connector by pulling the tab towards the barbed end of the male Kleenpak sterile connector (Figure 15).

**Figure 15**

Step (d)

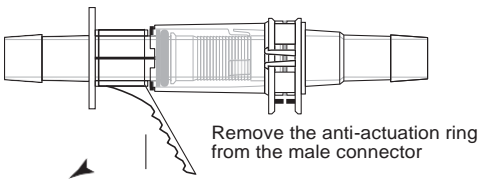

- (e) With one hand, support the male and female sides of the Kleenpak sterile connector by wrapping fingers around both sides of the connector, next to the flange. Using the other hand, grasp both white peel away strips as close as possible to the flat side of connector to ensure a good grip and pull them out simultaneously in a smooth continuous motion. Ensure that the connector is perpendicular to the peel away strips shown in shown in illustration for Step (e). The perpendicular orientation must be maintained while the two strips are pulled simultaneously. Do not use if only one white peel away strip is removed accidentally instead of two; this will affect the sterility of the pathway (Figures 16 and 17).



*Note: Do not impart perpendicular forces on the connector, as it can cause the connector to break. If a perpendicular force is present due to items attached to the Kleenpak sterile connector, then the Kleenpak sterile connector must be properly supported.*



**Figure 16**  
Step (e)

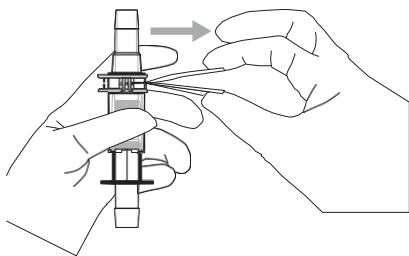

**Figure 17**  
Step (e) continued

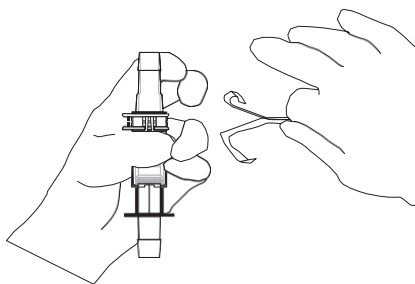

*Warning: Do not use if only one peel away strip is removed accidentally instead of two, this will affect the sterility of the pathway.*

*Warning: Keep the peel strips straight to prevent the grommet from becoming unseated when removing the peel strip.*

- (f) Push the thumb rest of the male Kleenpak sterile connector down towards the base of the barrel until they meet (Figures 18 and 19).

**Figure 18**  
Step (f)

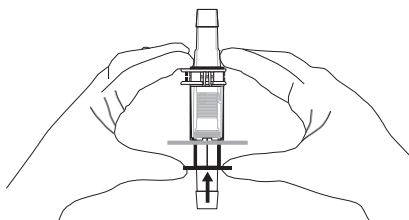

**Figure 19**  
Step (f) continued

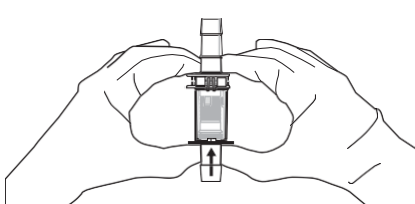

*Note that in order to establish a proper connection, the plunger inside the male Kleenpak sterile connector must be fully inserted into the female Kleenpak sterile connector. As a verification, repeat actuation until a hard stop is reached.*

- (g) Start the fluid transfer (Figure 20).

**Figure 20**  
Step (g)

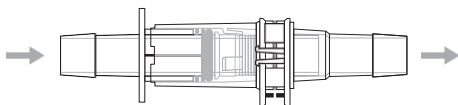

The Kleenpak sterile connector is designed for single use only. Discard the Kleenpak sterile connector in accordance with local Health and Safety Procedures. No attempt should be made to clean disposable assemblies.

## 6. Scientific and Laboratory Services

Pall operates a technical service to assist in the execution of our technologies and single use systems for all of your fluid management requirements. This service is readily available to you and we welcome your questions so that we can help. In addition, a full network of technical representatives is available throughout the world.

## 7. Warranty

Pall warrants that Kleenpak sterile connectors manufactured by Pall, when properly stored and installed, and operated within recommended ratings and specifications, following the current instructions of use supplied by Pall, will be free from defects in material and workmanship during their shelf life, which is five years from the date of manufacture (non-irradiated). For details of the shelf-life of Kleenpak sterile connectors post-gamma irradiation, please consult Pall. Pall liability under any warranty is limited solely to replacing, or issuing credit for, any Kleenpak sterile connector which may become defective during the Warranty Period.



**Corporate Headquarters**  
Port Washington, NY, USA  
+1.800.717.7255 toll free  
(USA)  
+1.516.484.5400 phone

**European Headquarters**  
Fribourg, Switzerland  
+41 (0)26 350 53 00 phone

**Asia-Pacific Headquarters**  
Singapore  
+65 6389 6500 phone

*Filtration. Separation. Solution.<sup>SM</sup>*

---

**Visit us on the Web at [www.com/biotech](http://www.com/biotech)**

**E-mail us at [biotech@pall.com](mailto:biotech@pall.com)**

---

**International Offices**

Pall Corporation has offices and plants throughout the world in locations such as: Argentina, Australia, Austria, Belgium, Brazil, Canada, China, France, Germany, India, Indonesia, Ireland, Italy, Japan, Korea, Malaysia, Mexico, the Netherlands, New Zealand, Norway, Poland, Puerto Rico, Russia, Singapore, South Africa, Spain, Sweden, Switzerland, Taiwan, Thailand, the United Kingdom, the United States, and Venezuela. Distributors in all major industrial areas of the world. To locate the Pall office or distributor nearest you, visit [www.pall.com/contact](http://www.pall.com/contact).

The information provided in this literature was reviewed for accuracy at the time of publication. Product data may be subject to change without notice. For current information consult your local Pall distributor or contact Pall directly.

© 2018, Pall Corporation. Pall  and Kleenpak are trademarks of Pall Corporation.  
® indicates a trademark registered in the USA. **Filtration.Separation.Solution.<sup>SM</sup>** is a service mark of Pall Corporation.

GN 20.07553

USD 2233g