

MEGA+ 500 Series Filter Housings

Five-Around, Electropolished Multi-Cartridge Housings

- Electropolished 316L Stainless Steel Materials of Construction for Maximum Corrosion Resistance
- 150 psig (10.3 bar) Maximum Operating Pressure Permits Use in a Wide Range of Applications
- Accepts Pall M3 (Code 3), M8 (Code 8) or DOE Style Filter Cartridges
- Accepts Five 10" (25.4 cm), 20" (50.8 cm), 30" (76.2 cm), or 40" (102 cm) Cartridges for an Optimum Choice at a Given Flow Rate
- Heavy Duty V-Clamp Closure Allows Quick, Easy Cartridge Change Out

Housing Specifications

Maximum Operating Pressure¹ (liquid service):

150 psig (10.3 bar) @ 200°F (93°C)

NOTE: Maximum operating pressure ratings are vessel ratings only. Safe operating temperature and pressure will depend on filter cartridge and gasket/O-ring used. For cyclical service please consult your Pall representative.

Construction:

Head:	316L Stainless Steel
Shell:	316L Stainless Steel
Vent Plug:	316 Stainless Steel
Drain Cap:	316 Stainless Steel
Bottom Seat Plate:	316L Stainless Steel

Connections:

Inlet/Outlet:	1 ½", 2" NPT
Vent:	¾" NPT
Drain:	¼" NPT

Shell O-rings:

Ethylene Propylene (standard),
Nitrile, Fluorocarbon Elastomer,
Silicone Elastomer

Connection Option:

Available with 150 lb. ANSI raised face flanges.



¹ - Not for use with compressed gases.

Dimensional Data (nominal)

Model	Liquid ² Flow Rates - gpm (lpm)	Dimensions - inches (cm)					Maximum Cartridge Diameter - inches (cm)	Weight - pounds (kg)	Overhead Clearance Required For Cartridge Removal - inches (cm)
		A	B	C	D	E			
5MEGA+1-1.5	to 25 (94.6)	25 (63.5)	6 3/4 (17.1)	2 7/8 (7.3)	12 (30.5)	12 7/8 (32.7)	2 3/4 (7)	37 (17)	31 (78.7)
10MEGA+2-1.5	to 50 (189.3)	33 1/2 (85.1)	6 3/4 (17.1)	2 7/8 (7.3)	12 (30.5)	12 7/8 (32.7)	2 3/4 (7)	42 (19)	48 1/2 (123.2)
15MEGA+3-2	to 75 (284)	44 (112)	6 3/4 (17.1)	2 7/8 (7.3)	12 (30.5)	12 7/8 (32.7)	2 3/4 (7)	48 (22)	72 (183)
20MEGA+4-2	to 100 (379)	54 1/2 (138.4)	6 3/4 (17.1)	2 7/8 (7.3)	12 (30.5)	12 7/8 (32.7)	2 3/4 (7)	54 (25)	89 1/2 (227.3)

² - Flow rates are listed for depth cartridges. Consult factory for more specific information.

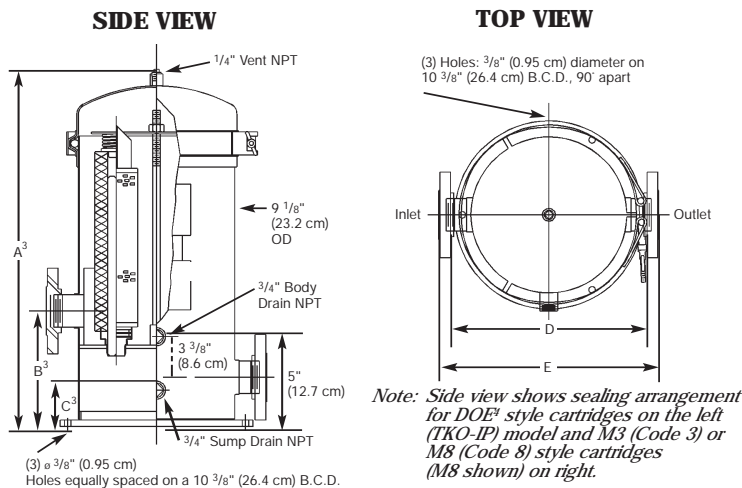

Housing Differential Pressure vs. Liquid Flow Rate

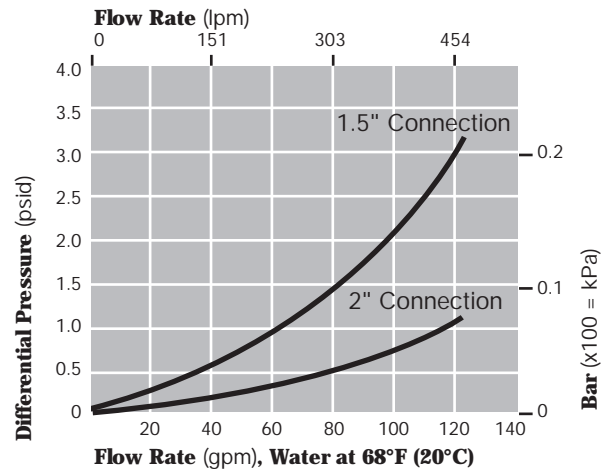

For liquids other than water, multiply differential pressure by fluid viscosity (cP).

Part Numbers/Ordering Information

MEGA+ ● - ◆ ▼ (e.g., 10MEGA+4-2F)

Code	No. of 10" Equivalents
5	5
10	10
15	15
20	20

Code	No. of 10" Equivalents Per Column
1	1
2	2
3	3
4	4

Code	Inlet/Outlet Connection Sizes
1.5	1.5" (standard) on 5 & 10 MEGA+
2	2" (standard) on 15 & 20 MEGA+

Code	Connection Styles
Blank	NPT
F	Flange

³ - Add 3/4" to dimensions for flanged version.

⁴ - When using double open end style filter cartridges, tube guides and springs are required. Contact your Pall Distributor for part numbers.



25 Harbor Park Drive
Port Washington, New York 11050

+1 888 873 7255 (toll free in U.S. only)
+1 516 484 3600 phone
+1 516 484 0364 fax

Visit us on the Web at www.pall.com

Pall Corporation has offices and plants throughout the world in locations including: Argentina, Australia, Austria, Belgium, Brazil, Canada, China, France, Germany, India, Indonesia, Ireland, Italy, Japan, Korea, Malaysia, Mexico, the Netherlands, New Zealand, Norway, Poland, Puerto Rico, Russia, Singapore, South Africa, Spain, Sweden, Switzerland, Taiwan, Thailand, United Kingdom, United States, and Venezuela. Distributors are located in all major industrial areas of the world.