

Marksman™ XLD High Flow Series Filter Elements

High Flow, High Capacity Pleated Polypropylene Filter Elements

- Large cartridge geometry
- Innovative joining of depth and pleated technologies
- High flow capacity¹
- Poly-Fine® Extended Life Depth (XLD) proprietary media for highly consistent filtration
- Inside to out flow traps contaminant inside the element
- Fits into standard Pall High Flow filter housings

Performance Specifications

Filter Grades:

1.5, 3, 4.5, 10, 20, 30, 70 micron (µm)

Maximum Operating Differential Pressure:²

50 psid (3.4 bard) @ 68°F (20°C)

35 psid (2.4 bard) @ 160°F (71°C)

Product Specifications

Materials of Construction:

Filter Medium: Polypropylene
 Support: Polypropylene
 End caps: 10% glass fiber reinforced polypropylene

Center core (60" length only): Polypropylene

O-ring/U-cup seal options: Ethylene propylene, Fluorocarbon elastomer, Nitrile

Dimensions (nominal):

Cartridge length: 20" (508 mm),
 40" (1016 mm),
 60" (1524 mm)

Cartridge max. OD: 6.3" (160 mm)

Medium OD: 5.9" (150 mm)

Medium ID: 3.5" (89 mm)

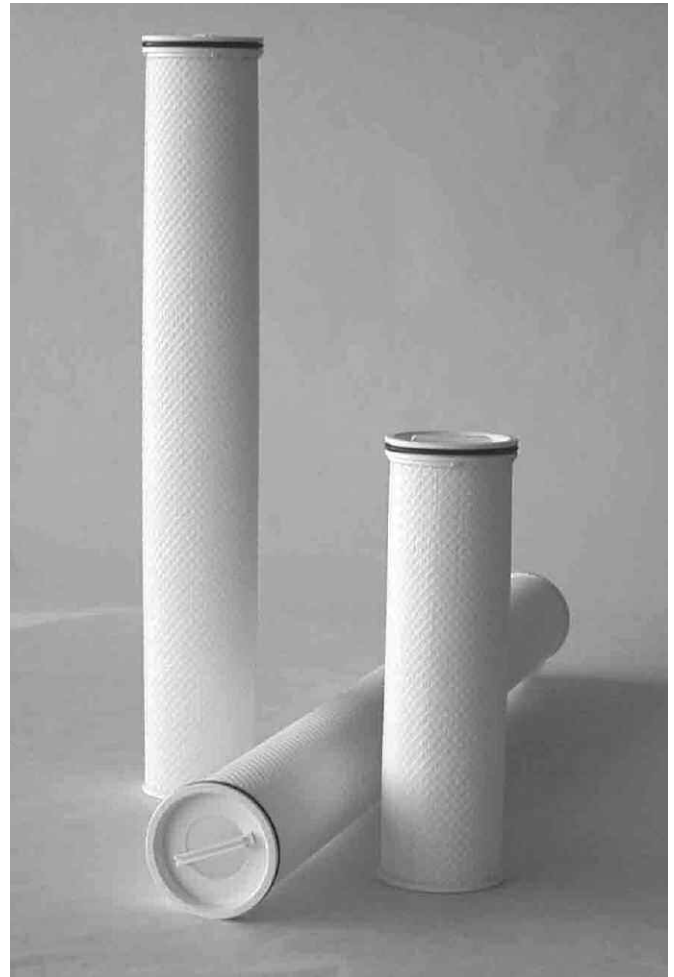

Standard Marksman XLD High Flow filter. Available in 20, 40, and 60 inch lengths.

¹ Maximum flow through the filter element is application dependent. Pall suggests not to exceed 500 gpm (1892 lpm) per 60" element; 333 gpm (1260 lpm) per 40" element; 167 gpm (632 lpm) per 20" element, as good application practice.

² Maximum operating differential pressure recommended for inside to out flow only.

Particle Removal Ratings (µm)³

Grade	≥ 90% Removal (Beta 10)
XLDM1.5	1.5 µm
XLDM 3	3 µm
XLDM 4.5	4.5 µm
XLDM 10	10 µm
XLDM 20	20 µm
XLDM 30	30 µm
XLDM 70	70 µm

³ Removal efficiencies based upon a modified ASTM F795 Dynamic Single Pass Efficiency test.

⁴ Pressure drop in psid per gpm for the cartridge length shown. Multiply this value by the total system flow to determine the aqueous pressure drop. Note, for fluids other than water; multiply this value by the fluids viscosity at the operating temperature in centipoise. This value is the pressure drop across the Marksman XLD High Flow filter(s) only; it must be added to the pressure drop due to the High Flow filter housing. For kPa/lpm, multiply mbard/lpm by 0.1000.

Typical Liquid Flow Specifications

Filter Grade	PSID per 1 GPM (mbard/lpm) - Water @ 68°F (20°C) ⁴		
	20"	40"	60"
XLDM 1.5	0.0278 (0.5058)	0.0139 (0.2529)	0.0093 (0.1686)
XLDM 3	0.0111 (0.2027)	0.0056 (0.1014)	0.0037 (0.0676)
XLDM 4.5	0.0065 (0.1182)	0.0032 (0.0591)	0.0022 (0.0393)
XLDM 10	0.0044 (0.0795)	0.0022 (0.0397)	0.0015 (0.0265)
XLDM 20	0.0017 (0.0308)	0.0008 (0.0154)	0.0006 (0.0103)
XLDM 30	0.0023 (0.0427)	0.0012 (0.0213)	0.0008 (0.0142)
XLDM 70	0.0026 (0.0466)	0.0013 (0.0233)	0.0009 (0.0155)

Part Numbers/Ordering Information

XLDM ■ - ● U-HF ◆ (e.g., XLDM3-20U-HFJ)

Code ■	Filter Grades	Code ●	Cartridge Lengths - nominal (inches/mm)
1.5	1.5 µm		
3	3 µm		
4.5	4.5 µm	20	20/508
10	10 µm	40	40/1016
20	20 µm	60	60/1524
30	30 µm		
70	70 µm		

Code ◆	Seal/O-ring Material
H13	Nitrile O-ring
H13U	Nitrile U-cup
H	Fluorocarbon Elastomer O-ring
HU	Fluorocarbon Elastomer U-cup
J	Ethylene Propylene O-ring
JU	Ethylene Propylene U-cup

Housing Design

Three configurations are available: horizontal, vertical and centerpipe design.

The in-line horizontal configuration eliminates the need for a platform, or ladder, to remove the filters from the housing.

Vertical vessels may be more appropriate when floor space is limited. However, a platform may be needed to easily remove the elements.

In both the standard horizontal and vertical configurations, the inlet pipe is located between the filter element tubesheet and housing lid. The larger the vessel diameter, the longer the distance to reach in and remove the elements from the vessel. In a centerpipe vessel the housing lid is closer to the filter tubesheet. When the lid is opened the filters are easily accessible for installation and removal.

- Designed to the ASME, section VIII, division 1 code
- Maximum differential pressure across tubesheet: 75 psid (5.2 bar) maximum
- Standard housing gasket: spiral wound 304 stainless steel mineral fiber
- Carbon steel exterior surfaces: sandblasted and coated with an inorganic zinc
- Vent and drains: 1 inch FNPT
- Corrosion allowance: 1/8 inch

Housing Ratings

Vessel Material	Tubesheet and Hold Down Plate Material of Construction	Pressure Rating in Psig/Bar @ 140°F / 60°C
Carbon steel	304 stainless steel	275 psig (19.0 bar)
304 stainless steel	304 stainless steel	259 psig (17.9 bar)
304L stainless steel	304L stainless steel	216 psig (14.9 bar)
316 stainless steel	316 stainless steel	261 psig (18.0 bar)
316L stainless steel	316L stainless steel	216 psig (14.9 bar)

Filter Installation and Filter Seal Mechanism

To install a filter element, remove the element hold down plate by lifting it off the locating pins. Lubricate the O-ring on the open-end of the filter with a compatible fluid, and slide the closed end of the filter into the perforated cage, which is welded to the tubesheet. Seat the elements in place by pressing down on the open-end of the filter until the element is snug in the tubesheet. This provides a seal between the filter and housing via the filter O-ring. The open-end cap must be below the tubesheet surface.

After installing all the filter cartridges, reinstall and secure the element hold down plate by guiding it over the locating pins on the tubesheet. The purpose of the hold down plate is to prevent the elements from becoming dislodged in the event of reverse flow.

A filter element tool is provided with each housing to aid with the installation and removal of the filter cartridges. This tool eliminates the need for an operator to reach within the filter vessel to either remove or install the filters.

Figure 1: High Flow Horizontal Housings (Aqueous Housing Pressure Drop - PSID)

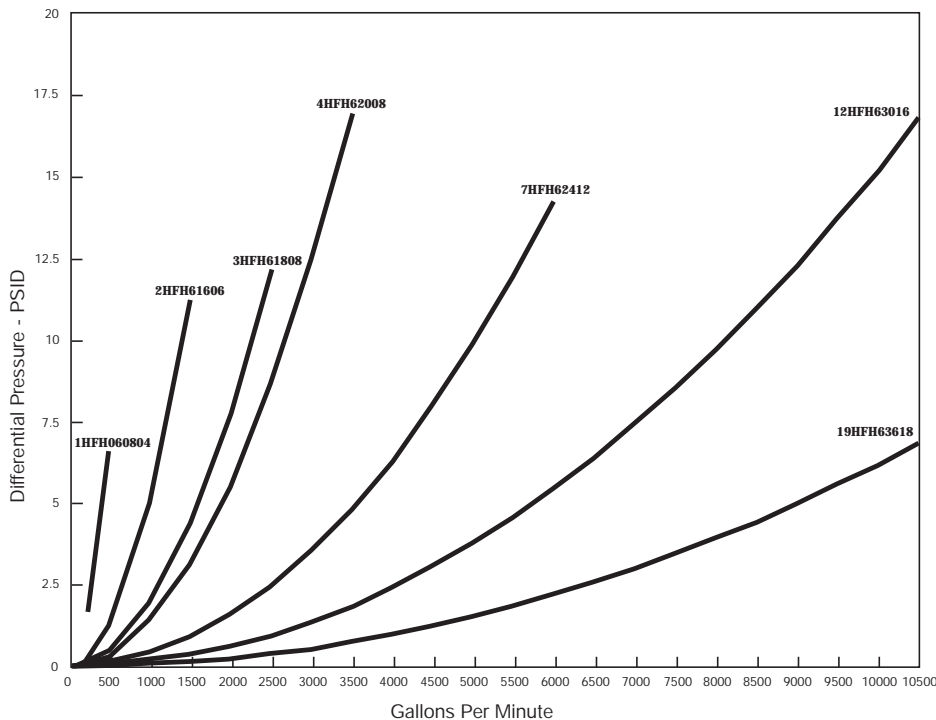

Ordering Information-Standard Horizontal and Vertical Housings

Part Number	No Of Filters	Nominal Housing Diameter (In/mm) (D)	Inlet/Outlet Flange Diameter (In/mm)	Maximum Horizontal Housing Overall Length (In/mm) (L)	Horizontal Housing Height (In/mm) (H)	Distance Between Housing and Lid and Tubesheet (In/mm)	Housing Weight Empty (Lbs/KG)	Housing Weight Full of Water (Lbs/KG)	Housing Cover Swing Opening (In/mm)
1HF ■ ● 0804F1 ▲ ◆	1	9/219	4/102	89/2261	32/817	14.5/368.3	471/214	621/282	9/228.6
2HF ■ ● 1606F1 ▲ ◆	2	16/406	6/152	100/2527	40/1023	22.7/576.3	1172/532	1771/803	25.8/654.6
3HF ■ ● 1808F1 ▲ ◆	3	18/457	8/203	104/2642	43/1093	26.2/665.2	1583/718	2384/1081	27.2/692.8
4HF ■ ● 2008F1 ▲ ◆	4	20/508	8/203	105/2654	46/1175	26.4/669.6	2087/947	3048/1382	29.8/756.3
7HF ■ ● 2412F1 ▲ ◆	7	24/610	12/305	112/2832	59/1487	31.9/809.6	3250/1474	4762/2160	34.2/870.6
12HF ■ ● 3016F1 ▲ ◆	12	30/762	16/406	121/3073	58/1480	38.7/982.7	4670/2118	7306/3314	38.0/964.9
19HF ■ ● 3620F1 ▲ ◆	19	36/914	20/508	129/3264	68/1718	43.4/1101.6	7060/3202	11121/5045	44.8/1138.8

Ordering Information - Horizontal Orientation, Centerpipe Designed Housings

Part Number	No. of Filters	Rated Flow Per Housing- 60" Long Filter GPM/LPM	Nominal Housing Diameter (In/mm) (D)	Inlet/Outlet Flange Diameter (In/mm)	Maximum Horizontal Housing Overall Length (In/mm) (L)	Horizontal Housing Height (In/mm) (H)	Distance Between Housing and Lid and Tubesheet (In/mm)	Housing Weight Empty (Lbs/KG)	Housing Weight Full of Water (Lbs/KG)	Housing Cover Swing Opening (In/mm)
7HF ■ C ● 2808F1 ▲ ◆	7	3500/13248	28/711	8/203	104.3/2648	57/1448	5/124	4056/1840	6229/2825	36/914
8HF ■ C ● 3012F1 ▲ ◆	8	4000/15140	30/762	12/304	117.6/2988	58/1480	6/154	4707/2135	7348/3333	40/1018

Code	Housing Configuration
H	Horizontal
V	Vertical

Code	Housing Metallurgy
285	Carbon Steel Vessel, 304 Stainless Steel Tubesheet
S3	304L Stainless Steel
S8	304 Stainless Steel
L3	316L Stainless Steel
L8	316 Stainless Steel

Code	Nominal Cartridge Length (Inches/mm)
2	20/508
4	40/1016
6	60/1524

Code	Optional Outlet Size ⁵ Horizontal Housings
XU	Upper Outlet Location
XL	Lower Outlet Location

⁵ If the housing is to be used as a prefilter to a horizontal liquid/liquid coalescer, then the vessel should be ordered using the XU or XL option for the outlet location. The orientation of the outlet should be the same as that of the sump on the coalescer. In this way no buildup of coalesced liquid will occur in the prefilter.

Horizontal Housings

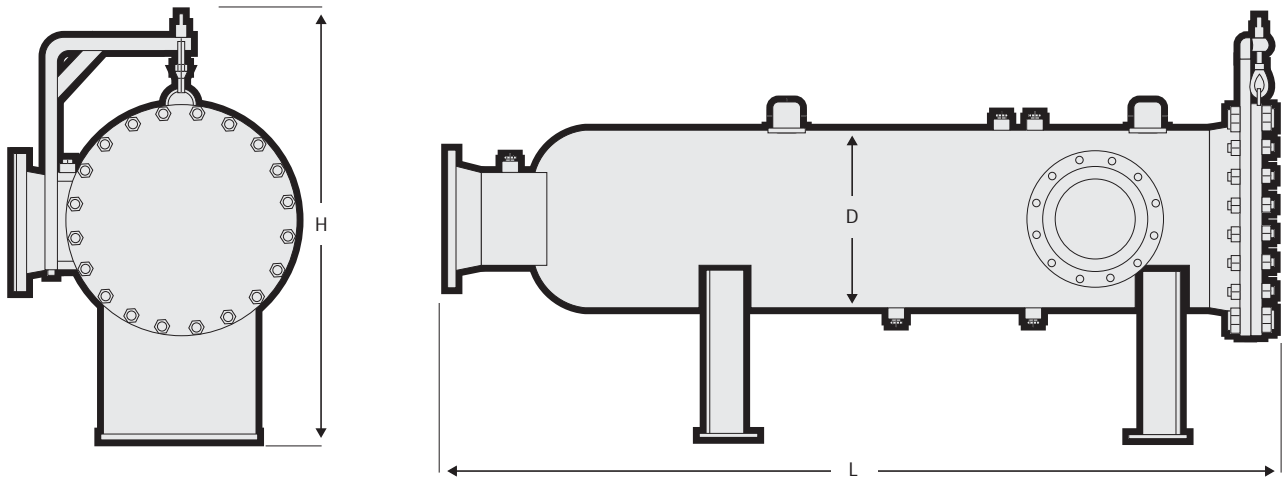

Horizontal Housings, Centerpipe Design

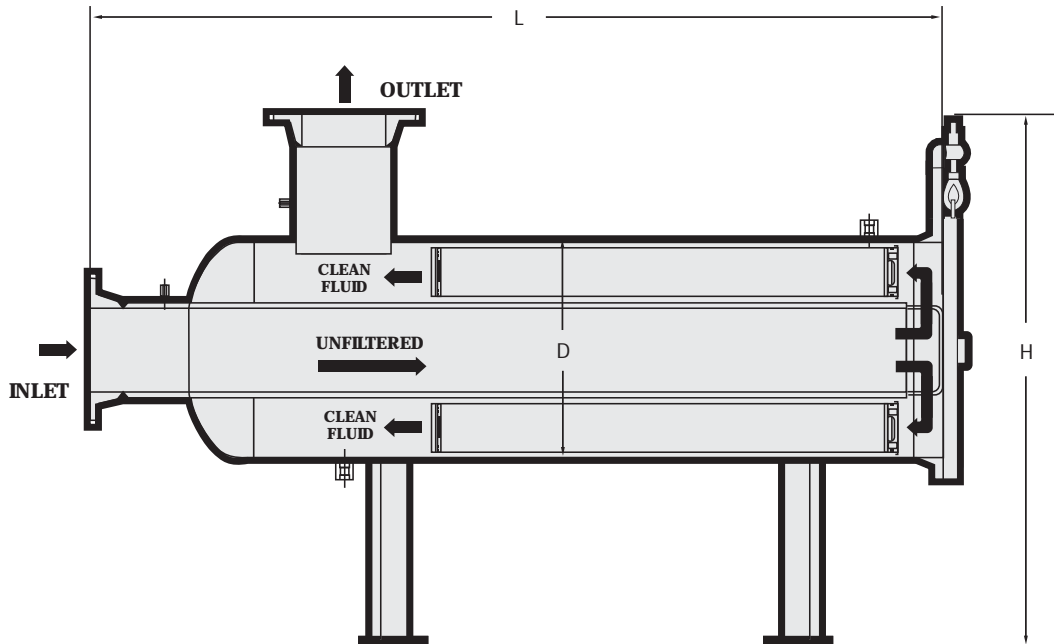

Marksman XLD High Flow Filter System Reduces Costs

Begin reducing your capital and operating costs today. Contact your local Pall distributor, or call Pall directly for a system quotation.



Pall Corporation

25 Harbor Park Drive
Port Washington, NY 11050
+1 516 484 3600 telephone
+1 800 289 7255 toll free US

Portsmouth - UK
+44 (0)23 9230 3303 telephone
+44 (0)23 9230 2507 fax

Visit us on the Web at www.pall.com

Pall Corporation has offices and plants throughout the world. For Pall representatives in your area, please go to www.pall.com/corporate_contact.asp.

Because of technological developments related to the products, systems, and/or services described herein, the data and procedures are subject to change without notice. Please consult your Pall representative or visit www.pall.com to verify that this information remains valid.

© Copyright 2008 Pall Corporation. Pall, , Marksmen, and Poly-Fine are trademarks of Pall Corporation. ® Indicates a Pall trademark registered in the USA.
Filtration. Separation. Solution.sm is a service mark of Pall Corporation.