

Case Study/ Mobile Filter Skid Improves Operation of Amine Unit at Fertilizer Plant



FCMFSEN

Application

A Middle East fertilizer producer operates an amine unit (aMDEA) for CO₂ removal from the gas in the ammonia section. The total inventory of the unit is approximately 2,000 m³.

The problem

Over a number of months, the plant experienced a constant increase in amine carry-over, antifoam usage and amine solution make-up. This resulted in reduced CO₂ absorption efficiency, general loss in production capacity and higher operational costs.

At the same time, the visual appearance of the amine solution progressively turned a dark brown, suggesting a build-up of fine solid particulate contamination in the amine solution. The plant was not able to control solid contamination levels, despite the presence of an existing filter system, rated 10 micron by the original filter supplier.

Foaming issues in amine, Benfield and glycol units and their related consequences, such as excessive antifoam consumption, amine carry-over and excessive volume make-up, frequent replacement of filters, unscheduled shutdowns for cleaning, etc. are well known problems. They are typically related to the uncontrolled solid contamination levels in the amine solution, as solid particles tend to stabilize foam (Raymond, et al., 2010) (Brown Jr & Hashemi, March 1993). Conventional 'nominal rated' filter technologies are unable to maintain a low and consistent solid contamination level.

Pall solution

Pall proposed the installation of a mobile filter skid, on a side stream to the main line, to 'clean-up' or 'depollute' the amine solution from solid contaminants without a shutdown of the unit. The filter skid is equipped with 'absolute' rated High Flow filter cartridges, the performance of which is validated and reproducible.

The objective agreed upon with the plant was to reduce the solid contamination level (Total Suspended Solids content or TSS) to below 5 ppm.

The filter skid is equipped with 'absolute' rated High Flow filter cartridges, the performance of which is validated and reproducible

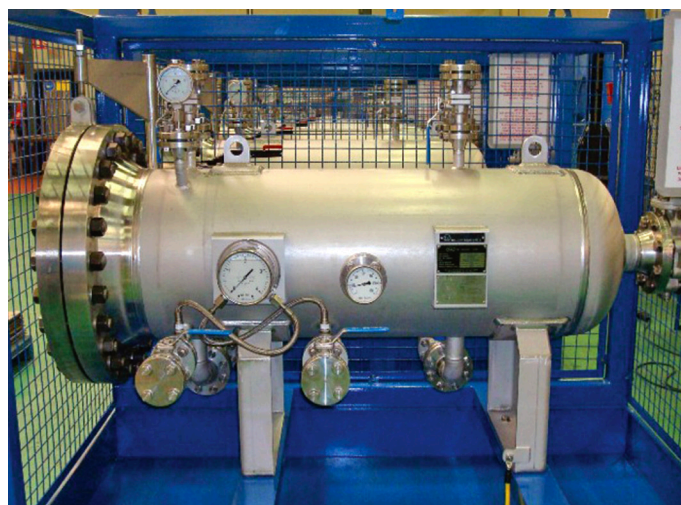

A typical Pall mobile filter skid

The filter skid was connected on a side stream line with flexible hoses, next to the existing filter, with flow rate controlled through the flow control valve (FCV) on the skid (see P&ID below). Operating conditions throughout the depollution were:

- Nominal flow: 60 m³/hr
- Solution T° = 75~78 °C
- Change over DP = 1 Bar g
- Line pressure = 4~7 Bar g

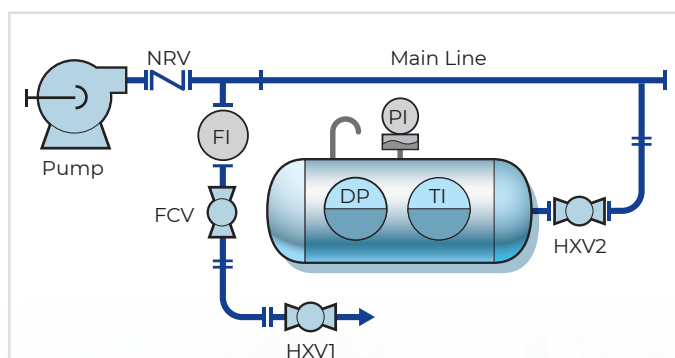

Legend

NRV = Non Return Valve	HXV1 = Inlet Ball Valve
TI = Temperature Indicator	HXV2 = Outlet Ball Valve
DP = Differential Pressure Gauge	FI = Flow Indicator
PI = Pressure Indicator	FCV = Flow Control Valve

Mobile Filter Skid Improves Operation of Amine Unit at Fertilizer Plant



Operating feedback

The depollution of the amine solution was achieved with 15 and 10 micron Nexis® High Flow filter cartridges; then with 10 and 4.5 micron Ultipleat® High Flow filter cartridges. The micron ratings were progressively decreased while the quality of the amine solution was improving. The replacement frequency varied with the filter rating and the progressive clean-up of the amine solution. For instance, the first set of the 15 micron Nexis cartridges was replaced after 24 hours and the third set after 3 days.

The depollution campaign was interrupted once due to a process upset and a second time due to a planned shutdown. After both interruptions, 15 micron Nexis High Flow cartridges were used again due to the increase in the TSS content.

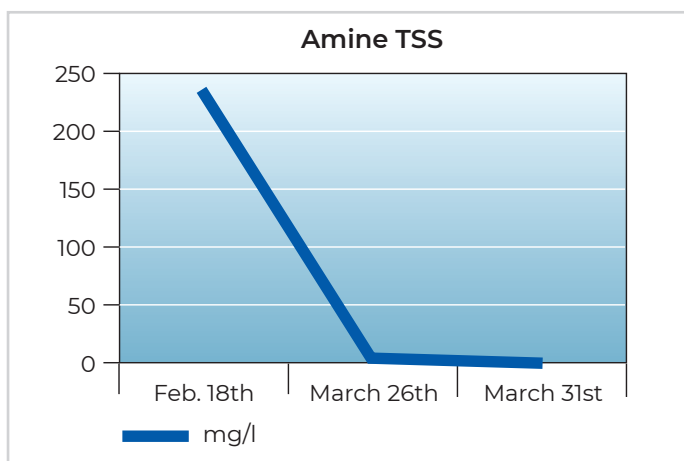

At the start-up of the depollution campaign, the TSS content was 236 ppm. After six weeks of operation, the TSS content reduced to 2 ppm, confirming that the quality requirements were reached and the depollution successfully completed.

Meanwhile, the plant reported that the consumption of antifoam chemicals dropped by about 50%, carry-over was completely stopped and the level of off-spec final

product was decreased from 70 ton per day to zero, resulting in savings of several million dollars per year.

The plant was delighted with the results of the depollution campaign, and they decided to keep the mobile filter skid in operation until a permanent absolute filtration system could be installed.

Savings estimation

The multiple positive impacts linked to the amine quality improvement resulted in the important savings estimated below:

Description	Saved Value/month	Total for 12 months
70 Ton production loss (Ammonia)	\$ 1,100,000	\$ 13,200,000
20 Ton Amine make-up/month	\$ 60,000	\$ 720,000
Direct Maintenance cost/Chemicals injection	\$ 60,000	\$ 720,000
Savings	\$ 1,220,000	\$ 14,640,000

CONCLUSION

Solid contamination must be maintained at low concentrations to avoid foaming issues in amine, Benfield or glycol units. Stable operation of the unit is possible if the solution is filtered efficiently, by means of 'absolute' filter cartridges.

A Pall mobile filter skid equipped with absolute rated, high flow filter cartridges is an efficient and cost-effective solution to help plants recover stable operation of their unit. Importantly, the depollution can be made on-line and does not require any shutdown of the unit.

The mobile filter skid is connected to the process for the duration of the depollution, and it is disconnected once cleanliness requirements are met, or until such time as a permanent solution can be installed.



Corporate Headquarters
Port Washington, NY, USA
+1-800-717-7255 toll free (USA)
+1-516-484-5400 phone

European Headquarters
Fribourg, Switzerland
+41 (0)26 350 53 00 phone

Asia-Pacific Headquarters
Singapore
+65 6389 6500 phone

Visit us on the Web at www.pall.com
Contact us at www.pall.com/contact

Pall Corporation has offices and plants throughout the world. To locate the Pall office or distributor nearest you, visit www.pall.com/contact.

The information provided in this literature was reviewed for accuracy at the time of publication. Product data may be subject to change without notice. For current information consult your local Pall distributor or contact Pall directly.

IF APPLICABLE Please contact Pall Corporation to verify that the product conforms to your national legislation and/or regional regulatory requirements for water and food contact use.

© Copyright 2026, Pall Corporation. Pall and are trademarks of Pall Corporation. ® Indicates a trademark registered in the USA.

FCMFSEN
March 2026

