



Pall Corporation

WS10

WS10 Series Water Sensor



EN

WS10 Operating Instructions

ENGLISH

service instructions

Contents

GENERAL	3
- Warnings, cautions and notes	3
- Safety instructions	3
- Environmental aspects	3
1. PRODUCT DESCRIPTION	4
1.1 General	4
1.2 Dimensions in mm (inch)	4
2. SPECIFICATION	4
3. INSTALLATION	5
3.1 Installation location	5
3.2 Installing the probe directly into the process	5
4. ELECTRICAL CONNECTIONS	5
5. MAINTENANCE	5
5.1 Sensor cleaning	5
5.2 Self-diagnostic and error messages	5
6. ORDERING INFORMATION	5
7. DECLARATION OF CONFORMITY	6
8. TRADEMARKS AND INTELLECTUAL PROPERTY	7
9. WARRANTY, LIMITATION OF LIABILITY	7

Features

The Pall WS10 Series water sensor is an in-line, monitoring solution for measuring dissolved water content in hydraulic, lubricating and insulating fluids. Specifically designed for use in harsh and often remote industrial environments, readings are transmitted continuously to the user's control system as a key component in the predictive maintenance of plant and machinery.

- A sensing probe directly immersed in the fluid to monitor dissolved Water content and temperature
- Water content output in % saturation
- High pressure option up to 100 bar (1450 psi)
- Two analogue outputs, 4–20 mA, for connections to existing SCADA and DCS systems

GENERAL

The manual is a part of the scope of supply and serves to ensure proper handling and optimum function of the instrument. For this reason, the manual must be read before start-up.

In addition, the manual is for all personnel who require knowledge concerning transport, setup, operation, maintenance and repair. The manual must not be used for the purpose of competition without a written consent from Pall and must also not be forwarded to third parties. Copies for personal use are permitted.

All information, technical data and illustrations contained in these instructions are based on information available at the time of publication.

WARNINGS, CAUTIONS AND NOTES

Care must be taken in referring to this manual to ensure adherence with all warnings, cautions and important notes. These carry information related to the safety of personnel and the integrity and satisfactory operation of plant.



WARNINGS: THESE ARE INSTRUCTIONS THAT DRAW ATTENTION TO THE RISK OF INJURY OR DEATH.



CAUTIONS: THESE ARE INSTRUCTIONS THAT DRAW ATTENTION TO THE RISK OF DAMAGE TO THE PRODUCT, THE PROCESS, THE EQUIPMENT OR THE SURROUNDINGS.



IMPORTANT: THESE ARE INSTRUCTIONS THAT DRAW ATTENTION TO INFORMATION THAT WILL AID INSTALLATION, OPERATION OR MAINTENANCE.



Safety instructions

General Safety Instructions

- Excessive mechanical loads and incorrect usage should always be avoided.
- Do not remove the filter cap as the sensor element could be damaged.
- Installation, electrical connection, maintenance and commissioning should be performed by qualified personnel only.



Environmental aspects

At the end of its life, the monitor should be dismantled and disposed of in accordance with all applicable local waste disposal laws and bylaws. Where facilities exist, component parts of the unit may be recycled. Details of the materials of construction are given on the product installation drawing and, if required, more detailed information regarding specific items may be obtained from Pall or an approved agent.

In Europe under the Waste Electrical and Electronic Equipment (WEEE) Directive and implementing regulations, when customers buy new electrical and electronic equipment from Pall they are entitled to:

Send old equipment for recycling on a one-for-one, like-for-like basis (this varies depending on the country). The customer is also entitled to send the new equipment back for recycling when this ultimately becomes waste. Instructions to both customers and recyclers/treatment facilities wishing to obtain disassembly information are provided by following the link below.

www.pall.com/weee

If component parts of the equipment were previously contaminated with the service fluid, an appropriate Manufacturer's Safety Data Sheet (MSDS) for the fluid should be obtained and read to ensure that contaminated component parts are disposed of safely.

1. PRODUCT DESCRIPTION

1.1 General

The Pall WS10 Water sensor was designed for the measurement of water content in oil. WS10 is used for online monitoring of moisture in lubrication or insulation oil, which is very important for the long-term performance and preventive maintenance of plant and machinery. Humidity measurement in oil is similar to the humidity measurement in the air; the actual water content in oil can be indicated by the relative value % RH.

% RH (actual water content expressed as a fraction of the water content in saturated oil) and called percent relative humidity (% RH). % RH = 0 corresponds to completely water-free oil, while % RH = 100 indicates saturated oil. Saturation is the point where oil holds as much water as possible in solution, any further addition of water will result in the presence of droplets of free water. % RH measurement with the WS10 transmitter is based on the outstanding long term stability and resistance to pollution of the capacitive sensor elements.

The WS10 transmitter has two analogue outputs, 4-20mA, for connection to customers existing SCADA and DCS systems. The analogue outputs represent humidity in % RH, and temperature. If oil is cloudy due to free water contamination at the measurement temperature, the WS10 Water Sensor will output a signal that represents 100 % saturation, until steps are taken to bring the water content below the saturation point.

1.2 Dimensions in mm (inch)

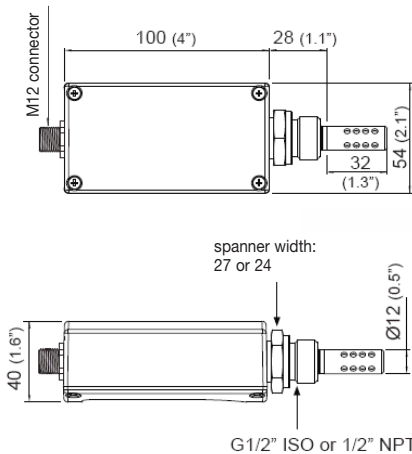

2. SPECIFICATION

Measuring Values

Humidity Sensor

Measuring range: 0...100 % Rh
 Accuracy incl. hysteresis and nonlinearity in air: ± 2.0 % Rh (0...90 % Rh)
 ± 3.0 % Rh (90...100 % Rh)
 Traceable to internal standards, administrated by NIST, PTB, BEV...

Temperature dependence % Rh: $\pm(0.022 + 0.02 \times \% \text{ Rh}) \times \Delta T$ [°C]
 $\Delta T = T - 20$ °C
 $T: \pm(0.0003$ °C/°C)

Temperature Sensor

Working range sensing probe: -25...125 °C (-13...257 °F)

Outputs

Two analogue outputs for 4-20 mA Load <500 Ohm
 % Saturation and Temperature: Out 1 = 0 to 100 %
 Out 2 = -25 °C to 125 °C (-13 °F to 257 °F)

General

Supply voltage: 21...28V DC
 Current consumption at 24V DC: Typically 80mA
 Pressure range: 0...20 bar (0...290 psi) or 0...100 bar (0...1450 psi)
 Housing / Protection class: Al Si 9 Cu 3 / IP65
 Electrical connection: M12 connector
 Fluid temperature range: -40...125 °C (-40...257 °F)
 Electronics temperature range: -40...80 °C (-40...176 °F)
 Storage temperature range: -40...60 °C (-40...140 °F)
 Electromagnetic compatibility: according to EN61326-1, EN61326-2, EN61326-3, FCC Part 15 Class B, Industrial Environment ICES-003 Class B.



3. INSTALLATION

3.1 Installation location

The Water Sensor enclosure is designed in modular form for safe and convenient installation. The M12 connector allows for electrical wiring of the Water Sensor for power and sensor output. Each section of the enclosure fits securely to achieve at least IP65 moisture protection rating. Select a location that offers optimum measuring conditions, the oil must be representative of the system as a whole and must be able to circulate freely around the sensing element. Mount the transmitter directly into the circulating system, in a pipe that is always full of oil. Reservoir mounting is not ideal unless the reservoir residence time is short.

3.2 Installing the probe directly into the process

When installing a probe directly into the process, there should be a stop valve on both sides of the point of installation.

This makes it easy to remove the transmitter for maintenance and calibration.



Step 1: Install the probe with the stop valves closed.

It is not permitted to use a sealing ring with a NPT 1/2" thread. Appropriate PTFE sealing tape or sealant should be used instead.

Step 2: Insert the probe into the process and screw it as tight as possible by hand.

Step 3: If there is a sealing ring, check it for correct centering and tighten the screw connection with a torque of 30 Nm.

4. ELECTRICAL CONNECTIONS

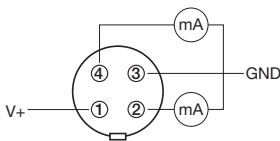

Male connector
 1 V+
 2 output 1
 3 GND
 4 output 2

5. MAINTENANCE

5.1 Sensor cleaning

Cleaning of the measuring head is recommended before use with another fluid and prior to calibration. Do not touch or rub the sensing element during the cleaning process!

Cleaning of sensor from oil residue:

- 1) Immerse only the measuring head in N-HEPTAN and swirl for approx. 30 seconds. Do not use solvents such as acetone.
- 2) Remove excess liquid and allow to air dry for approx. 2 minutes.



Warning:

It is strongly advised NOT to try cleaning the sensor by mechanical means, such as rubbing the sensor with any type of wiper!

5.2 Self-diagnostic and error messages

LED D1 (blue):

- constantly lit => sensor element damaged
- flashing => sensor element bedewed (Wet with free water)

6. ORDERING INFORMATION

Water Sensor P/N: **WS10 S**  

Table 1: Relay Options

Code	Probe Options
B08	½ NPT connector
C08	½ BSPP connector

Table 2: Probe Options

Code	Pressure Options
None	20 bar (290 psi) Standard
H	100 bar (1450 psi) High Pressure

7. DECLARATION OF CONFORMITY



PALL EUROPE

A division of Pall Corporation

DECLARATION OF CONFORMITY

PRODUCT DESCRIPTION:	FIXED INSTALLATION WATER SENSOR
PRODUCT PART NUMBER:	WS10C08, WS10B08, WS10C08H, WS10B08H
SERIAL NUMBER:	SEE NAMEPLATE

On behalf of the Pall Europe division of Pall Corporation, we hereby declare that the above product complies with the following transposed harmonised standards:

BS EN ISO 14121-1:2007	Safety of Machinery – Risk Assessment
EN61326-1: 2006	Electrical equipment for measurement, control and laboratory use – EMC requirements General requirements.
EN61326-2-3: 2006	Electrical equipment for measurement, control and laboratory use. EMC requirements. Test configuration, operational conditions and performance criteria for transducers with integrated or remote signal conditioning
ICES-003 ClassB	This Interference-Causing Equipment Standard sets out the technical requirements relative to the radiated and conducted radio noise emissions from digital apparatus.
FCC Part 15 ClassB	Covers the regulations under which an intentional, unintentional, or incidental radiator can be operated without an individual license.
BSEN60529 : 1992	Degrees of Protection Provided by Enclosures

This compliance is sufficient to meet the requirements of the EC Machinery Directive 98/79/EC, and the Low Voltage Directive 2006/95/EC. This product must be regularly serviced by Pall and /or their approved agent for the declaration to remain effective after shipment.

J.Collard, Engineering 'Projects' Manager

For and on behalf of:

Pall Machinery and Equipment

8. TRADEMARKS AND INTELLECTUAL PROPERTY

The design of this equipment, software and supporting documentation is the intellectual property of Pall Europe Ltd and is subject to copyright.

NOTE: Pall and **(PALL)** are trademarks of Pall Corporation. ® indicates a trademark registered in the USA.

Filtration. Separation. Solution.sm is a service mark of Pall Corporation.

9. WARRANTY, LIMITATION OF LIABILITY

There is no warranty of merchantability or fitness for any particular purpose with respect to any of the products, nor is there any other warranty express or implied, except as provided for herein.

For a period of twelve months from the date of delivery from the Seller or three thousand hours of use, whichever occurs first (the "Warranty Period"), the Seller warrants that products manufactured by the Seller when properly installed and maintained, and operated at ratings, specifications and design conditions, will be free from defects in material and workmanship.

The Seller's liability under any warranty is limited solely (at the Seller's discretion) to replacing (FOB original ship point), repairing or issuing credit for products which become defective during the Warranty Period. The Purchaser shall notify the Seller promptly in writing of any claims and provide the Seller with an opportunity to inspect and test the product claimed to be defective.

Buyer shall provide the Seller with a copy of the original invoice for the product, and prepay all freight charges to return any products to the Seller's factory, or other facility designated by the Seller. All claims must be accompanied by full particulars, including system operating conditions, if applicable.

The Seller shall not be liable for any product altered outside of the Seller's factory except by the Seller or the Seller's authorized distributor, and then, as to the latter, only for products which have been assembled by the distributor in accordance with the Seller's written instructions. Nor shall the Seller be liable for a product subjected to misuse, abuse, improper installation, application, operation, maintenance or repair, alteration, accident or negligence in use, storage transportation or handling.

In no event will the Seller be liable for any damages, incidental, consequential or otherwise, whether arising out of or in connection with the manufacture, packaging, delivery, storage, use, misuse, or non use of any of its products or any other cause whatsoever.

LIABILITY

Pall does not accept warranty and liability claims either upon this publication or in case of improper treatment of the described products.

The document may contain technical inaccuracies and typographical errors.

The content will be revised on a regular basis. These changes will be implemented in later versions. The described products can be improved and changed at any time without prior notice.

Because of developments in technology this data or procedures may be subject to change. Consequently we advise users to review their continuing validity annually. Part numbers appearing in this manual are protected by the Copyright of Pall Europe Limited.

USA

FCC notice:

This equipment has been tested and found to comply with the limits for a Class B digital device, pursuant to part 15 of the FCC Rules. These limits are designed to provide reasonable protection against harmful interference in a residential installation. This equipment generates uses and can radiate radio frequency energy and, if not installed and used in accordance with the installation manual, may cause harmful interference to radio communications. However, there is no guarantee that interference will not occur in a particular installation. If this equipment does cause harmful interference to radio or television reception, which can be determined by turning the equipment off and on, the user is encouraged to try to correct the interference by one or more of the following measures:

- Reorient or relocate the receiving antenna.
- Increase the separation between the equipment and receiver.
- Connect the equipment into an outlet on a circuit different from that to which the receiver is connected.
- Consult the dealer or an experienced radio/TV technician for help.

CAUTION:

Any changes or modifications not expressly approved by the party responsible for compliance could void the user's authority to operate this device.

CANADIAN

ICES-003 notification:

This Device B digital apparatus complies with Canadian ICES-003.



Pall Corporation

Pall Industrial Manufacturing

25 Harbor Park Drive
Port Washington, NY 11050
+1 516 484 3600 telephone
+1 888 333 7255 toll free US

Portsmouth - UK
+44 (0)23 9230 3303 telephone
+44 (0)23 9230 2507 fax

Visit us on the Web at www.pall.com

Pall Corporation has offices and plants throughout the world. For Pall representatives in your area, please go to www.pall.com/contact

Because of technological developments related to the products, systems, and/or services described herein, the data and procedures are subject to change without notice. Please consult your Pall representative or visit www.pall.com to verify that this information remains valid.

© Copyright 2010, Pall Corporation. Pall and  are trademarks of Pall Corporation.
® indicates a trademark registered in the USA. *Filtration. Separation. Solution.sm* is a service mark of Pall Corporation.