

PCC FR Series Component Cleanliness Cabinet

The PCC-FR Cleanliness Cabinet has been specifically developed by Pall to assess the cleanliness level of components or manufactured parts by flushing them out, simulating their functional operation under turbulent flow conditions. This is accomplished by passing a filtered, low viscosity fluid through the component or finished part under turbulent flow conditions to flush contaminants from surfaces and transport them to a test membrane for subsequent analysis.

The PCC-FR enables operators to assess the cleanliness levels of manufactured parts and components in accordance with ISO 18413, ISO16232 and VDA 19 procedures.

Features

- Small footprint and ergonomic design
- Simple to install and operate
- Stainless steel and carbon steel construction
- PLC controlled operation
- Pressurized solvent flushing and recycling circuits
- Programmable flushing, blowing and drying sequence
- Requiring only a power and pressurized air source
- Fitted with adjustable feet, requiring only an electrical power supply and pressurized air source

Principles of Operation

During the test filtered solvent is passed through the component, flushing contaminants downstream and capturing them on an analysis membrane. After passing through the membrane the solvent is filtered to 0.2 µm and then returned to the test component (a re-circulating loop) to continue the flushing procedure.

The flushing process is stopped when the ISO or VDA standard 'End Point' is reached. The overall extraction procedure is finalized with a blowing and drying sequence that ensures both the component and the circuit are entirely free of solvent traces.

General Specifications

- Stainless Steel (primary) flushing circuit
- Control panel with color touch screen
- Monitoring of the key operating parameters
- Solvent filter rating: 0.2 µm absolute
- 2 commutable test membrane holders accessible from the front panel
- Quick (clamp) connection of the component to the flushing circuit by clamps



Pall PCC-FR

For getting effective turbulent flow conditions, the Reynolds (Re) Number must be > 4,000.

Reynolds (Re) Number: A non-dimensional number that provides a qualification of the degree of turbulence within a pipe or hose

The flow conditions in a pipe or a hose can be assessed using Reynolds Number as follows:

$$Re = 21,200 \times Q / (\nu \times d)$$

Q = Flow rate (L/min)

d = Pipe internal diameter (mm)

ν = Kinematic viscosity of fluid in cSt (mm²/s)



Laminar Flow



Turbulent Flow

Laminar Flow: Reynolds Number < 2,000

Transitional Flow: Reynolds Number 2,000 - 4,000

Turbulent Flow: Reynolds Number > 4,000

Examples of simple applications

Flow Rate (L/min)	Pipe Diameter (mm)	Re
2	5	4,240
10	25	4,240
20	50	4,240

Technical information

Dimensions :	1130 x 850 x 1060 mm (44.5 x 33.5 x 41.7 inch)
Weight :	350 kg (771.6 lb)
Materials :	304 L stainless steel
Seals:	Fluorocarbon
Power supply :	220-240 V - 50/60 Hz, single phase
Power consumption :	1500 W
Flushing Flowrate:	Adjustable - see range in Table 1
Flushing Pressure:	4.5 bar max (65 psi) (adjustable)

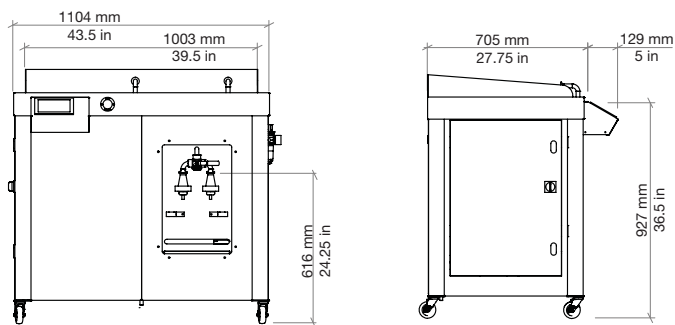

The PCC FR series cabinets meet the requirements of the European 2006/42/EC Directive and are CE marked

Ordering information

Component Cleanliness Cabinet

PCC FR 1 2

Table 1: PCC Flow Capacity

Code	Flow Range
1	2 L/min max
2	10 L/min max
3	20 L/min max

Table 2: PCC Options

Code	Description
1	Standard cabinet
2	Additional circuit for external solvent dispensing pen and draining line

Accessories

FR 3

Table 3: Accessories

Code	Description
M	2Ø 90 mm membrane holders

For any other definition or application, do not hesitate to contact us

Design it
Build it
Keep it

CLEAN



Pall Corporation

Pall Machinery and Equipment

25 Harbor Park Drive
Port Washington, NY 11050
+1 516 484 3600 telephone
+1 800 289 7255 toll free US

Portsmouth - UK
+44 (0)23 9230 3303 telephone
+44 (0)23 9230 2507 fax
industrialeu@pall.com

Filtration. Separation. Solution.SM



ENABLING A
GREENER
FUTURESM

Visit us on the Web at www.pall.com

Pall Corporation has offices and plants throughout the world. For Pall representatives in your area, please go to www.pall.com/contact

Because of technological developments related to the products, systems, and/or services described herein, the data and procedures are subject to change without notice. Please consult your Pall representative or visit www.pall.com to verify that this information remains valid.

© Copyright 2011, Pall Corporation. Pall and are trademarks of Pall Corporation. ® indicates a trademark registered in the USA. ENABLING A GREENER FUTURE and *Filtration. Separation. Solution.SM* are service marks of Pall Corporation.

M&EPCCFREN

Printed in the UK.

Oct 2011