



Pall Corporation

UH210

UH210 Series

service instructions



EN

UH210 Service Instructions

ENGLISH

M&ESIUH210EN

Filtration. Separation. Solution.SM

1 Specifications

Housing materials:

Head and Cover:	Ductile cast iron
Tube:	Carbon Steel
Cage:	Stainless Steel

Maximum operating pressure:

414 bar (6,000 psi)

Proof pressure:

620 bar (9,000 psi)

Minimum burst pressure:

1500 bar (21,750 psi)

Element burst pressure:

UE210 element 10 bard (150 psid) differential minimum

Operating temperature range:

-29°C to 120°C (-20°F to 250°F) with fluorocarbon seals for petroleum based and specified synthetic fluids
60°C (140°F) maximum in HWCF, water-oil emulsion or water glycol

Bypass valve setting options:

4.5 ± 0.5 bard (65 ± 7 psid) cracking pressure

Non bypass

CAUTION:

Maximum surge flow should not exceed 1.3 times normal flow.

Seals:

Fluorocarbon

The actual operating conditions should be checked by the user to ensure that the element, housing and all seals are compatible with the fluid and application, and are within local safety codes. Please contact Pall or an approved distributor if further information is required.

2 Receipt of equipment

The filter housing, and any optional equipment, are packed individually for assembly by the customer. Unpack carefully and ensure optional items are not mislaid in packaging to be discarded.

3 General sources of information

- For dimensions, operating parameters, assembly/element part number, ordering information, notes, performance data and specifications refer to datasheet M&EUH210EN.
- This equipment has been assessed in accordance with the guidelines laid down in the European Pressure Directive 97/23/EC and has been classified within sound engineering practice S.E.P. We hereby declare the equipment meets the requirements of article 3, section 3, thus meeting the directive requirements. Under the provisions of this directive the filter assembly is suitable for use with group 2 fluids only.
- Where under reasonably foreseeable conditions, including external fires, the allowable limits could be exceeded, suitable protective devices must be installed by the customer within the connecting fluid system.

4 Installation of housing

- The filter can be installed in any attitude, but for ease of servicing, it is recommended that it be installed vertically with the filter tube and cover pointing upwards (UH210) or with the filter tube and cover pointing downwards (UH210).
- The minimum clearance required for element removal is as follows:
 - UH210 series (cover service): 147mm (5.8in) for length 4, 248mm (9.8in) for length 8, 383mm (15.1in) for length 13 and 553mm (21.8in) for length 20 housings.
 - UH210 series (head service): 81mm (3.2") for all lengths.
 - The UH210 Housing is supplied without a filter element. For element installation and servicing procedures, refer to Section 7.
- Threaded differential pressure devices, when fitted, must be torque tightened to 40 lb/ft or 54 Nm. All visual indicators must be clearly visible

NOTE: The UH210 head is supplied with a machined differential pressure warning device port, fitted with a plastic shipping plug. If no differential pressure warning device is ordered, the shipping plug must be removed and replaced with a 'B' type blanking plug (HA9000A104Z) AND torque tightened to 40lb/ft /54Nm.
NOTE: Never place the port plug in this port without first installing uniform size -014 O-ring in lower O-ring groove, otherwise a small bypass flow will result, allowing contaminant downstream of the filter element.

CAUTION:

Never operate the filter unless the warning device port is sealed.

- Mount the filter assembly in position using four 7/16"-14 ('A' and 'E' ports) or M10 x 1.5 ('C' and 'G' ports) bolts in the holes on the head mounting pads. Torque bolts to 9-19 lb/ft or 12-26 Nm.
- Use a check valve downstream of the filter if there is a possibility of reverse flow.
- Install the filter housing using additional piping/valving to allow complete filter assembly bypass if filter maintenance is required without system shutdown. This series is not available in a duplex or service bypass configuration.

CAUTION:

Reverse flow through filter element will cause damage.

NOTE: Piping supports should be provided as close as is practicable to the port connections in order to minimize external loads. This filter assembly must not be electronically isolated from the users earthing system. This filter assembly must be earthed by connecting the users earthing system to one of the inlet/outlet connections.

- Connect lines or hoses to housing inlet and outlet ports.

WARNING:

USE FITTINGS OR ADAPTORS COMPATIBLE WITH PORTS SUPPLIED AS SHOWN BY PART NUMBER ON NAMEPLATE AND NOTED IN DATA SHEETS: USE OF INCORRECT FITTINGS OR ADAPTORS CAN CAUSE FILTER HOUSING OR MANIFOLD FAILURE RESULTING IN LOSS OF PRESSURE AND POSSIBLE SYSTEM FAILURE OR PERSONAL INJURY.

Note: Painting of the filter housing is optional. The coating on the filter housing is a suitable painting base. Cover the differential pressure warning device and nameplate if painting of the housing takes place.

- 4.8 Bleed the filter.
- 4.8.1 UH210 series (cover service): Bleed the filter by opening the vent plug (7) at the top of filter one and one half turns. Jog system and fill filter until all air bleeds through the plug, then torque tighten the vent plug to 12 lb/ft or 16Nm.
- 4.8.2 UH210H series (head service): Bleed the filter by opening the blanking plug (6b) one and one-half turns. Jog system and fill filter until all air bleeds through the plug, then torque tighten the blanking plug to 12 lb/ft or 16 Nm .

Pressurize system fully and check for leaks; if leaks occur refer to section 5.

CAUTION:

Failure to bleed the filter housing adequately will increase the dissolved air content of the system fluid which will shorten fluid life and may cause other problems in the system.

5 Routine maintenance

- 5.1 Pall filters do not normally require special attention except for periodic monitoring of the differential pressure warning device. Schedule replacement of filter element every six months or sooner, and have ample supply of spare elements available.
- 5.2 If external leakage is noted, replace O-ring at leak. If leakage persists, check sealing surfaces for scratches or cracks; replace any defective parts.
- 5.3 Differential pressure devices actuate when the element needs changing or because of high fluid viscosity in 'cold start' conditions. If 'cold start' conditions exist, see Section 6.2 and 6.3.
- 5.4 A dirty system can quickly plug a new filter element, especially with Pall high efficiency filter media. It may require one or two initial element changes to stabilize element life. If element life is short or differential pressure is excessive, filter may be undersized; refer to the sizing and selection section of the product literature or contact your local Pall representative.
- 5.5 Make sure element change labels are clean and undamaged. Replace illegible labels with the appropriate new labels.

6 Differential pressure devices

Reference should be made to product literature for dimensions, operating parameters, part numbering, ordering information and specifications.

- 6.1 Differential pressure devices actuate when the element needs changing or because of high fluid viscosity in 'cold start' conditions.
- 6.2 If stainless steel visual indicator is fitted and actuates during 'cold start' (red button extends 5mm, 3/16"), reset by depressing the button when the normal operating temperature is reached. If indicator actuates after resetting, replace element. If brass indicator

is fitted and actuates during 'cold start' (flag inside indicator changes from white to red), it will automatically reset when the normal operating temperature is reached. If indicator is still actuated after normal operating temperature is reached, replace element.

NOTE: Option 'P' visual indicator has thermal lockout and manual reset. No signal below 0°C (32°F), signal above 29°C (80°F).

- 6.3 If the electrical switch actuates (e.g. red light comes on) during cold start, continue operating until the signal (red light) goes out as system warms to normal operating temperature. This feature can be used as 'warm up' indication in operating procedures. If the warning signal (red light) remains or appears when system is warm, replace the filter element.
- 6.4 Use of both positive indication (green light) and negative indication (red light for blocked element) is recommended to effectively monitor filter element life.

Electrical connections and ratings are dependent on indicator chosen. Typical values only are shown below:

110 VAC =	4A (inductive)
	4A (resistive)
220 VAC =	4A (inductive)
	4A (resistive)
28 VDC =	3A (inductive)
	5A (resistive)
48 VDC =	1A (inductive)
	1.5A (resistive)
125 VDC =	0.25A (inductive)
	0.5A (resistive)
Maximum in-rush	24 amps

Underwriter's lab. Inc. listed ratings of pressure switch (Microswitch) options are:

4 amps at 250 VAC
0.25 amp resistive at 220 VDC
0.50 amp resistive at 110 VDC

Electrical differential pressure switch option:

When preset differential pressure is exceeded continuity switches from Normally Closed (NC) - Common to Normally Open (NO) - Common

When differential pressure decreases below the pre-set value, continuity returns from Normally Open (NO) - Common to Normally Closed (NC) - Common

Figure 1a - Stainless Steel Switch Circuit Diagram

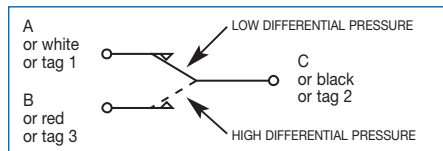
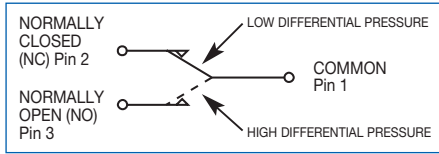

Figure 1b - Brass Switch Circuit Diagram



See individual indicator options for connection details.

7 Filter element installation / servicing

During servicing, the external surfaces of the filter assembly must be cleaned to remove any dust deposits.

Servicing must be conducted using suitable tools that do not present a hazard.

Servicing must not be carried out when a potentially explosive atmosphere is present.

CAUTION:

Filter elements should be replaced upon indication or at specified intervals, six months maximum. Failure to change the element will cause the filter to go on bypass.

Refer to Service Parts List (Section 9) for item numbers for applicable replacement element series. Remove and replace element as follows:

7.1 Turn off and depressurize the system.

WARNING:

FAILURE TO DEPRESSURIZE THE FILTER BEFORE SERVICING ELEMENT COULD RESULT IN EXPLOSIVE LOSS OF FLUID, DAMAGE TO EQUIPMENT AND POSSIBLE PERSONAL INJURY.

7.1.1 For UH210 series (cover service):

Open the vent plug (7) at the top of the filter one and one-half turns. Open partially the blanking plug (6b) in the filter head and drain fluid into a suitable waste receptacle. This sequence may be long for high viscosity fluids. Replace and torque tighten the blanking plug to 12ft/lb or 16Nm. Unscrew and remove cover (3) from tube (2) counter-clockwise when viewed from above. It will be necessary to use a 1" socket wrench on the hexagon on the cover (3) to loosen the cover initially

Note: The UH210 series assembly is equipped with Pall's 'Auto-Pull' element extraction mechanism to facilitate element removal. While removing the cap, tabs on the element endcap lock into hooks in the cap and the element is automatically pulled from the nipple.

7.1.2 For UH210H series (head service):

Open the drain plug (7) at the bottom of the bowl assembly (tube and cover) and drain fluid from the bowl into a suitable waste receptacle. Replace and torque tighten drain plug to 12 ft/lb or 16Nm. Unscrew and remove the bowl assembly (2 and 3) from head (1) counter-clockwise when viewed from below. It will be necessary to use a 1" socket wrench on the hexagon on the cover (3) to loosen the cover initially.

- 7.2 Element replacement (UE210 Series): Remove filter element (8), if already fitted, and carefully inspect the interior surface (flow through the element is in-to-out) for visible contamination. Normally no dirt should show, but visible dirt or particles can be an early warning of system component failure. Discard both the filter element and its O-ring. The filter element is NOT CLEANABLE. Any attempt to clean the filter element can cause degradation of the filter medium and allow contaminated fluid to pass through the filter element.
- 7.3 DO NOT run the system without a filter element installed. For UH210C series: check that the O-ring (4) between the cover (3) and tube (2) is not damaged. For UH210H series: check that the O-ring (5) between the tube (2) and head (1) is not damaged.

WARNING:

DO NOT ATTEMPT TO CLEAN OR RE-USE THE ELEMENT. ONLY USE GENUINE PALL REPLACEMENT FILTER ELEMENTS. USE OF SUBSTITUTE ELEMENTS MAY INVALIDATE PRODUCT WARRANTY.

Use the replacement filter as indicated by the part number on the element endcap.

- 7.4 Lubricate element O-ring with clean system fluid. Reinstall element in the shell assembly. Lightly lubricate cover-to-head or tube-to-head (as applicable) O-ring with clean system fluid and reassemble the housing until thread bottoms. The cover or tube should be torque tightened using a suitable socket wrench to 77 ft/lb or 105Nm. O-ring sealing is not improved by over tightening
- 7.5 Bleed the filter by filling the filter until all air bleeds through the vent plug (7), then torque tighten the vent plug to 12 lb/ft or 16Nm. Check for leaks as per section 4.8.
- 7.6 After element change ENSURE DIFFERENTIAL PRESSURE DEVICE IS RESET . Brass visual and electrical and stainless steel electrical switches reset automatically. When system reaches normal operating temperature, check that the electrical switch and/or visual indicator has not actuated. If visual indicator actuates due to a cold start condition, reset again as per section 6.

8 Warranty, Limitation of Liability and Remedies

THERE IS NO WARRANTY OF MERCHANTABILITY OR FITNESS FOR ANY PARTICULAR PURPOSE WITH RESPECT TO ANY OF THE PRODUCTS, NOR IS THERE ANY OTHER WARRANTY EXPRESS OR IMPLIED, EXCEPT AS PROVIDED FOR HEREIN.

For a period of twelve months from the date of delivery from Seller or three thousand hours of use, whichever occurs first (the "Warranty Period"), Seller warrants that products manufactured by Seller when properly installed and maintained, and operated at ratings, specifications and design conditions, will be free from defects in material and workmanship. By way of explanation and not limitation, the Seller does not warrant the service life of the filter element as this is beyond the Seller's control and depends upon the condition of the system into which the filter is installed.

Seller's liability under any warranty is limited solely (in Seller's discretion) to replacing (FOB original ship point), repairing or issuing credit for products that become defective during the Warranty Period. Purchaser shall notify Seller promptly in writing of any claims and provide Seller with an opportunity to inspect and test the product claimed to be defective. Buyer shall provide Seller with a copy of the original invoice for the product, and prepay all freight charges to return any products to Seller's factory, or other facility designated by Seller. All claims must be accompanied by full particulars, including system operating conditions, if applicable.

Seller shall not be liable for any product altered outside of the Seller's factory except by Seller or Seller's authorized distributor, and then, as to the latter, only for products which have been assembled by the distributor in accordance with Seller's written instructions. Nor shall Seller be liable for a product subjected to misuse, abuse, improper installation, application, operation, maintenance or repair, alteration, accident or negligence in use, storage transportation or handling.

In no event will Seller be liable for any damages, incidental, consequential or otherwise, whether arising out of or in connection with the manufacture, packaging, delivery, storage, use, misuse, or non use of any of its products or any other cause whatsoever.

9 Parts List

List	Description	Quantity
1	Head	1
2	Tube	1
3	Cover	1
4, 5	O-ring (cover-to-tube and head-to-tube)	2
6, 6b	Indicator or port plug kit (not shown)	2
7	Vent/drain plug	1
8	Filter element	1

Figure 2

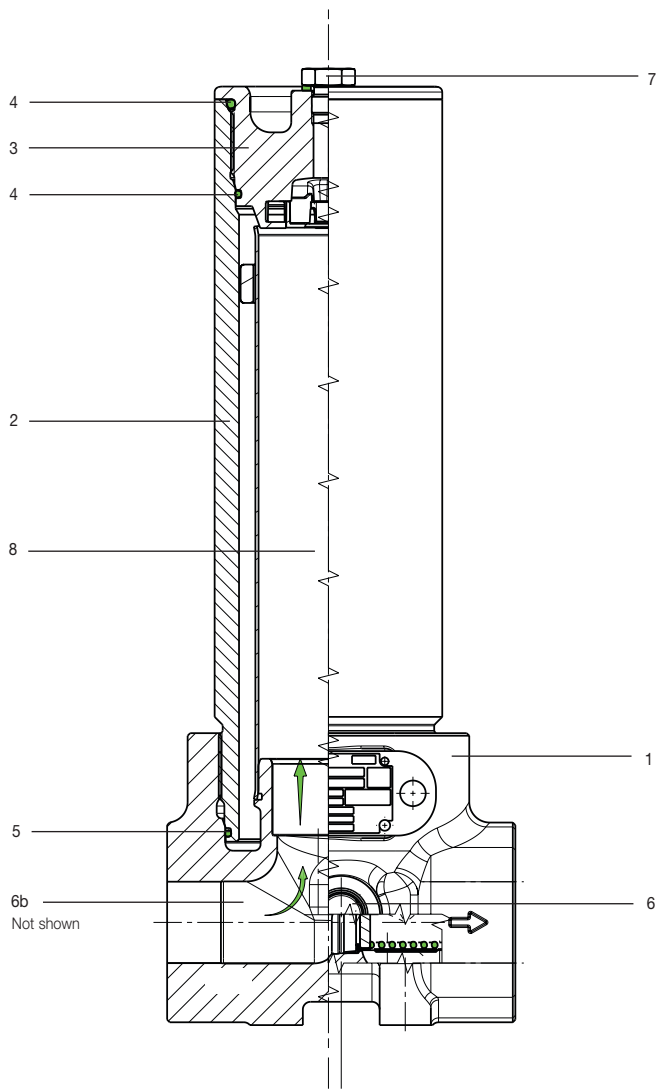
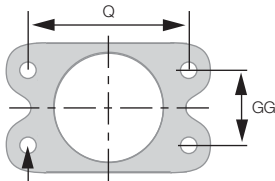

Figure 3



- Z
- 4 HOLES FULL THREAD DEPTH AA
- 4 Gewindebohrungen mit Gewindetiefe AA
- 4 huller med gevind, dybde AA
- 4 taladros pasantes roscados. Profundidad AA
- 4 täyskierteistä reikää, syvyys AA
- 4 trous taraudés de profondeur AA
- 4 fori completamente filettati profondità AA
- 4 tappaten (met draad over volle diepte)
- 4st fästhål. Gänga "Z". Min gängdjup "AA"

Flange Connection Details

Flange Code	Nominal Tube Size	GG	Q	Z Thread	AA
E16	1"	1.093"	2.250"	7/16" - 14 UNC	0.87"
G16	1"	27.8 mm	57.2 mm	M12 x 1.75	22 mm
E20	1 1/2"	1.250"	2.625"	1/2" - 13 UNC	0.75"
G20	1 1/2"	31.8 mm	66.7 mm	M12 x 1.75	19 mm

UH210

HIGH PRESSURE FILTERS

UH210 Series

service instructions



Pall Corporation

25 Harbor Park Drive
Port Washington NY 11050
+1 516 484 3600 telephone
+1 800 289 7255 toll free US

Portsmouth - UK
+44 (0)23 9233 8000 telephone
+44 (0)23 9233 8811 fax
industrial.eu@pall.com



Visit us on the Web at www.pall.com

Pall Corporation has offices and plants throughout the world. For Pall representatives in your area, please go to www.pall.com/contact

Because of technological developments related to the products, systems, and/or services described herein, the data and procedures are subject to change without notice. Please consult your Pall representative or visit www.pall.com to verify that this information remains valid.

© Copyright 2015, Pall Corporation. Athalon, Pall and  are trademarks of Pall Corporation.

® Indicates a trademark registered in the USA. Better Lives. Better Planet and *Filtration. Separation. Solution.SM* are service marks of Pall Corporation.

Filtration. Separation. Solution.SM

December 2015. Printed in England. M&ESIUH210EN