



Pall Corporation

UR619/699

UR619/699 Series

service instructions



EN

UR619/699 Service Instructions

ENGLISH

1371630

PME SI UR619/699

Filtration. Separation. Solution.SM

UR619/699

RETURN LINE FILTERS

1 Specifications

Housing materials:

Head and Tube: Cast/aluminium alloy
Cover: Cast iron

Maximum operating pressure:

28 bar (400 psi)

Proof pressure:

42 bar (609 psi)

Minimum burst pressure:

164 bar (2380 psi)

Element burst pressure:

UE619 element 10 bar (150 psid) differential minimum

Operating temperature range:

-29°C to 120°C (-20°F to 250°F) with fluorocarbon seals for petroleum based and specified synthetic fluids.
60°C (140°F) maximum in HWCF, water-oil emulsion or water glycol

Bypass valve setting options:

1.7 ± 0.3 bar (25 ± 5 psid) cracking pressure
3.4 ± 0.3 bar (50 ± 5 psid) cracking pressure
Non bypass

CAUTION:

Maximum surge flow should not exceed 1.3 times normal flow.

Seals:

Fluorocarbon

The actual operating conditions should be checked by the user to ensure that the element, housing and all seals are compatible with the fluid and application, and are within local safety codes. Please contact Pall or an approved distributor if further information is required.

2 Receipt of equipment

The filter housing, and any optional equipment, are packed individually for assembly by the customer. Unpack carefully and ensure optional items are not mislaid in packaging to be discarded.

3 General sources of information

- 3.1 For dimensions, operating parameters, assembly/element part number, ordering information, notes, performance data and specifications refer to datasheet PMEUR619 or PMEUR699.
- 3.2 This equipment has been assessed in accordance with the guidelines laid down in the European Pressure Directive 97/23/EC and has been classified within sound engineering practice S.E.P. We hereby declare the equipment meets the requirements of article 3, section 3, thus meeting the directive requirements. Under the provisions of this directive the filter assembly is suitable for use with group 2 fluids only.
- 3.3 Where under reasonably foreseeable conditions, including external fires, the allowable limits could be exceeded, suitable protective devices must be installed by the customer within the connecting fluid system.

UR619/699 Series

service instructions

4 Installation of housing

- 4.1 The filter can be installed in any attitude, but for ease of servicing, it is recommended that it be installed vertically with the filter tube and cover pointing upwards.
- 4.2 The minimum clearance required for element removal is as follows:
 - 4.2.1 443mm or 17.5" for length 20 and 951mm or 37.5" for length 40 assemblies.
 - 4.2.2 The UR619/UR699 Housing is supplied without a filter element. For element installation and servicing procedures, refer to Section 7.
- 4.3 Threaded differential pressure devices, when fitted, must be torque tightened to 30-33 ft/lb or 40-45 Nm. All visual indicators must be clearly visible

NOTE: The UR619/UR699 housing is supplied with two machined differential pressure warning device ports, one fitted with a blanking plug, the other with a plastic shipping plug. If no differential pressure warning device is ordered, the shipping plug must be removed and replaced with a 'B' type blanking plug (P/N HA9000-P8-Kit Z) and torque tightened to 40 ft/lb /54 Nm. **NEVER:** Never place the port plug in this port without first installing uniform size -O14 O-ring in lower O-ring groove, otherwise a small bypass flow will result, allowing contaminant downstream of the filter element.

CAUTION:

Never operate the filter unless both warning device ports are sealed.

- 4.4 Mount the filter assembly in position using the mounting bracket kit (13) (if provided). Brackets require four .375" (10mm) bolts each.
 - 4.4.1 UR619 - Four additional mounting holes with 1/2-13UNC threads are provided at the inlet port for mounting the assembly, using the appropriate gasket, to the top of a reservoir or manifold.
 - 4.4.2 UR699 - Mount the filter assembly using the four Ø.531" (13.5 mm) mounting holes.
 - 4.4.3 Torque bolts to: 16 lb/ft (22 Nm) minimum for .375" (10mm) size bolts, and 39 lb/ft (53 Nm) minimum for .500" (12mm) size bolts.
- 4.5 Use a check valve downstream of the filter if there is a possibility of reverse flow.
- 4.6 Install the filter housing using additional piping/valving to allow complete filter assembly bypass if filter maintenance is required without system shutdown.

CAUTION:

Reverse flow through filter element will cause damage.

NOTE: Piping supports should be provided as close as is practicable to the port connections in order to minimize external loads. This filter assembly must not be electronically isolated from the users earthing system. This filter assembly must be earthed by connecting the users earthing system to one of the inlet/outlet connections.

- 4.7 Connect lines or hoses to housing inlet and outlet ports.

WARNING:

USE FITTINGS OR ADAPTORS COMPATIBLE WITH PORTS SUPPLIED AS SHOWN BY PART NUMBER ON NAMEPLATE AND NOTED IN DATA SHEETS: USE OF INCORRECT FITTINGS OR ADAPTORS CAN CAUSE FILTER HOUSING OR MANIFOLD FAILURE RESULTING IN LOSS OF PRESSURE AND POSSIBLE SYSTEM FAILURE OR PERSONAL INJURY.

Note: Painting of the filter housing is optional. The coating on the filter housing is a suitable painting base. Cover the differential pressure warning device and nameplate if painting of the housing takes place.

- 4.8 Bleed filter by opening the vent plug (10) on the cover (5) of the filter one and one half turns. Jog system and fill filter until all air bleeds through the plug (filter can be optionally filled using the fill port (12)), then tighten plug. Pressurize system fully and check for leaks; if leaks occur refer to section 5.

CAUTION:

Failure to bleed the filter housing adequately will increase the dissolved air content of the system fluid which will shorten fluid life and may cause other problems in the system.

5 Routine maintenance

- 5.1 Pall filters do not normally require special attention except for periodic monitoring of the differential pressure warning device. Schedule replacement of filter element every six months or sooner, and have ample supply of spare elements available.
- 5.2 If external leakage is noted, replace O-ring at leak. If leakage persists, check sealing surfaces for scratches or cracks; replace any defective parts. Body assembly is permanently assembled at the factory: do not attempt to disassemble the head (1), body tube (2), or center post (3).
- 5.3 Differential pressure devices actuate when the filter element (8) needs changing or because of high fluid viscosity in 'cold start' conditions. If 'cold start' conditions exist, see Section 6.2 and 6.3.
- 5.4 A dirty system can quickly plug a new filter element, especially with Pall high efficiency filter media. It may require one or two initial element changes to stabilize element life. If element life is short or differential pressure is excessive, filter may be undersized; refer to the sizing and selection section of the product literature or contact your local Pall representative.
- 5.5 Make sure element change labels are clean and undamaged. Replace illegible labels with the appropriate new labels.

CAUTION:

Continued operation of 619/699 series bypass filters (valve options A and B), with differential pressure device actuated, can allow unfiltered flow downstream. Continued operation of 619/699 series non-bypass filters (valve options W, Y, N or 1) May cause collapse or premature fatigue failure of the plugged filter element, which could allow contaminant and unfiltered flow downstream. Refer to element change instructions in section 7.

6 Differential pressure devices

Reference should be made to product literature for dimensions, operating parameters, part numbering, ordering information and specifications.

- 6.1 Differential pressure devices actuate when the element needs changing or because of high fluid viscosity in 'cold start' conditions.
- 6.2 If visual indicator is fitted and actuates during 'cold start' (red button extends 5mm, 3/16"), reset by depressing the button when the normal operating temperature is reached. If indicator actuates after resetting, replace element.

NOTE: Option 'P' visual indicator has thermal lockout and manual reset. No signal below 0°C (32°F), signal above 29°C (80°F).

- 6.3 If the electrical switch actuates (e.g. red light comes on) during cold start, continue operating until the signal (red light) goes out as system warms to normal operating temperature. This feature can be used as 'warm up' indication in operating procedures. If the warning signal (red light) remains or appears when system is warm, replace the filter element.
- 6.4 Use of both positive indication (green light) and negative indication (red light for dirty element) is recommended to effectively monitor filter element life.

Electrical connections and ratings for all differential pressure switch options:

110 VAC	=	4A (inductive), 4A (resistive)
220 VAC	=	4A (inductive), 4A (resistive)
28 VDC	=	3A (inductive), 5A (resistive)
48 VDC	=	1A (inductive), 1.5A (resistive)
125 VDC	=	0.25A (inductive), 0.5A (resistive)

Maximum inrush - 24 amps.

Underwriter's lab. Inc. listed ratings of pressure switch (Microswitch) options are:

- 4 amps at 250 VAC
- 0.25 amp resistive at 220 VDC
- 0.50 amp resistive at 110 VDC

Electrical differential pressure switch operation:

When preset differential pressure is exceeded continuity switches from 'C' - 'A' to 'C' - 'B'.

When differential pressure decreases below the pre-set value, continuity returns to 'C' - 'A'.

Figure 1 - Switch Circuit Diagram

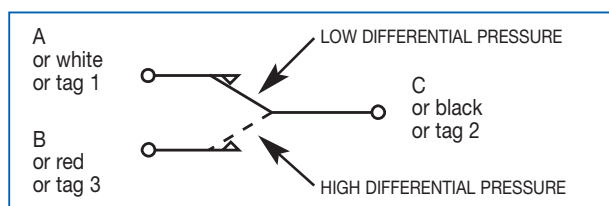

7 Filter element servicing

During servicing, the external surfaces of the filter assembly must be cleaned to remove any dust deposits.

Servicing must be conducted using suitable tools that do not present a hazard.

Servicing must not be carried out when a potentially explosive atmosphere is present.

CAUTION:

Filter elements should be replaced upon indication or at specified intervals, six months maximum. Failure to change the element will cause the filter to go on bypass.

Refer to Service Parts List (Section 10) for item numbers for applicable replacement element series. Remove and replace element as follows:

- 7.1 Turn off and depressurize the system. Open vent plug (10) at top of filter on the cover assembly (5) one and one-half turns.

WARNING:

FAILURE TO DEPRESSURISE THE FILTER BEFORE SERVICING ELEMENT COULD RESULT IN EXPLOSIVE LOSS OF FLUID, DAMAGE TO EQUIPMENT AND POSSIBLE PERSONAL INJURY.

- 7.2 Open one or both drain plugs (11) on bottom of filter head and drain housing. Reinstall and tighten drain plug(s).
- 7.3 Manually turn filter housing handle counter-clockwise to remove cover assembly. No tools should be needed or used to remove the cover assembly.

Note: The UR619/699C series assembly is equipped with an extraction mechanism within the cover assembly. Turn the cover handle counterclockwise until handle threads disengage then lift the cover slightly to pull the element free from its cage. Releasing the tension on the cover will allow "retraction spring clips" (located in the cover assembly) to return to their free position. Cover can now be removed, making the element accessible.

- 7.4 Remove filter element (8) and carefully inspect the surface for visible contamination. Normally no dirt should show, but visible dirt or particles can be an early warning of system component breakdown and can indicate potential failure. Discard both the filter element and its O-ring (6a). The filter element is NOT CLEANABLE. Any attempt to clean the filter element can cause degradation of the filter medium and allow contaminated fluid to pass through the filter element.

WARNING:

DO NOT ATTEMPT TO CLEAN OR RE-USE THE ELEMENT. ONLY USE GENUINE PALL REPLACEMENT FILTER ELEMENTS. USE OF SUBSTITUTE ELEMENTS MAY INVALIDATE PRODUCT WARRANTY.

- 7.5 Inspect filter cover assembly (5) for possible damage or malfunction. Replace any damaged parts. Remove any accumulated dirt. DO NOT run the system without a filter element installed. Check that the O-ring on the cover (6b) assembly is not damaged. Use replacement filter element part number called for on assembly nameplate.

WARNING:

FAILURE TO REPLACE DAMAGED PARTS IN FILTER CAN CAUSE COMPONENTS IN THE SYSTEM TO FAIL OR DEGRADE IN THEIR PERFORMANCE.

- 7.6 Lubricate the element O-rings with clean system fluid and install element over the center post (3) and into its cage (shell) assembly (4). Reset the visual indicator, if fitted, before refitting cover. Lightly lubricate cover O-ring with clean system fluid and refit cover assembly ensuring it engages with the center post threads. **HAND TIGHTEN** cover handle until cover assembly and body assembly are bottomed together. O-ring sealing is not improved by over tightening. **DO NOT USE PIPE, WRENCH, HAMMER, OR ANY OTHER TOOL TO TIGHTEN HANDLE!**
- 7.7 Open vent plug (10) on housing and pressurize system. This allows clean pressurized fluid to fill the housing and bleed off air.
- 7.8 Close vent plug on appearance of clear fluid. Check for leaks.
- 7.9 After element change **ENSURE VISUAL DIFFERENTIAL PRESSURE DEVICE IS RESET BY PUSHING IN THE RED BUTTON**; electrical switches reset automatically. When system reaches normal operating temperature, check that the electrical switch has not actuated and/or the visual warning button has remained depressed. If visual indicator rises due to a cold start condition, reset again as per section 6

8 Warranty, Limitation of Liability and Remedies

THERE IS NO WARRANTY OF MERCHANTABILITY OR FITNESS FOR ANY PARTICULAR PURPOSE WITH RESPECT TO ANY OF THE PRODUCTS, NOR IS THERE ANY OTHER WARRANTY EXPRESS OR IMPLIED, EXCEPT AS PROVIDED FOR HEREIN.

For a period of twelve months from the date of delivery from Seller or three thousand hours of use, whichever occurs first (the "Warranty Period", Seller warrants that products manufactured by Seller when properly installed and maintained, and operated at ratings, specifications and design conditions, will be free from defects in material and workmanship. By way of explanation and not limitation, the Seller does not warrant the service life of the filter element as this is beyond the Seller's control and depends upon the condition of the system into which the filter is installed.

Seller's liability under any warranty is limited solely (in Seller's discretion) to replacing (FOB original ship point), repairing or issuing credit for products that become defective during the Warranty Period. Purchaser shall notify Seller promptly in writing of any claims and provide Seller with an opportunity to inspect and test the product claimed to be defective. Buyer shall provide Seller with a copy of the original invoice for the product, and prepay all freight charges to return any products to Seller's factory, or other facility designated by Seller. All claims must be accompanied by full particulars, including system operating conditions, if applicable.

Seller shall not be liable for any product altered outside of the Seller's factory except by Seller or Seller's authorized distributor, and then, as to the latter, only for products which have been assembled by the distributor in accordance with Seller's written instructions. Nor shall Seller be liable for a product subjected to misuse, abuse, improper installation, application, operation, maintenance or repair, alteration, accident or negligence in use, storage transportation or handling. In no event will Seller be liable for any damages, incidental, consequential or otherwise, whether arising out of or in connection with the manufacture, packaging, delivery, storage, use, misuse, or non use of any of its products or any other cause whatsoever.

9 Parts List

List	Description	Catalog Number	Quantity
1	Filter Head		1
2	Tube		1
3	Centre post		1
4	Shell assembly (cage)		1
5	Cover assembly		1
6a, 6b	O-rings	UR619SKZ / UR699SKZ Seal Kit (fluorocarbon)	1
7	Indicator / Blanking plug	See product literature	2
8	Filter element	UE619**++Z See product literature	1
9	Indicator plug port		1
10	Vent plug		1
11	Bleed/drain plugs		2
12	Fill plug		1
13	Mounting bracket kit		1

UR619/699

RETURN LINE FILTERS

UR619/699 Series

service instructions

Figure 2

UR619 Series

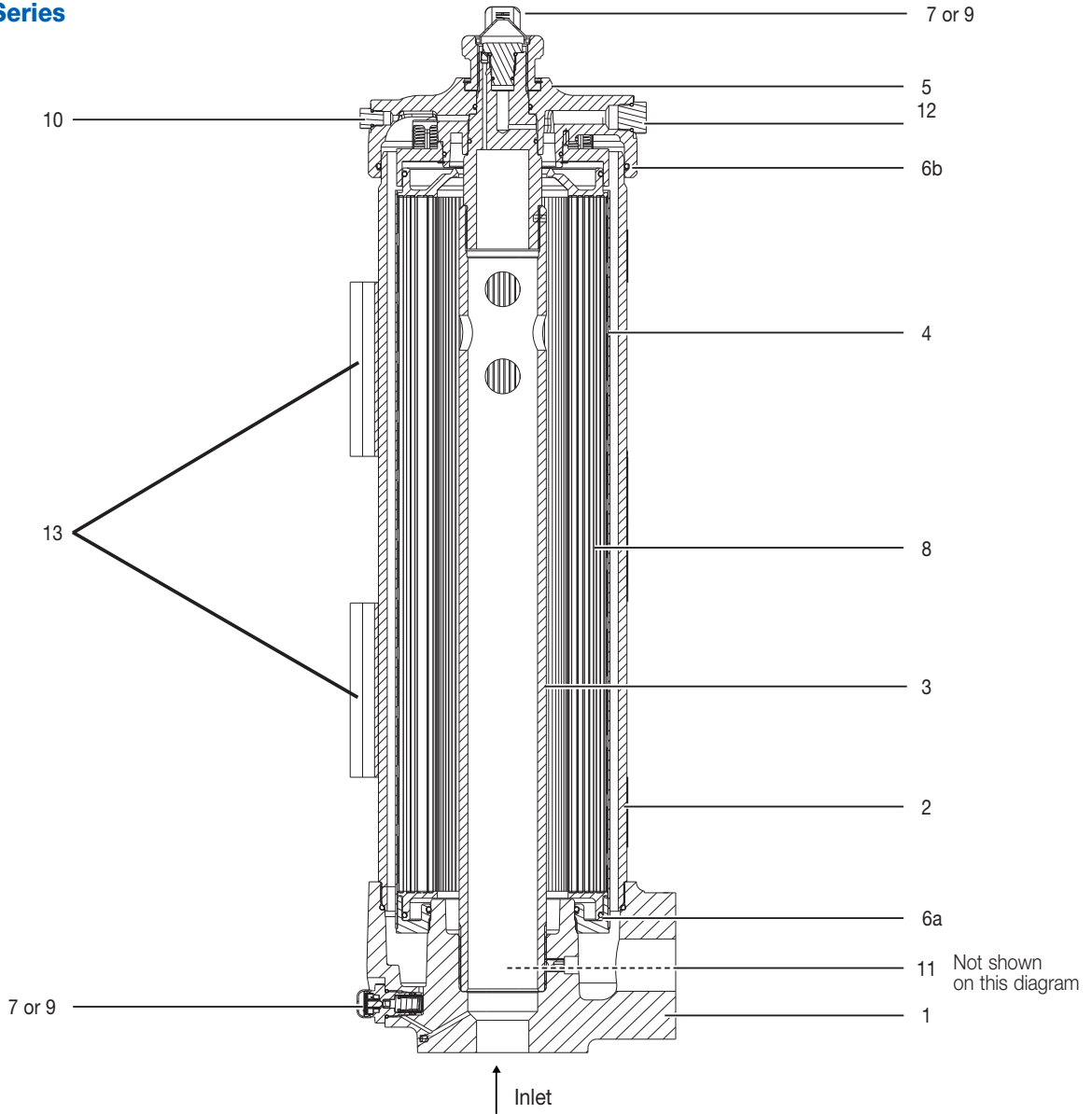

UR699 Series

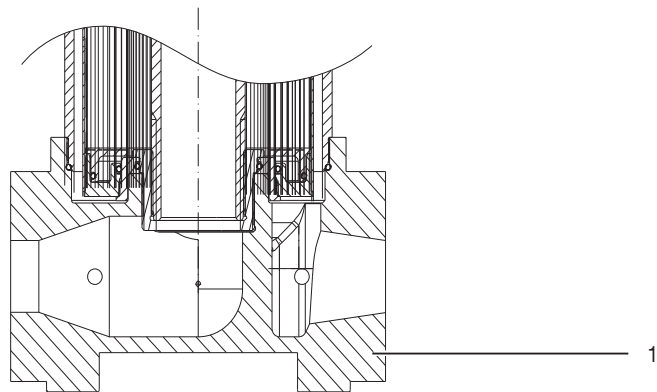

UR619/699

RETURN LINE FILTERS

UR619/699 Series

service instructions

Figure 3

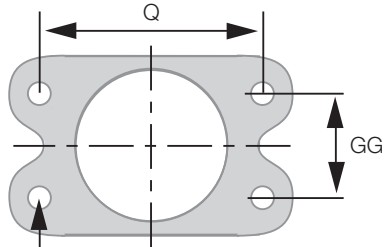

- Z
- 4 HOLES FULL THREAD DEPTH AA
- 4 Gewindebohrungen mit Gewindetiefe AA
- 4 huller med gevind, dybde AA
- 4 taladros pasantes roscados. Profundidad AA
- 4 täyskierteistä reikää, syvyys AA
- 4 trous taraudés de profondeur AA
- 4 fori completamente filettati profondità AA
- 4 tappaten (met draad over volle diepte)
- 4st fästhål. Gänga "Z". Min gängdjup "AA"

Flange Connection Details

Flange Code	Nominal Tube Size	GG	Q	Z Thread	AA
D24	1½"	1.406"	2.750"	½" - 13 UNC	1"
F24	1½"	35.7 mm	69.8 mm	M12 x 1.75	25 mm
D32	2"	1.688"	3.062"	½" - 13 UNC	1"
F32	2"	42.9 mm	77.8 mm	M12 x 1.75	25 mm
D40	2½"	2.000"	3.500"	½" - 13 UNC	1"
F40	2½"	50.8 mm	88.9 mm	M12 x 1.75	25 mm
D48	3"	2.438"	4.188"	⅝" - 11 UNC	1"
F48	3"	61.9 mm	106.4 mm	M16 x 2.00	25 mm

UR619/699

RETURN LINE FILTERS

UR619/699 Series

service instructions



Pall Corporation

Pall Industrial Manufacturing

New York - USA

+1 888 333 7255 toll free
+1 516 484 3600 telephone
+1 516 484 6247 fax

Portsmouth - UK

+44 (0)23 9230 3303 telephone
+44 (0)23 9230 2507 fax

Visit us on the web at www.pall.com

Pall Corporation has offices and plants throughout the world in locations including: Argentina, Australia, Austria, Belgium, Brazil, Canada, China, France, Germany, India, Indonesia, Ireland, Italy, Japan, Korea, Malaysia, Mexico, the Netherlands, New Zealand, Norway, Poland, Puerto Rico, Russia, Singapore, South Africa, Spain, Sweden, Switzerland, Taiwan, Thailand, United Arab Emirates, United Kingdom, United States, and Venezuela. Distributors are located in all major industrial areas of the world.

Because of developments in technology these data or procedures may be subject to change. Consequently we advise users to review their continuing validity annually. Part numbers quoted above are protected by the Copyright of Pall Europe Limited.

PALL, Pall and Ultipleat are trademarks of Pall Corporation.
Filtration. Separation. Solution is a service mark of Pall Corporation.

® indicates a trademark registered in the USA.

© Copyright 2008, Pall Corporation.

Filtration. Separation. Solution.SM