

# NAB Nanosep® Device Quick-Start Guide

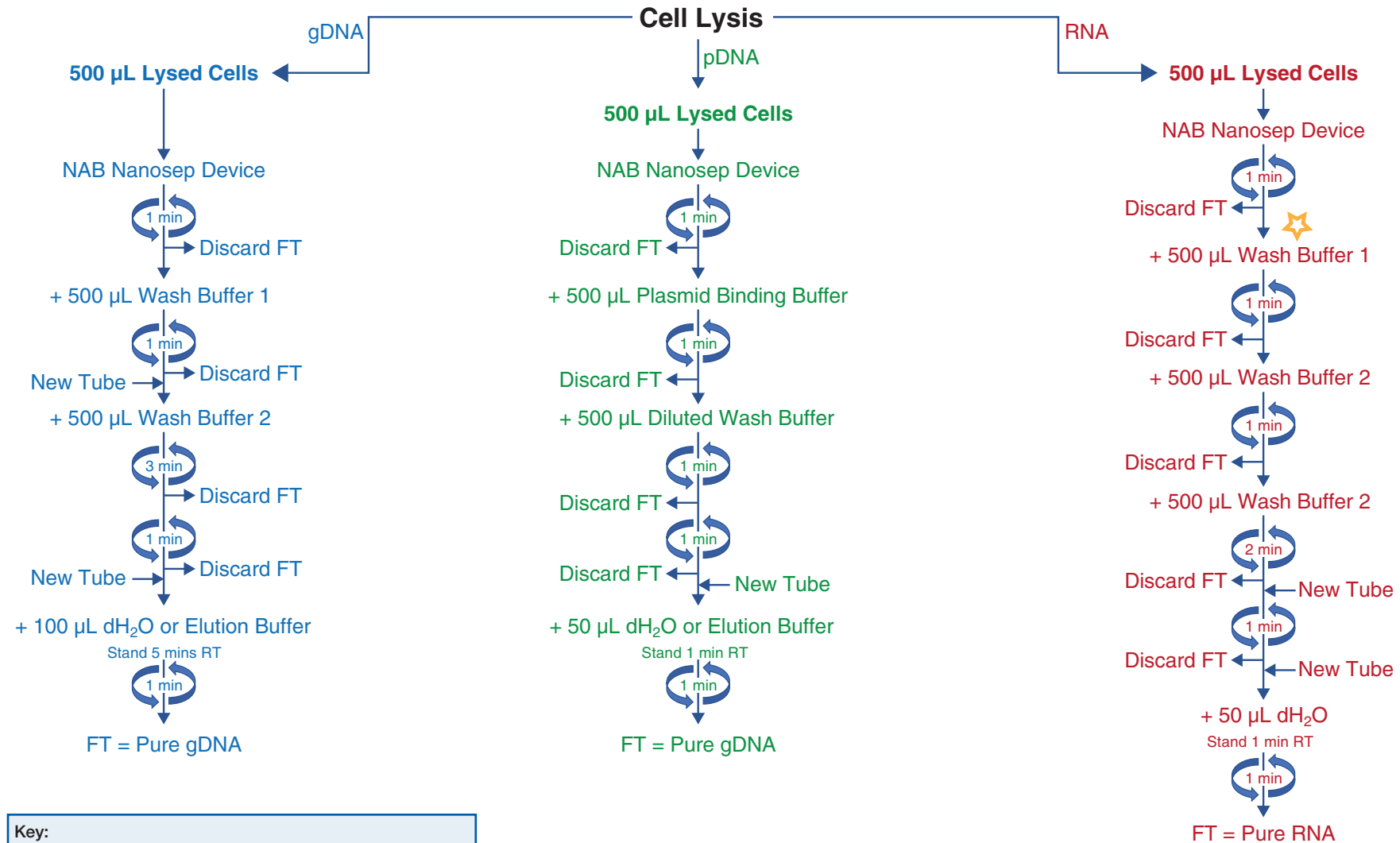

**Key:**

FT – Flow Through	pDNA – Plasmid DNA
☺ - Centrifuge 10-14,000 x g	dH <sub>2</sub> O – RNase-free water
gDNA – Genomic DNA	RT – Room Temperature

☺ For optional DNA/RNA digestion processes, as well as full instructions and translations, search 'NAB Nanosep' on the Pall website.