



EMR Series Filter Housings

Economical ASME Code Multi-Cartridge Filter Housing for Industrial Applications

- Accepts from 12 to 55 20" (50.8 cm), 30" (76.2 cm) or 40" (102 cm) DOE Style Cartridges
- Housings Can Be Easily Modified to Accept Single Open End Style Cartridges
- Rugged and Economical Design
- Carbon Steel Materials of Construction
- 150 PSIG (10.3 BAR) Maximum Operating Pressure Permits Use in Many Applications
- ASME Code Section VIII, Division I "UM", and "U" Stamp

Housing Specifications

Maximum Operating Pressure:

150 psig (10.3 bar) @ 500°F (260°C)

NOTE: Maximum operating pressure ratings are vessel ratings only. Safe operating temperature and pressure will depend on filter cartridge and gasket/O-ring used. For inquiries on compatibility, contact the factory or your Pall distributor.

Construction:

Standard: ASME Code UM & U Stamp

Connections:

Inlet/Outlet: 3" - 8" ANSI RF Flange

Body Drain: 1½" NPT

Vent: ¾" NPT

Drain: ¼" NPT

Shell Gaskets:

Buna N (standard), Viton¹ A, Silicone Elastomer, Neoprene, Ethylene Propylene

Cartridge Sealing Options:

316 stainless steel tube guides and compression spring assemblies are standard for use with DOE style cartridges. ACCU-SEAL™ and UNI-SEAL™ sealing systems are optional for use with DOE style cartridges. A 222 O-ring seal is optional for SOE M3/Code 3 style cartridges.

Dimensional Data (nominal)

Model	Cartridge Length (inches)	# of Cartridges	# of 10" Equiv.	Dimensions (inches)						Flow ² Rate (gpm)
				A	B	C	D	E	F	
24EMR2-3FD-C150UM-IP	20 (50.8 cm)	12	24	60 (152.4 cm)	8 ¾ (21.9 cm)	12 ¾ (32.4 cm)	16 (40.6 cm)	11 (28 cm)	3 (7.6 cm)	120 (454 lpm)
36EMR3-3FD-C150UM-IP	30 (76.2 cm)	12	36	70 (177.8 cm)	8 ¾ (21.9 cm)	12 ¾ (32.4 cm)	21 (53.3 cm)	11 (28 cm)	3 (7.6 cm)	1848 (6995 lpm)
48EMR4-3FD-C150UM-IP	40 (102 cm)	12	48	80 (203.2 cm)	8 ¾ (21.9 cm)	12 ¾ (32.4 cm)	21 (53.3 cm)	11 (28 cm)	3 (7.6 cm)	240 (909 lpm)
36EMR2-3FD-C150UM-IP	20 (50.8 cm)	18	36	60 (152.4 cm)	9 ¼ (23.5 cm)	14 (35.6 cm)	16 (40.6 cm)	11 (28 cm)	3 (7.6 cm)	180 (681 lpm)
54EMR3-3FD-C150UM-IP	30 (76.2 cm)	18	54	70 (177.8 cm)	9 ¼ (23.5 cm)	14 (35.6 cm)	21 (53.3 cm)	11 (28 cm)	3 (7.6 cm)	270 (1022 lpm)
72EMR4-3FD-C150UM-IP	40 (102 cm)	18	72	80 (203.2 cm)	9 ¼ (23.5 cm)	14 (35.6 cm)	21 (53.3 cm)	11 (28 cm)	3 (7.6 cm)	360 (1363 lpm)
44EMR2-4FD-C150UM-IP	20 (50.8 cm)	22	44	61 (155 cm)	10 ¾ (26.4 cm)	16 (40.6 cm)	16 (40.6 cm)	12 (30.5 cm)	4 (10.2 cm)	220 (833 lpm)
66EMR3-4FD-C150UM-IP	30 (76.2 cm)	22	66	71 (180.3 cm)	10 ¾ (26.4 cm)	16 (40.6 cm)	21 (53.3 cm)	12 (30.5 cm)	4 (10.2 cm)	330 (1249 lpm)
88EMR4-4FD-C150UM-IP	40 (102 cm)	22	88	82 (208.3 cm)	10 ¾ (26.3 cm)	16 (40.6 cm)	21 (53.3 cm)	12 (30.5 cm)	4 (10.2 cm)	440 (1666 lpm)
72EMR2-6FD-C150UM-IP	20 (50.8 cm)	36	72	69 (175.3 cm)	12 ½ (31.8 cm)	20 (50.8 cm)	18 (45.7 cm)	16 (40.6 cm)	6 (15.2 cm)	360 (1363 lpm)
108EMR3-6FD-C150UM-IP	30 (76.2 cm)	36	108	81 (206 cm)	12 ½ (31.8 cm)	20 (50.8 cm)	24 (61 cm)	16 (40.6 cm)	6 (15.2 cm)	540 (2044 lpm)
144EMR4-6FD-C150UM-IP	40 (102 cm)	36	144	90 (228.6 cm)	12 ½ (31.8 cm)	20 (50.8 cm)	24 (61 cm)	16 (40.6 cm)	6 (15.2 cm)	720 (2726 lpm)
110EMR2-6FD-C150UM-IP	20 (50.8 cm)	55	110	66 (167.6 cm)	14 ¾ (37.1 cm)	24 (61 cm)	20 (50.8 cm)	16 (40.6 cm)	6 (15.2 cm)	550 (2082 lpm)
165EMR3-6FD-C150UM-IP	30 (76.2 cm)	55	165	80 (203.2 cm)	14 ¾ (37.1 cm)	24 (61 cm)	24 (61 cm)	16 (40.6 cm)	6 (15.2 cm)	825 (3123 lpm)
220EMR4-6FD-C150UM-IP	40 (102 cm)	55	220	91 (231.1 cm)	14 ¾ (37.1 cm)	24 (61 cm)	24 (61 cm)	16 (40.6 cm)	6 (15.2 cm)	1100 (4164 lpm)

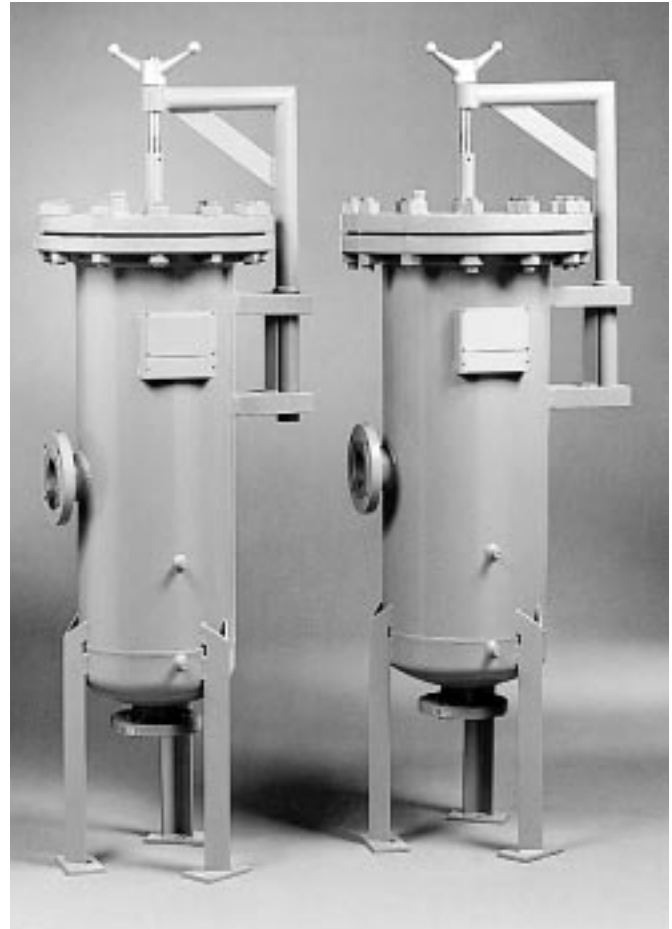

Customization:

Housings can be engineered to meet the specific needs of a process and installation. Contact your local Pall distributor or Technical Services for assistance.

¹ - Registered trademark of DuPont Dow.

² - For viscosity and specific gravity similar to water.

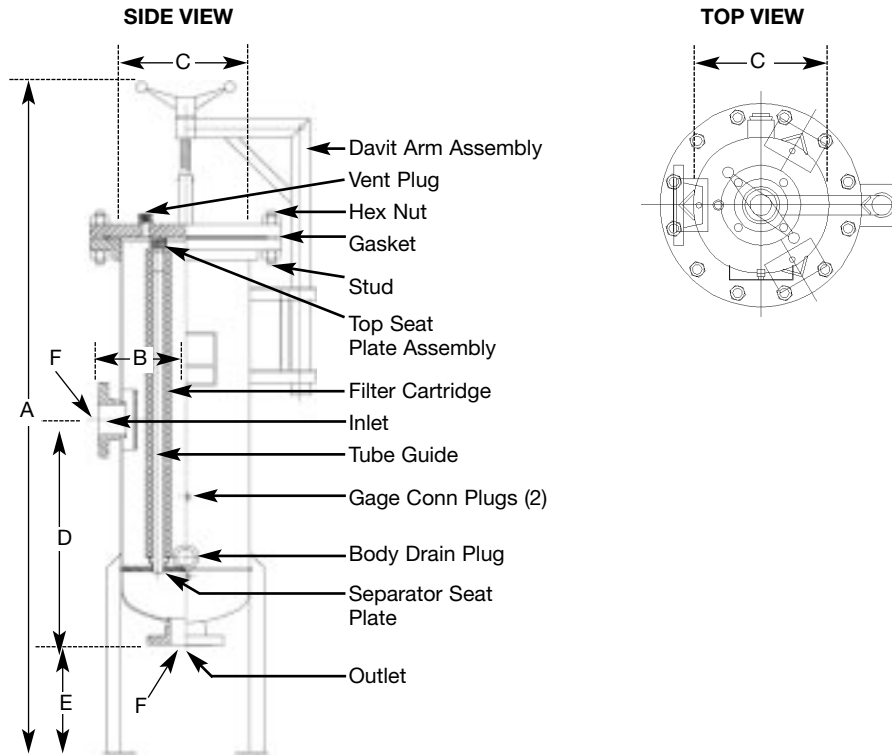

Part Numbers/Ordering Information

■ EMR ● - ◆ FD - C150 ▶ - Ⓢ (e.g., 36EMR3-3FD-150UM-IP)

Code	No. of 10" Equivalents
24	24
36	36
44	44
48	48
54	54
66	66
72	72
88	88
108	108
110	110
165	165
220	220

Code	Cartridge Lengths
2	20"
3	30"
4	40"

Code	Inlet/Outlet Connection Sizes
◆ 3	3"
◆ 4	4"
◆ 6	6"
◆ 8	8"

Code	ASME Stamp Designation
▶ UM	UM Stamp
▶ U	U Stamp

Code	Internal Parts ³
Ⓢ Blank	No Internal Parts
Ⓢ IP	Internal Parts

³ - Standard vessels include internal parts of top seat plates and tube guides. Basic vessels without internal parts may be ordered as non-stock items.



2200 Northern Boulevard.
East Hills, New York 11548-1289

1.800.FILTERS toll free
516.484.5400 phone
516.484.3216 fax
information@pall.com e-mail

Visit us on the Web at www.pall.com

Pall Corporation has offices and plants throughout the world in locations including: Argentina, Australia, Austria, Belgium, Brazil, Canada, China, France, Germany, Hong Kong, India, Indonesia, Ireland, Italy, Japan, Korea, Malaysia, Mexico, the Netherlands, New Zealand, Norway, Poland, Puerto Rico, Russia, Singapore, South Africa, Spain, Sweden, Switzerland, Taiwan, Thailand, United Kingdom, United States, and Venezuela. Distributors are located in all major industrial areas of the world.

Filtration. Separation. Solution.SM

© Copyright 2004, Pall Corporation. Pall, PALL, Accu-Seal and Uni-Seal are trademarks of Pall Corporation.
® Indicates a Pall trademark registered in the USA. Filtration. Separation. Solution.SM is a service mark of Pall Corporation.