

## Marksman™ Series Filter Housings

### For Use With Marksman Series Filter Elements

- One-, four-, seven-, and nine-around models
- Other sizes are available upon request
- ASME U and UM stamps are available for all sizes
- Housings are constructed of 316L stainless steel for corrosion resistance
- Baskets included
- Swing bolt closure design ensures secure sealing and easy change-out
- Adjustable length legs with side inlet and bottom outlet on single element housings
- Side in/side out flow design on multi-around housing allows for easy piping layout

### Housing Specifications

#### Maximum operating pressure

Stainless steel: 10.3 bar @ 93°C (150 psig @ 200°F)

NOTE: Maximum operating pressure and temperature ratings in liquids are vessel ratings only (including vessel shell O-rings). Safe operating temperature and pressure will depend on the filter cartridge and filter gasket used. For inquiries on compatibility, contact the factory or your Pall distributor.

#### Construction

Non-code: Available for all sizes  
Code: ASME U or UM stamp available for all sizes

#### Connections

Inlet/Outlet: 2" – 8" flange  
Option: 2" NPT for 1-around, Size #1 model  
Drain<sup>1</sup>: 1 ½" NPT  
Vent: 1" NPT (¼" NPT on single housing)  
Gauge<sup>1</sup>: ¼" NPT (upstream/downstream)

**Shell O-rings** Nitrile (standard), silicone elastomer, neoprene, ethylene propylene, fluorocarbon elastomer

<sup>1</sup> Applies to multi-around housing only.



### Filter Element Specifications

Marksman housings are designed to accept the entire family of Marksman filter elements, including Marksman DFN filters, Marksman NXA filters, Marksman PFT filters, and Marksman XLD filters. Size 1, Size 2, and 101.6 cm (40 in) cartridges are available with Pall's proprietary sliding flange. Refer to individual data sheets for detailed information on Marksman series filter elements.

## Dimensional Data (nominal)<sup>2</sup>

Model	Number of cartridges	Size (nominal)	Code	Liquid flow rate <sup>3</sup> lpm (gpm)	Dimensions cm (in)							Inlet/outlet	Dry weight kg (lbs) <sup>4</sup>
					A	B	C	D (height)	E	F	G		
1MAR1	1	1	N	227 (60)	21.6 (8.5)	54.6 (21.5)	31.8 (12.5)	109 (43)	25.4 (10)	N/A	30.2 (11.875)	5.1 (2)	35 (77)
1MAR2	1	2	N	454 (120)	21.6 (8.5)	89 (35)	31.8 (12.5)	145 (57)	25.4 (10)	N/A	30.2 (11.875)	7.6 (3)	50 (110)
1MAR1	1	1	Y	227 (60)	21.6 (8.5)	54.6 (21.5)	28 (11)	109 (43)	25.4 (10)	N/A	30.2 (11.875)	5.1 (2)	55.8 (123)
1MAR2	1	2	Y	454 (120)	21.6 (8.5)	89 (35)	28 (11)	145 (57)	25.4 (10)	N/A	30.2 (11.875)	7.6 (3)	62.6 (138)
4MAR2	4	2	Y	1817 (480)	50.8 (20)	63.5 (25)	50.8 (20)	200 (79)	40.6 (16)	81.3 (32)	51.4 (20.25)	15.2 (6)	258.5 (570)
7MAR2	7	2	Y	3179 (840)	61 (24)	63.5 (25)	50.8 (20)	200 (79)	45.7 (18)	91.4 (36)	61.6 (24.25)	15.2 (6)	335.6 (740)
9MAR2	9	2	Y	4088 (1080)	76.2 (30)	53.3 (21)	61 (24)	213 (84)	53.3 (21)	107 (42)	78.4 (30.875)	15.2 (6)	553.3 (1220)

<sup>2</sup> 102 cm (40 in) housing specifications are available upon request.

<sup>4</sup> Weights listed are for vessels with flange connections.

<sup>3</sup> Flow rates listed are for depth cartridges. Consult Pall for more specific information.

### Side View (1-Around Housing)

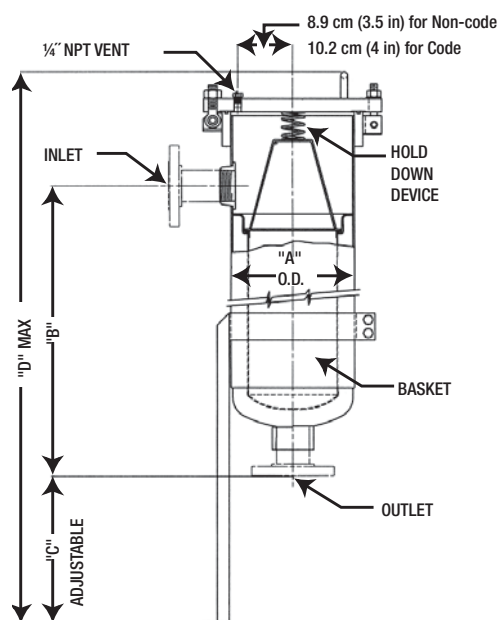

### Side View (Multi-Around Housing)

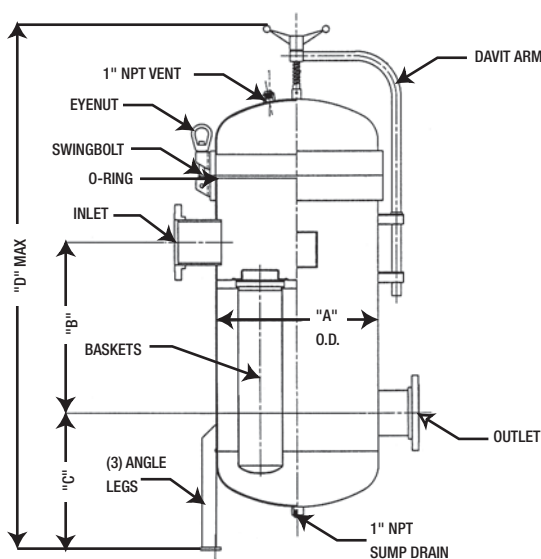

### Top View (1-Around Housing)

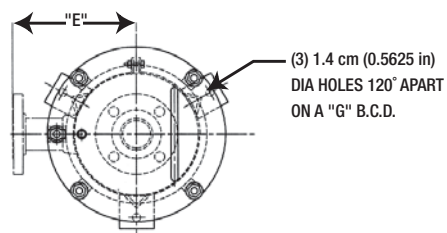

### Top View (Multi-Around Housing)

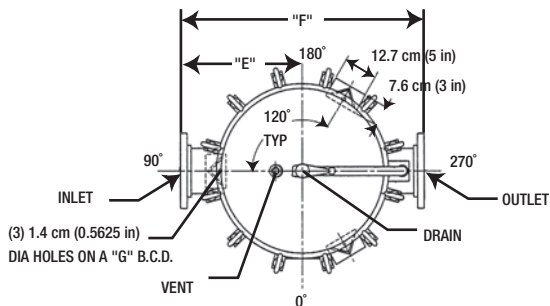

## Ordering Information

Pall Part Number = 1 MAR 2 - 316L - 3 4 - 5 150 6

**Table 1**

Code	No. of Marksman elements
1	1
4	4
7	7
9	9

**Table 2**

Code	Cartridge lengths nominal
1	Size 1 bag
2	Size 2 bag
4	101.6 cm (40 in)

**Table 3**

Code	Inlet/outlet connection sizes
2	2"
3	3"
6	6"
8	8"

**Table 4**

Code	Connection styles
Blank	NPT
F	Flange

**Table 5**

Code	Code construction
C	Code construction
Blank	Non-code construction

**Table 6**

Code	ASME stamp designation
UM	UM stamp
U	U stamp



**Pall Corporation**

25 Harbor Park Drive  
Port Washington, NY 11050  
+1 516 484 3600 telephone  
+1 888 873 7255 toll free US

Portsmouth - UK  
+44 (0)23 9230 3303 telephone  
+44 (0)23 9230 2507 fax  
processuk@pall.com

### Visit us on the Web at [www.pall.com](http://www.pall.com)

Pall Corporation has offices and plants throughout the world. For Pall representatives in your area, please go to [www.pall.com/contact](http://www.pall.com/contact).

Because of technological developments related to the products, systems, and/or services described herein, the data and procedures are subject to change without notice. Please consult your Pall representative or visit [www.pall.com](http://www.pall.com) to verify that this information remains valid.

© Copyright 2004, 2012, Pall Corporation. Pall,  and Marksman are trademarks of Pall Corporation. ® indicates a trademark registered in the USA. **Filtration. Separation. Solution.<sup>SM</sup>** is a service mark of Pall Corporation.