



Pall Corporation

[www.pall.com](http://www.pall.com)

# Contamination Control

for the Oil and Gas Industry



*Filtration. Separation. Solution.<sup>SM</sup>*



*Pall specializes in fluid  
management, leveraging  
our unmatched capabilities  
to make your operation  
more successful*

# Introduction to Pall Corporation

## Pall - Your Integrated partner in the Oil and Gas industry

Pall Corporation is a global company solving complex contamination, separation and purification problems.

Pall serves the oil and gas, refinery, petrochemical, chemical, and power generation markets around the world. With a broad line of products and services, Pall can help you improve fluid quality and increase profitability by optimizing the performance of processing equipment.



## The oil and gas industry trusts Pall as a solution provider

For more than thirty years, Pall has been a major equipment supplier and solution provider to oil and gas companies at both onshore and offshore plants.

Regardless of your specialization, Pall has filtration and separation solutions to meet your increasing production and processing needs. Our products are designed to meet your requirements for separation efficiency, reliability, economy, and size.

Pall can solve your purification challenges in any size of application, from small flows and simple installations to large flows and complex systems, from the supply of filter elements to fully-integrated turnkey systems.



## Benefit from Pall's expertise and customized services

Pall is much more than a filter company. Pall specializes in fluid management, leveraging our unmatched capabilities to make your operation more successful. Our expertise has enabled us to build a large library of proprietary core materials, which we can modify to separate, remove, or selectively capture the most elusive contaminants.

## Total Fluid Management<sup>SM</sup>(TFM)

Pall has the ability to design, manufacture, and install economical, integrated systems as well as service them. Our systems can cost effectively treat all of the incoming process fluids, systems fluids, and waste streams in your plant. By meeting critical needs, we build lasting customer relationships that grow stronger year after year. We call this Total Fluid Management, a comprehensive approach, that leverages our strengths and provides you with real value.



# Contamination Control

## Why is it so important to take care of fluid cleanliness?

Solid, liquid, and salt-like contaminants present in gas and liquid well-injection fluids, process fluids (crude oil, gas, NGL, amine, glycol, water...), systems fluids (hydraulic and lubrication oil) can lead to operating and maintenance issues at wells, on treating units, and machinery and equipment.

Increase in operating and maintenance costs, decrease in production throughputs, production shutdowns or equipment failure can significantly affect productivity of oil and gas production plants, gas treating plants, LNG plants, and transmission stations.

Such issues can be solved by the use of effective, reliable, correctly applied filtration and separation technologies.



New low NOx burner tip



Damaged NOx burner tip due to contaminants

*Let Pall help you optimize the performance of your processing units and equipment by improving fluids contamination control!*

Experience has demonstrated that improving fluids cleanliness can enable oil and gas producers:

- ▶ To eliminate operating issues due to:
  - foaming in contactor towers
  - premature fouling of adsorbents and catalysts
  - off-spec products
- ▶ To decrease operating costs due to:
  - energy consumption linked to clogging of adsorbents and catalysts, heat exchangers, reboilers, cold box, and columns
  - premature replacement of adsorbents and catalysts solvent make-ups or use of chemicals such as antifoams
- ▶ To eliminate untimely or unplanned maintenance operations due to:
  - cleaning of heat exchangers, reboilers, cold box, columns, compressors
  - replacement of turbine/compressor bearings and other internals
  - corrosion of equipment and pipelines
- ▶ To eliminate unforeseen shutdowns due to clogging or failure of compressors or turbines
- ▶ To comply with Health, Safety, and Environment specifications



# Pall Filtration & Separation Technologies

The potential application of Pall technologies is vast. The following schematic diagrams represent three typical oil and gas Industry processes to provide an indication of how and where Pall filtration and separation solutions can be applied.

## Pall Filtration and Separation Applications at Oil and Gas Production Plants

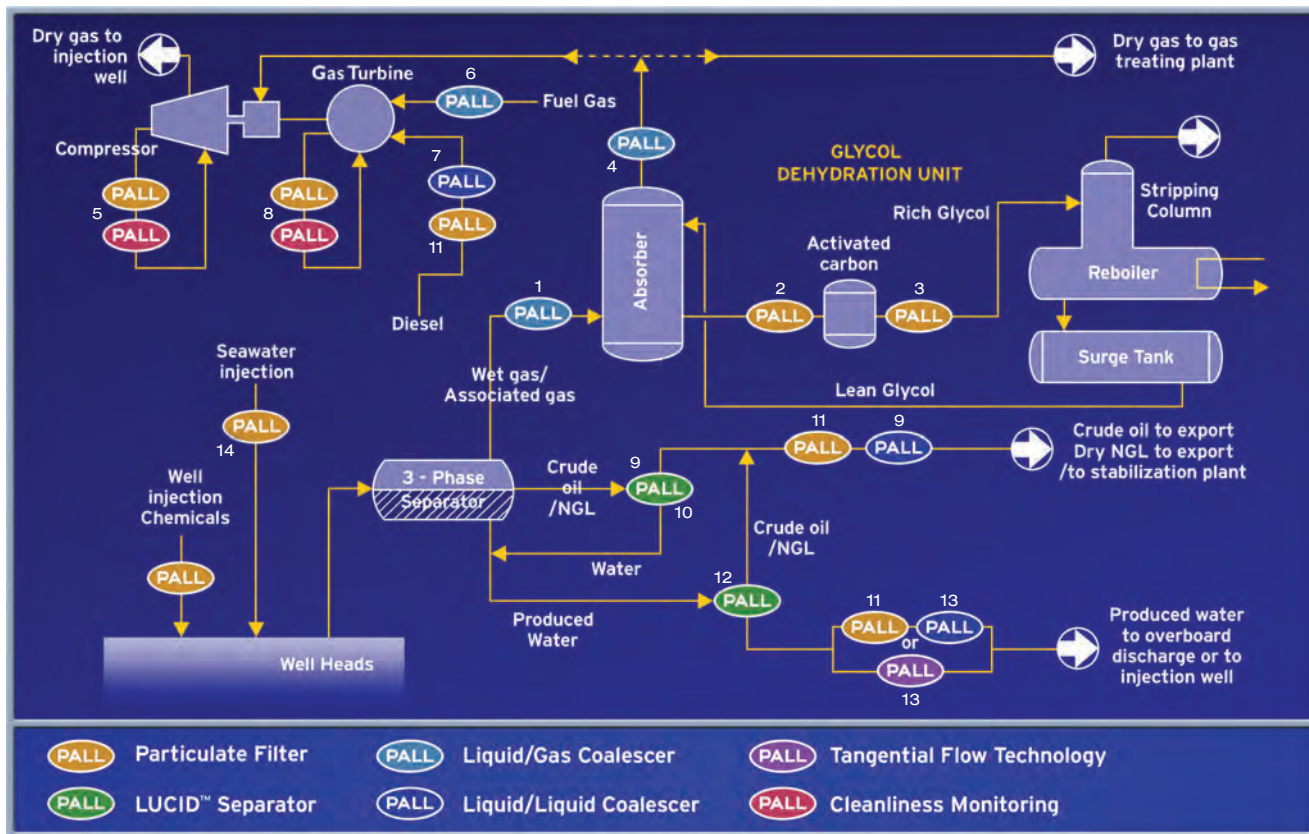

Production and Treating processes vary and layout and equipment may differ. Consequently not all purification steps listed may apply

### Filtration Recommendations

Each Pall solution within the flow diagram above is labelled and described in the chart below.

#	Application	Challenge	Solution
1	Glycol contactor protection	Prevent hydrocarbon or amine aerosols, and solids from contaminating the glycol system, which could result in foaming, solvent losses, and off-specification gas. Recover valuable NGL or amine for re-use.	Install liquid/gas coalescers to remove finely dispersed liquid droplets and solids from the gas before it enters the glycol system.
2	Upstream activated carbon bed in amine or glycol	Remove solid contaminants from solvent to avoid foaming in the contactor and protect the activated carbon bed from plugging.	Install high efficiency rated particle filters upstream of the activated carbon bed.
3	Downstream of activated carbon bed in amine or glycol	Remove any activated carbon fines released from the activated carbon bed to avoid solvent contamination.	Install high efficiency rated particle filters downstream of the activated carbon bed.
4	Compressor protection	Improve reliability of the compressor by preventing fouling from liquid aerosols and solids. Recover valuable NGL or glycol for re-use.	Install liquid/gas coalescers to remove finely dispersed liquid droplets and solids from the gas.
5	Compressor protection	Prevent solid particles from contaminating the lubrication and hydraulic oil systems, to avoid abrasion of bearings, and to protect servo-valves. Monitor oil cleanliness for predictive maintenance.	Install high efficiency rated particle filters on oil systems, and use diagnostic devices to control the oil cleanliness level.
6	Turbine protection	Eliminate liquid aerosols and solids from fuel gas, which could result in operation problems of the turbine and fouling of burner tips.	Install liquid/gas coalescers to remove finely dispersed liquid droplets and solids from the fuel gas.
7	Turbine protection	Eliminate free water and solids from diesel, which could result in corrosion and fouling of burner tips.	Install liquid/liquid coalescers to remove free water from diesel.

## Pall Filtration and Separation Applications at Gas Processing Plants

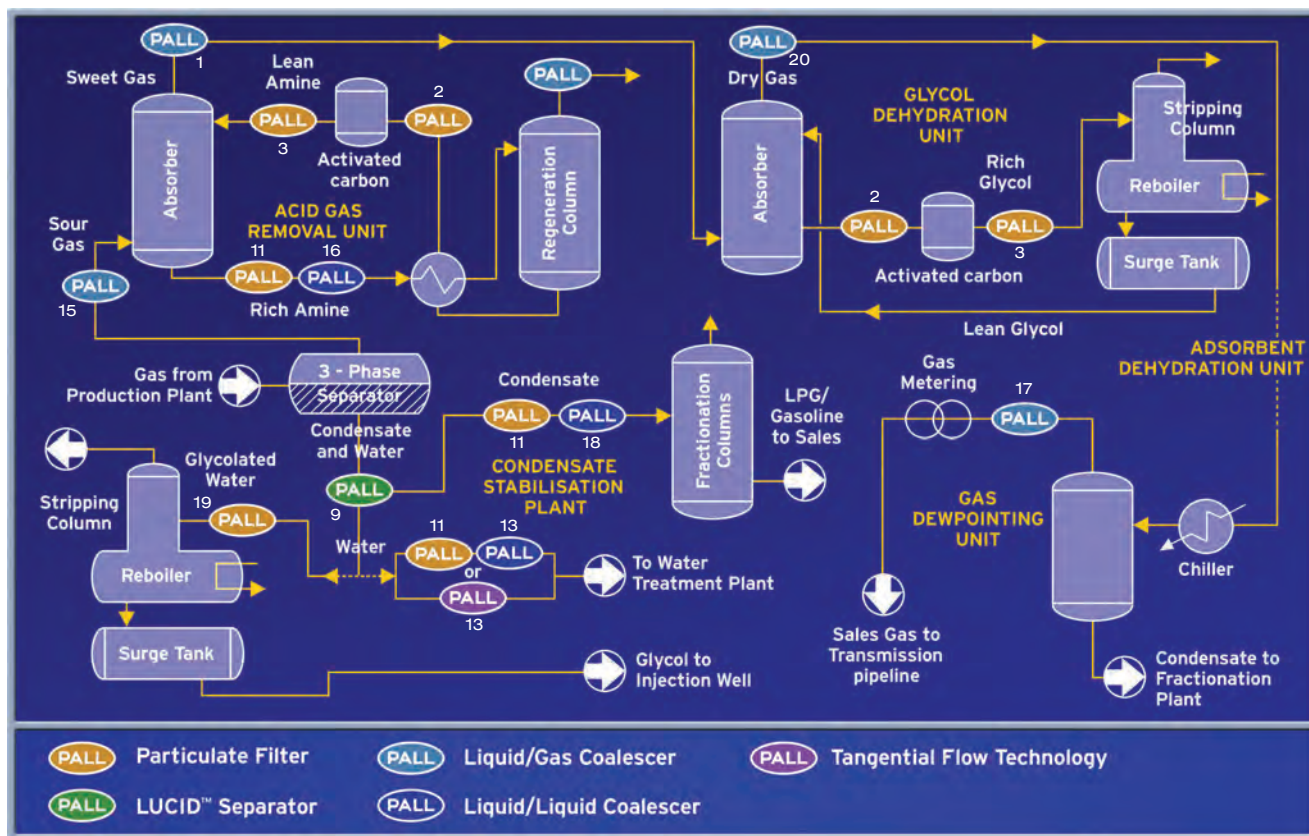

Production and Treating processes vary and layout and equipment may differ. Consequently not all purification steps listed may apply

### Filtration Recommendations

Each Pall solution within the flow diagram above is labelled and described in the chart below.

#	Application	Challenge	Solution
8	Turbine protection	Prevent solid particles from contaminating the lubrication and hydraulic oil systems, to avoid abrasion of bearings, and to protect servo-valves. Monitor oil cleanliness for predictive maintenance.	Install high efficiency rated particle filters on oil systems, and use diagnostic devices to control the oil cleanliness level.
9	Condensate dewatering	Provide hydrocarbon condensate with low water content to avoid corrosion problems in export pipeline.	Install liquid/liquid coalescers or a Lucid Separator to remove free water from hydrocarbon condensate.
10	Crude oil desalting	Provide crude oil with low water content to avoid corrosion problems in export pipeline.	Install a Lucid Separator to remove free water from crude oil.
11	Prefiltration prior to liquid/liquid coalescer	Ensure that the liquid/liquid coalescer has a long service life.	Install high efficiency rated particle filters upstream of the liquid/liquid coalescers.
12	Produced water and waste water treatment	Protect downstream equipment from upsets and maintenance issues due to large amounts of hydrocarbons and solids.	Install a Lucid Separator to remove free hydrocarbons and solids from produced or waste water.
13	Produced water and waste water treatment	Ensure that the water meets quality or environmental specifications prior to overboard discharge, re-injection, or further treatment.	Install liquid/liquid coalescers or tangential flow membrane modules to remove free hydrocarbons and solids from water.
14	Seawater injection	Prevent fine solids and microorganisms from fouling the injection wells.	Install high efficiency rated filters upstream of the injection pumps.
15	Amine contactor protection	Prevent hydrocarbon or glycol aerosols, and solids from contaminating the amine system, which could result in foaming, solvent losses, and off-specification gas. Recover valuable NGL.	Install liquid/gas coalescers to remove finely dispersed liquid droplets and solids from the gas before it enters the amine system.

## Pall Filtration and Separation Applications at LNG (Liquified Natural Gas) Plants

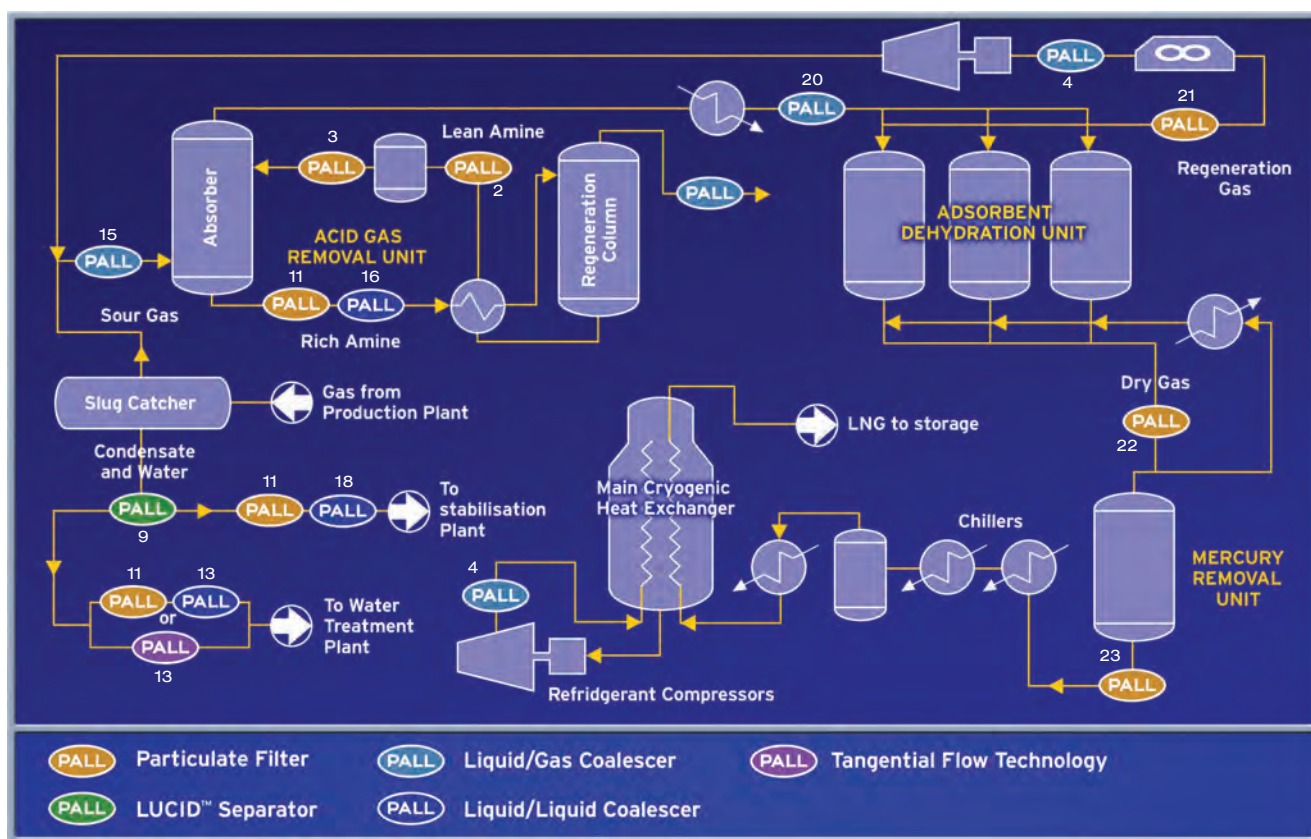

### Filtration Recommendations

Each Pall solution within the flow diagram above is labelled and described in the chart below.

#	Application	Challenge	Solution
16	Rich amine treatment	Improve the reliability of the amine regenerator by removing liquid hydrocarbons and solids.	Install liquid/liquid coalescers to remove free liquid hydrocarbons from the rich amine solvent prior the regenerator.
17	Gas metering protection	Ensure an accurate gas flowrate measurement by preventing liquids from depositing.	Install liquid/gas coalescers to remove finely dispersed liquid droplets prior the gas metering device.
18	Stabilization plant protection	Prevent free water and solids from entering the fractionation column, which could result in corrosion and salts and solid deposits.	Install liquid/liquid coalescers to remove free water from the hydrocarbon condensate.
19	Glycol regenerator protection	Prevent solid particles from entering the regenerator, which could result in fouling of the column and reboiler.	Install high efficiency rated particle filters upstream of the regenerator.
20	Molecular sieve drier protection	Increase cycle time between regeneration of the molecular sieve drier, and extend the bed life. Recover valuable glycol or NGL.	Install liquid/gas coalescers to remove finely dispersed liquid droplets before they foul the molecular sieve drier.
21	Regeneration gas filtration	Avoid molecular sieve fines being entrained with the regeneration gas, which could result in process contamination or fouling of downstream equipment.	Install gas particle filters to effectively remove any carryover molecular sieves fines.
22	Dry gas filtration	Prevent molecular sieve fines from fouling downstream equipment.	Install gas particle filters to effectively remove any carryover molecular sieves fines.
23	Cold Box protection	Ensure a consistent productivity of the cold box by preventing solid fines from fouling the heat exchanger.	Install gas particle filters to effectively remove any carryover solid fines.

For further information please request a copy of the Pall Filtration and Separation Technology interactive CD-ROM from your local Pall sales office or distributor.

# Pall Technology Services

## What is Total Fluid Management?

Total Fluid Management (TFM) is the integration of properly selected filtration and separation technologies and services into a production process to yield the highest efficiency at the lowest cost. Pall's TFM program covers a wide range of filtration products, advanced technologies, and services to improve system operation and increase productivity.

### Our global team of scientists and engineers support TFM

Pall offers a variety of services to help you maximize productivity within your plant. We deliver TFM to you with the support of our global teams of Scientific and Laboratory Services (SLS). Located in more than 30 countries, our scientists and engineers provide these services locally, with broad-based assistance from Pall's worldwide technical support network. Our experts work directly with you to determine how Pall products and technologies can benefit your process.

### Our customized system services include:

#### Cleanliness audit / Piloting

A cleanliness audit can uncover contamination problems and their detrimental effects. Our laboratory staff and field engineers have at your disposal lab-scale and analytical equipment and field pilot-scale units. By sampling at various locations throughout the process, we collect, quantify and identify solid and liquid contaminants to determine their origin and provide you with recommendations for corrective action. Our recommendations are designed to help you optimize your processes and increase the reliability of your equipment at the lowest possible cost.

#### Process audits / Consultancy

Pall offers troubleshooting, audit and consulting services to identify opportunities for process improvements that lead to increased productivity. Improvements are defined for instance as the reduction of operating costs or maintenance operations. An audit involves data collection and proposal review, followed by a technical report documenting the findings and suggestions for improvement.

#### Filtration equipment rental

When you need to rent filtration and purification equipment to conduct spot depollution of gas treating fluids or systems fluids, to conduct large-scale pilot testing, or to use while permanent equipment is being manufactured, contact Pall. Our rental services can provide equipment on the spot, so that you can handle upsets promptly



Consultancy



Piloting Rigs



Flushing Services



Filtration Equipment Hire



# Filtration and Separation Technologies for Process Fluids

## Pall filtration and separation technology

Pall designs and supplies a wide range of media, filters, and systems to remove contaminants from liquids and gases. These products, along with our service capabilities and technical expertise, enable us to fulfill diverse fluid purification requirements whether in oil and gas production, oil refining, gas processing, chemical production, or polymer processing.

### Particulate filters for Liquid and Gas

Pall gas and liquid particulate filters are used to remove the primary sources of contamination that cause system failures. Elements are designed in depth or pleated media configurations for maximum surface area and long service life.

*Pall Products: Ultipleat® High Flow, Ultipor®, Ultipleat® SRT, Profile® Coreless, Nexis®, Epocel® and Claris® filters*



### Liquid / Gas Coalescers

Pall liquid / gas coalescers remove entrained liquid aerosols from gas such as condensed hydrocarbons or pipeline chemicals. The graded media matrix allows small droplets in the incoming gas to merge (coalesce) into larger drops that are easier to separate. All Pall liquid/gas coalescers are chemically treated to lower the surface energy of the medium and promote rapid drainage of the wasted liquids.

*Pall Products: SepraSol® and SepraSol Plus liquid/gas coalescers*



### Liquid / Liquid Coalescers

Pall liquid/liquid coalescers are designed to efficiently separate liquid/liquid emulsions. Constructed of a variety of polymers and fluoropolymers, these high-efficiency coalescers are effective in systems with low interfacial tension without losing performance due to the presence of surfactants (dis-arming). Their long service life means the cartridges require fewer changeouts thereby reducing maintenance and waste disposal costs.

*Pall Products: AquaSep® Plus and PhaseSep® liquid/liquid coalescers*

### Lucid™ Phase Separator

The Lucid separator has the ability to effectively remove gross levels of contaminant water or aqueous fluid in droplet form from liquid phase hydrocarbons and/or conversely, remove contaminant hydrocarbons from water or aqueous solutions.

This new separation technology is simple to install, compact, self-cleaning, and requires no auxiliary utilities, electrostatics, controls, or chemical additives to function. The hardware has no moving parts, is compatible with a broad range of fluids, and is resistant to even the most erosive solids.



### Membrane Technologies

Membrane Technologies are by far the most effective methods for water processing applications. The Pall range of membrane systems includes microfiltration, ultrafiltration and reverse osmosis membrane technology. Pall Aria™ water treatment systems for example use hollow fiber microfiltration membranes to produce pure water from any water source. They remove bacteria, iron, manganese, arsenic, and other solid particulate to deliver water that consistently measures up to the toughest cleanliness and quality standards.

*Pall Products: Pall Aria™ systems, Disc Tube™ Module Reverse Osmosis systems, Membralox® ceramic membranes.*



# Cleanliness Monitoring and System Fluid Contamination Control

Obtaining accurate and reliable fluid cleanliness data quickly in order to detect abnormal contamination is a key factor in ensuring the efficiency of industrial processes and reducing downtime.

## Reliable monitoring solutions ...whatever the conditions ...whatever the fluid

Pall have portable devices that resolve detection problems by giving plant operators the ability to measure the cleanliness of even the most troublesome fluids reliably, simply, and quickly, and prevent unnecessary and costly machinery downtime.

The Pall PCM400W Cleanliness Monitor can confirm cleanliness of almost every kind of system fluid.

The Pall PCM400W uses multiple mesh blockage technology to address the common problem of inaccurate or unreliable results when monitoring fluids that are dark, cloudy, or contaminated by water or air. Additionally it can read fluid temperature and saturated water content (when appropriate).



## Pall Water Sensors

Wherever possible, oils should be operated without the presence of free or emulsified water.

Pall Water Sensors detect water in solution within the fluid, displayed as a percentage saturation or expressed as a parts per million (PPM) reading. Options include the handheld unit for a 'point-in-time' reading or the permanent unit which can provide continuous or timed monitoring.



'Pall' set the standard for high performance hydraulic oil and lube filters in the fluid power industry. The drive for enhanced performance continues with the Pall Ultipleat® SRT filter range for hydraulic oil and lubrication fluids.

## Pall Ultipleat® SRT Filters

### Stress Resistant Technology

The Pall Ultipleat® SRT elements combine an innovative media design and stress resistant media technology to provide the greatest possible overall performance and value.

Features of the **Ultipleat** SRT filter range include:

- **Laid-over Pleating**  
Maximises filter area, Increases flow handling capability and reduces element size
- **Coreless/Cageless Construction**
- **Stress-Resistant Media**  
Excellent resistance to operating system stresses.
- **Auto-Pull filter element removal system**  
Enables simple and quick maintenance of blocked filter elements
- **Anti-static design**  
Minimizes electrostatic charge generation at high flows



## Pall Oil Purifiers

If or when water is detected it can be removed quickly and efficiently using a Pall Oil purifier.

Highly efficient vacuum dehydration separation technology combined with high performance solid particulate filtration purifies fluids such as hydraulic and lube oils, dielectric fluids and fuels.

Pall oil purifiers can extend fluid life by removing 100 % of free water and gases and up to 90 % of dissolved water and gases.





*Our systems can cost  
effectively treat all of the  
incoming process fluids,  
systems fluids, and waste  
streams in your plant*

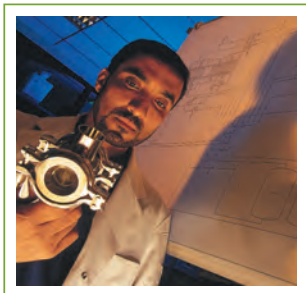

## Research and Development

Working with equipment and component manufacturers in these markets, Pall custom designs products and purification systems that are fully integrated into oil and gas industry applications.

These products extend component service life, enhance safety and improve the operating reliability of all processing systems.



## Scientific and Laboratory Services

A principal element in Pall's customer support operations is our Scientific and Laboratory Services (SLS) Department.

Filtration problems arising in the field can be assessed and simulated in the laboratory. Close monitoring by Pall scientists can determine the engineered solution to your contamination and separation problems and advise accordingly.



## Sales and Support

The sales and support team comprises a group of experienced specialists located in Europe, the USA and across Asia with distributors and representatives worldwide. We offer a comprehensive sales and service support to all customers around the world.

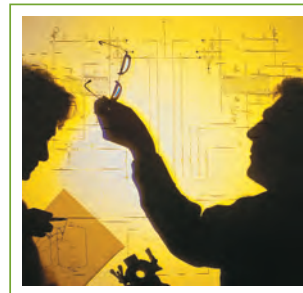

## Quality

The policy of Pall is to design and manufacture products to the highest and most current standards of quality, safety and reliability. To implement this policy, the organisational structure and the procedures by which Pall operates are fully defined in quality management systems, approved to ISO 9001:2000



Pall Corporation

### Fuels and Chemicals

25 Harbor Park Drive  
Port Washington, NY 11050  
+1 516 484 3600 telephone  
+1 888 333 7255 toll free US

Portsmouth - UK  
+44 (0)23 9233 8000 telephone  
+44 (0)23 9233 8811 fax  
industrialeu@pall.com



ENABLING A  
GREENER  
FUTURE<sup>SM</sup>

To see how Pall is helping enable a greener, safer and more sustainable future, visit [www.pall.com/green](http://www.pall.com/green).

### Visit us on the Web at [www.pall.com](http://www.pall.com)

Pall Corporation has offices and plants throughout the world. For Pall representatives in your area, please go to [www.pall.com/contact](http://www.pall.com/contact)

Please contact Pall Corporation to verify that the product conforms to your national legislation and/or regional regulatory requirements for water and food contact use.

Because of technological developments related to the products, systems, and/or services described herein, the data and procedures are subject to change without notice. Please consult your Pall representative or visit [www.pall.com](http://www.pall.com) to verify that this information remains valid. Products in this document may be covered by one or more of the following patent numbers: EP 930,926; US 5,443,724; US 6,332,987; EP 1,165,205; US 6,342,283; US 6,662,842; EP 442,410; US 5,143,614; EP 830,191; US 5,591,335; US 5,653,833; US 5,681,469; US 5,690,782; US 5,730,820; US 5,733,581; US 5,741,395; US 5,783,011; EP 930,926; US 5,480,547; US 6,332,987; EP 433,661; EP 667,800; EP 982,061; EP 1,380,331; US 5,543,047; US 5,690,765; US 5,725,784; US 6,113,784; US 7,083,564; US 7,318,800; EP 470,485; US 5,252,207; US 5,552,048.

© Copyright 2012, Pall Corporation. Pall, , Pall Aria, AquaSep, Claris, Disc Tube, Epopel, LUCID, Membralox, Nexis, PhaseSep, Profile, SeptraSol, Ultipleat and Ultipor are trademarks of Pall Corporation. ® indicates a trademark registered in the USA. ENABLING A GREENER FUTURE and Filtration. Separation. Solution.<sup>SM</sup> are service marks of Pall Corporation.