

Ultipleat® High Flow Filter System

Description

The Ultipleat® High Flow filter is a large diameter, coreless, single open ended, pleated cartridge with an inside-to-outside flow pattern. The filter's unique crescent-shaped pleat geometry, combined with its large 152.4 mm (6 inch) diameter and proprietary range of available Pall filter media, allows you to use significantly fewer filters and smaller housings for high flow rate applications. Systems can handle up to 115,443 lpm (30,500 gpm).

Benefits

- Up to 50% smaller filter system possible
- Up to 40 times fewer elements to change out
- Higher flow rates per filter cartridge – up to 1900 lpm (500 gpm)
- Available in 508 mm (20 inch), 1016 mm (40 inch), 1524 mm (60 inch) and 2032 mm (80 inch) lengths
- Coreless, all plastic construction to minimize waste disposal
- Absolute rated filter medium for reproducible performance
- Inside-to-outside flow configuration – all debris stays within the filter

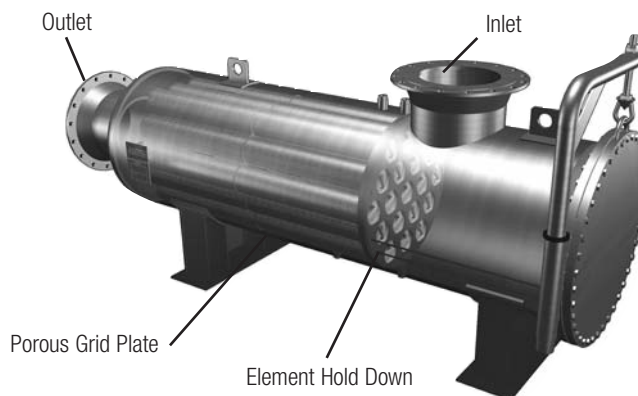

Materials of Construction

Filter Medium Type	Filter Medium	Support/Drainage Materials	End Caps	Wrap Materials
HDC® II Medium	High Area Polypropylene Structure	Polypropylene	Glass Filled Polypropylene	Polypropylene and Polyolefin Hotmelt
Profile® Medium in Ultipleat Format	Pleated Polypropylene Depth Structure	Polypropylene	Glass Filled Polypropylene	Polypropylene
Ultipor® GF Medium	Resin Bonded Glass Fiber / Polyester Support	Polyester / Nylon	Glass Filled Acetal	Polyester and Polyamide Hotmelt
Ultipleat CAS Medium	Pleated Polypropylene / Polyether Sulfone Membrane	Polypropylene	Glass Filled Polypropylene	Polypropylene

Operating Conditions

	Polypropylene Medium/ CAS Composite Medium	Glass Fiber Medium ²
Maximum Differential Pressure ¹ (normal inside to outside flow)	3.4 bar at 82°C/ 50 psid at 180°F	3.4 bar at 121°C/ 50 psid at 250°F

1) For fluids compatible with the filter element at the stated temperature.

2) Maximum temperature in aqueous systems is 60°C / 140°F for GF medium.

Ordering Information

Filter Cartridge Part Number = HFU 1 2 3

Table 1

Code	Filter Dimensions, nominal, diameter (mm/in) x length (mm/in)	Suggested Maximum Water Flow Per Cartridge (lpm/gpm/mgd)
620	152.4/6 x 508/20	663/175/0.25
640	152.4/6 x 1016/40	1325/350/0.5
660	152.4/6 x 1524/60	1900/500/0.7
680	152.4/6 x 2032/80	1900/500/0.7

Filter Cartridge Pressure Drop (typical) per Filter Length Shown²

Table 2

Medium Type	Grade	Liquid Removal Rating (microns) at 99.98% by particle count ¹	20 inch length		40 inch length		60 inch length		80 inch length	
			psid/100gpm	mbar/M ³ /hr	psid/100gpm	mbar/M ³ /hr	psid/100gpm	mbar/M ³ /hr	psid/100gpm	mbar/M ³ /hr
HDC II Medium	J060	6	0.158	0.48	0.080	0.24	0.058	0.17	0.040	0.12
	J100	10	0.120	0.36	0.060	0.18	0.040	0.12	0.030	0.09
	J200	20	0.100	0.30	0.050	0.15	0.033	0.10	0.025	0.08
Profile Medium in Ultipleat Format	UY020 ³	2	1.091	3.31	0.540	1.64	0.362	1.10	0.270	0.82
	UY045	4.5	0.489	1.48	0.242	0.73	0.162	0.49	0.121	0.37
	UY060	6	0.395	1.20	0.196	0.59	0.131	0.40	0.098	0.30
	UY100	10	0.344	1.04	0.170	0.52	0.114	0.35	0.085	0.26
	UY200	20	0.243	0.74	0.120	0.36	0.080	0.24	0.060	0.18
	UY400 ⁴	40	0.182	0.55	0.090	0.27	0.060	0.18	0.045	0.14
	UY700 ⁴	70	0.040	0.12	0.020	0.06	0.013	0.04	0.010	0.03
Ultipor GF Medium	GF020	2	0.219	0.66	0.110	0.33	0.073	0.22	0.055	0.17
	GF060	6	0.180	0.55	0.090	0.27	0.060	0.18	0.045	0.14
	GF100	10	0.159	0.48	0.080	0.24	0.053	0.16	0.040	0.12
	GF200	20	0.119	0.36	0.060	0.18	0.040	0.12	0.030	0.09
	GF400 ⁴	29	0.100	0.30	0.050	0.15	0.033	0.10	0.025	0.08
Ultipleat CAS Medium	CAS010	1	1.496	4.54	0.740	2.25	0.496	1.51	0.370	1.12

¹ The test procedure used is an adaptation of ISO 4572, modified to determine the micron size above which particles are quantitatively removed.

² Multiply this value by the total system flow to determine the aqueous pressure drop. For fluids other than water, multiply this value by the fluid's viscosity at the operating temperature in centipoise. This value is the pressure drop across the Ultipleat® High Flow filter(s) only; it must be added to the pressure drop contribution from the Ultipleat High Flow filter housing.

³ 2 micron at 99% efficiency.

⁴ Precision evaluation of the 99.98% removal efficiency for these coarse grades is not possible with the ISO modified test procedure utilized. The removal efficiency was determined by the maximum spherical particle analysis.

Table 3

Code-Filter O-Ring	Material
H13 (standard for glass fiber and aramid fiber filters)	Nitrile
H13U ⁵	Nitrile U-Cup
J (standard for polypropylene filters)	Ethylene propylene
JU ⁵	Ethylene propylene U-Cup
H4	Silicone
H	Fluoroelastomer

⁵ U-Cup seal is standard for the 1 micron composite filter.

Housing Design

Three configurations are available: horizontal⁶, vertical and centerpipe design.

The in-line horizontal configuration eliminates the need for a platform, or ladder, to remove the filters from the housing.

Vertical vessels may be more appropriate when floor space is limited. However, a platform may be needed to easily remove the elements.

⁶ Required for 80 inch lengths.

In both the standard horizontal and vertical configurations, the inlet pipe is located between the filter element tubesheet and housing lid. The larger the vessel diameter, the longer the distance to reach in and remove the elements from the vessel. In a centerpipe vessel the housing lid is closer to the filter tubesheet. When the lid is opened the filters are easily accessible for installation and removal. Centerpipe vessels are larger in diameter, and more costly.

- Designed to the ASME, section VIII, division 1 code
- Maximum differential pressure across tubesheet: 5.17 barg (75 psid) maximum
- Standard housing gasket: spiral wound 304 stainless steel mineral fiber
- Carbon steel exterior surfaces: sandblasted and coated with an inorganic zinc
- Vent and drains: 1 inch FNPT
- Corrosion allowance: 1/8 inch

Housing Ratings

Vessel Material	Tubesheet and Hold Down Plate Material of Construction	Pressure Rating in Barg/Psig at 60°C / 140°F
Carbon steel	304 stainless steel	18.95 bar (275 psig)
304 stainless steel	304 stainless steel	17.85 bar (259 psig)
304L stainless steel	304L stainless steel	14.89 bar (216 psig)
316 stainless steel	316 stainless steel	17.99 bar (261 psig)
316L stainless steel	316L stainless steel	14.89 bar (216 psig)

Filter Installation and Filter Seal Mechanism

To install a filter element, remove the element hold down plate by lifting it off the locating pins. Lubricate the O-ring on the open-end of the filter with a compatible fluid, and slide the closed end of the filter into the perforated cage, which is welded to the tubesheet. Seat the elements in place by pressing down on the open-end of the filter until the element is snug in the tubesheet. This provides a seal between the filter and housing via the filter O-ring. The open-end cap must be below the tubesheet surface. After installing all the filter cartridges,

reinstall and secure the element hold down plate by guiding it over the locating pins on the tubesheet. The purpose of the hold down plate is to prevent the elements from becoming dislodged in the event of reverse flow.

A filter element tool is provided with each housing to aid with the installation and removal of the filter cartridges. This tool eliminates the need for an operator to reach within the filter vessel to either remove or install filters.

Figure 1: Ultipleat High Flow Horizontal Housings (Aqueous Housing Pressure Drop)

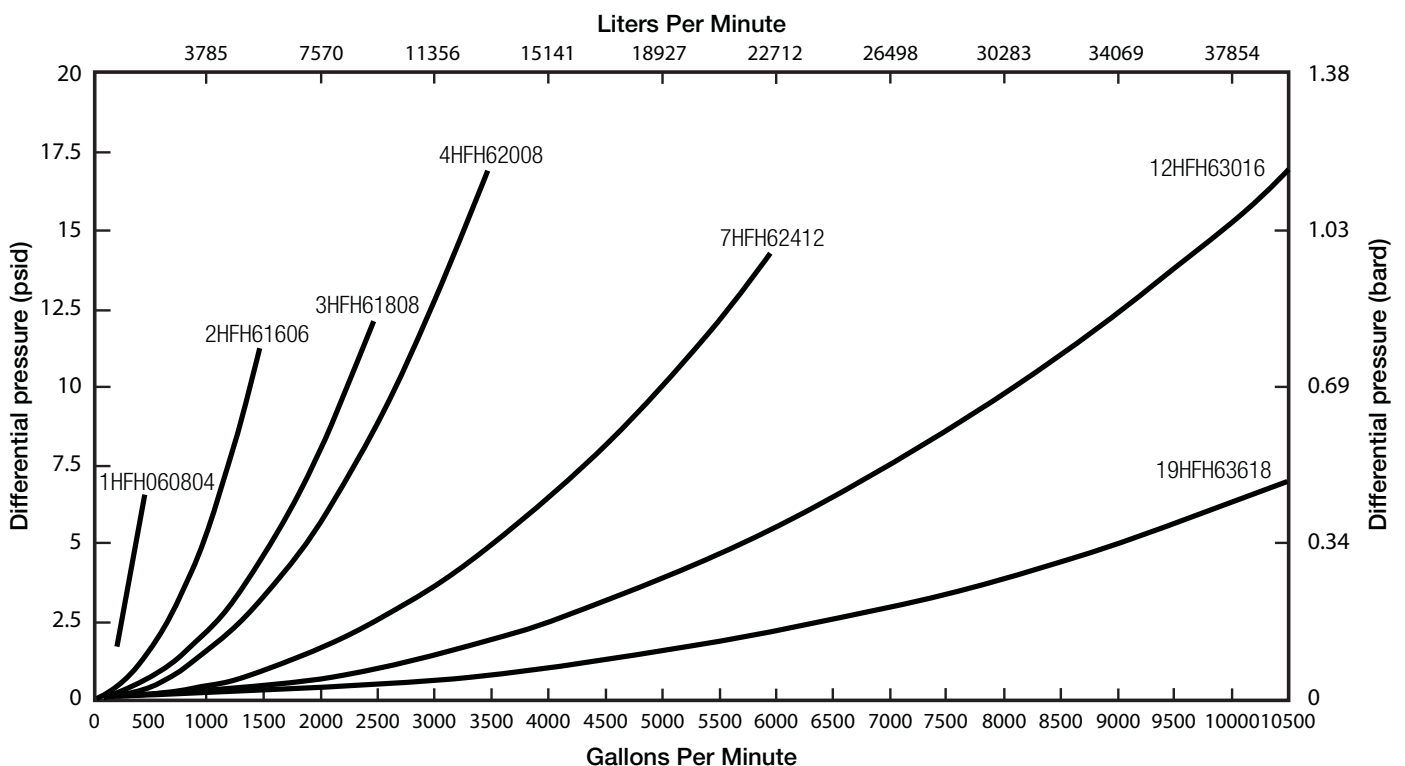

Ordering Information-Standard Horizontal and Vertical Housings

Part Number	No. of Filters	Rated Flow Per Housing- LPM/GPM 60 in Long Filter	Nominal Housing Diameter (mm/in) (D)	Inlet/Outlet Flange Diameter (mm/in)	Maximum ⁷ Horizontal Housing Overall Length (mm/in) (L)	Horizontal Housing Height (mm/in) (H)	Distance Between Housing and Lid and Tubesheet (mm/in)	Housing ⁷ Weight Empty (kg/lbs)	Housing ⁷ Weight Full of Water (kg/lbs)	Housing Cover Swing Opening (mm/in)
1HF 1 2 0804F1 3 4	1	1893/500	219.1/9	101.6/4	2261/89	817/32	368.3/14.5	214/471	282/621	228.6/9.0
2HF 1 2 1606F1 3 4	2	3785/1000	406.4/16	152.4/6	2527/100	1023/40	576.3/22.7	532/1172	803/1771	654.6/25.8
3HF 1 2 1808F1 3 4	3	5680/1500	457.2/18	203.2/8	2642/104	1093/43	665.2/26.2	718/1583	1081/2384	692.8/27.3
4HF 1 2 2008F1 3 4	4	7570/2000	508.0/20	203.2/8	2654/105	1175/46	669.6/26.4	947/2087	1382/3048	756.3/29.8
7HF 1 2 2412F1 3 4	7	13248/3500	609.6/24	304.8/12	2832/112	1487/59	809.6/31.9	1474/3250	2160/4762	870.6/34.3
12HF 1 2 3016F1 3 4	12	22710/6000	762.0/30	406.4/16	3073/121	1480/58	982.7/38.7	2118/4670	3314/7306	964.9/38.0
19HF 1 2 3620F1 3 4	19	35958/9500	914.4/36	508.0/20	3264/129	1718/68	1101.6/43.4	3202/7060	5045/11121	1138.8/44.8

Ordering Information - Horizontal Orientation, Centerpipe Designed Housings

Part Number	No. of Filters	Rated Flow Per Housing- LPM/GPM 60 in Long Filter	Nominal Housing Diameter (mm/in) (D)	Inlet/Outlet Flange Diameter (mm/in)	Maximum ⁷ Horizontal Housing Overall Length (mm/in) (L)	Horizontal Housing Height (mm/in) (H)	Distance Between Housing and Lid and Tubesheet (mm/in)	Housing ⁷ Weight Empty (kg/lbs)	Housing ⁷ Weight Full of Water (kg/lbs)	Housing Cover Swing Opening (mm/in)
7HF 1 C 2 2808F1 3 4	7	13248/3500	711/28	203.2/8	2648/104.3	1448/57.0	124/4.9	1840/4056	2825/6229	914/36
8HF 1 C 2 3012F1 3 4	8	15140/4000	762/30	304.0/12	2988/117.6	1480/58.3	154/6.1	2135/4707	3333/7348	1018/40

⁷ For 60 inch filter lengths

Table 1

Code	Housing configuration
H	Horizontal
V	Vertical

Table 2

Code	Nominal cartridge length (mm/in)
2	508/20
4	1016/40
6	1524/60
8	3032/80

Table 3

Code	Housing metallurgy
285	Carbon steel vessel, 304 stainless steel tubesheet
S3	304L stainless steel
S8	304 stainless steel
L3	316L stainless steel
L8	316 stainless steel

Table 4

Code	Optional outlet size ⁸ horizontal housings
XU	Upper outlet location
XL	Lower outlet location

⁸ If the housing is to be used as a prefilter to a horizontal liquid/liquid coalescer, then the vessel should be ordered using the XU or XL option for the outlet location. The orientation of the outlet should be the same as that of the sump on the coalescer. In this way no buildup of coalesced liquid will occur in the prefilter.

Horizontal Housings

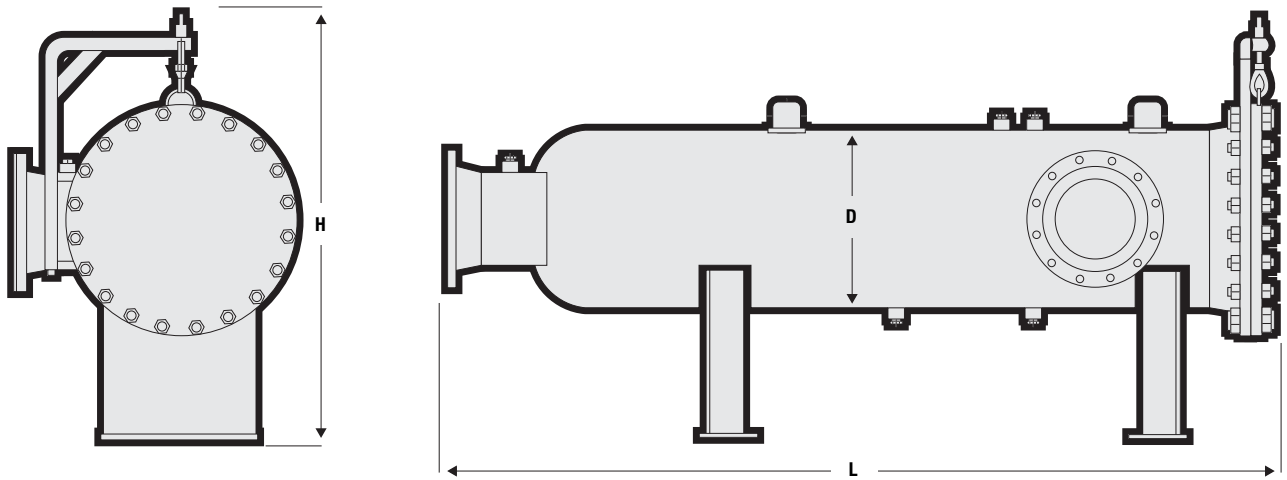

Horizontal Housings, Centerpipe Design

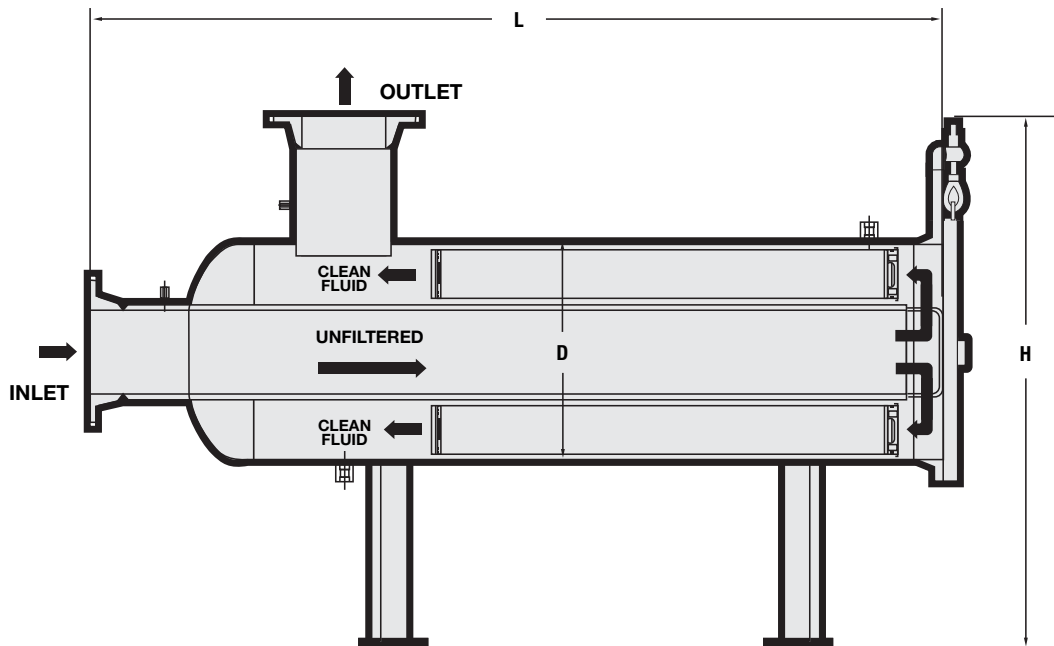

Ultipleat High Flow Filter System Reduces Costs

Begin reducing your capital and operating costs today. Contact your local Pall distributor or call Pall directly for an Ultipleat High Flow filter system quotation.



25 Harbor Park Drive
Port Washington, NY 11050
+1 516 484 3600 telephone
+1 800 289 7255 toll free US

Portsmouth – UK
+44 (0) 23 9233 8000 telephone
+44 (0) 23 9233 8811 fax
industrialeu@pall.com



Visit us on the Web at www.pall.com

Pall Corporation has offices and plants throughout the world. For Pall representatives in your area, please go to www.pall.com/contact.

Because of technological developments related to the products, systems, and/or services described herein, the data and procedures are subject to change without notice. Please consult your Pall representative or visit www.pall.com to verify that this information remains valid. Products in this document may be covered by one or more patent numbers. For a complete list of Pall's patents please visit www.pall.com/main/about-pall/patents.page.

© Copyright 1999, 2015 Pall Corporation. Pall, , HDC, Profile, Utleplet, and Ultipor are trademarks of Pall Corporation.

® Indicates a Pall trademark registered in the USA. **Filtration. Separation. Solution.SM** and **BETTER LIVES. BETTER PLANET.** are service marks of Pall Corporation.