

Continuous Filtration without Filter Aid

The Pall ZEF Contiflux® Filtration System

Introduction

There is an increasing demand for improved economy and product quality in solid liquid separation processes. These requirements are met by a continuous mechanical separation process used in the Pall ZEF Contiflux® filtration system.

Principles of Operation

Rotating filter elements and fixed scrapers which allow the level of concentrated solids developing above a defined 'cake' height during each rotation, to be scraped off and discharged to waste.

Due to the rotation of the filter elements, the scraped off cake is resuspended and then, depending on the required solid consistency, discharged out of the pressure vessel or returned in order to increase the degree of concentration. The scrapers may be adjusted in height (on request), leave a product-related minimum residual cake coating which guarantees a constantly high separation effect.

The Pall ZEF Contiflux® filtration system allows an exact control of the filter cake resistance and of the differential pressure.

Characteristics

- Continuous filtration of suspended solids
- Concentration of solids
- Enclosed filtration process
- Direct filtration without filter aids
- Separate product feed for each filter element
- Defined filter cake height
- Rotating filter elements
- Fully automated filtration process
- High pressure cleaning in place for individual filter elements

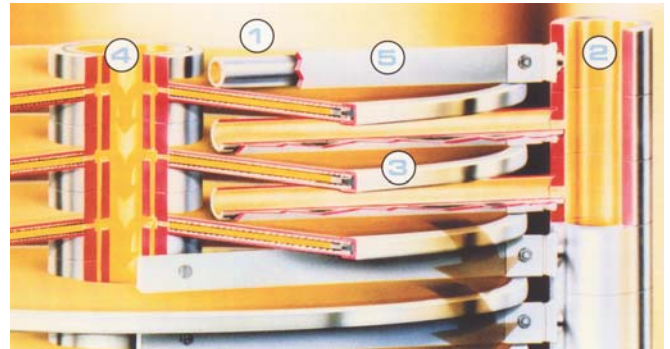

Sectional drawing of the Pall ZEF Contiflux® filter

Operating Method

The suspension is distributed over the rotating filter elements (3) by a series of distribution pipes (1), fed by a common feed pipe (2). Solids separation and filtrate flow into the central filtrate collection shaft (4) is achieved by the pressure difference.

The level of filter cake developing on the rotating filter elements is limited by the scraper blades (5) to a cake height. The concentrated suspension is discharged from the ZEF filter and can be returned to the process if required.

ZEF Contiflux® Images

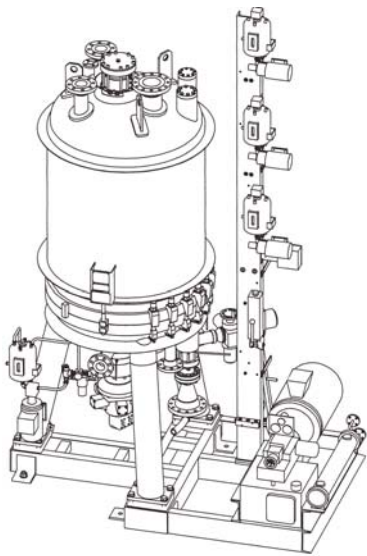

Outline 3D drawing



Completely mounted



With opened vessel

Standard Sizes and Technical Specifications

		ZEF-14	ZEF-18	ZEF-21	ZEF-25	ZEF-30	ZEF-32	ZEF-35	ZEF-40	ZEF-45	ZEF-50
Quantity of filter plates	pieces	10	13	15	18	22	23	25	29	32	36
Filter area	m ²	14.0	18.2	21.0	25.2	30.8	32.2	35.0	40.6	44.8	50.4
Vessel volume, equipped	m ³	1.16	1.36	1.50	1.70	1.97	2.04	2.17	2.44	2.65	2.92
Height of vessel	mm	2900	3098	3230	3428	3692	3758	3890	4154	4352	4616
Width of rack	mm	1650									
Length of rack	mm	2900									
Operating pressure	bar(g)	maximum standard: -1 /20									
Operating temperature	°C	maximum standard: 200									
Drive	-	hydraulic/electric, stepless adjustable speed from 5 to 130 rpm, EExd IIC T3									
Power electrical motor	kW	37					55				

Applications

- Catalyst recovery / recirculation
- Thickening of suspension
- Toluylendiisocyanat process
- Butynediol / Butanediol process
- Anilin process



Pall Corporation

Pall Fuels and Chemicals

New York - USA
 +1 516 801 9906 telephone
 +1 888 428 5597 toll free
 +1 516 484 6247 fax

Portsmouth - UK
 +44 (0)23 9230 3303 telephone
 +44 (0)23 9230 2507 fax

Visit us on the Web at www.pall.com

Pall Corporation has offices and plants throughout the world. For Pall representatives in your area, please go to www.pall.com/corporate_contact.asp

Because of technological developments related to the products, systems, and/or services described herein, the data and procedures are subject to change without notice. Please consult your Pall representative or visit www.pall.com to verify that this information remains valid.

© Copyright 2009, Pall Corporation. Pall,  and Contiflux are trademarks of Pall Corporation. ® Indicates a trademark registered in the USA. Filtration. Separation. Solution.SM is a service mark of Pall Corporation.