



Industrial Process

Scientific & Technical Report

TP-PP3a

Validation of Integrity Test Values For Cleanable Porous Stainless Steel Polymer Filters

Scientific & Technical Report

Validation of Integrity Test Values For Cleanable Porous Stainless Steel Polymer Filters

Tore H. Lindstrom, Ph.D., Staff Scientist, Scientific and Laboratory Services Department, Pall Corporation

Presented at the American Filtration Society (Annual Meeting) March 18-22, 1990 Arlington, Virginia

Abstract

Most filter applications in the polymer industry have a critical impact on product quality, and as a user it has become more and more important to be able to predict in-service performance of a new or cleaned filter assembly prior to actual installation. One important characteristic of such a filter assembly is integrity. This paper addresses the commonly used method of 1st Bubble Point Determination, for integrity evaluation.

In order to draw conclusions regarding the information obtained by 1st Bubble Point Determination, three bubble pointed, 7" diameter powder metal segments were subjected to a F-2 Filter Performance Test. To obtain a sub-specification value for one segment, a 0.0145" diameter hole was drilled (through the medium

on one side of the segment and into the drainage layer in the center of the segment).

The value of the 1st Bubble Point measurement for a filter assembly provides important integrity information because the maximum attainable filter efficiency will be finite if the 1st Bubble Point falls below a threshold value (between 0.5 and 9.1 "wc, for the segments evaluated in this study).

A minimum acceptable 1st Bubble Point value (ensuring a desired filter removal at a particle size) can be determined. This threshold value will be dependent on several parameters (i.e. viscosity and density of fluid filtered, terminal pressure differential, flowrate, and accuracy of by-pass path model).

Background

Most filter applications, in the polymer industry, have a critical impact on product quality. A number of these applications involve the use of cleanable porous metal filter assemblies (pleated candles or segments) to high pressure differentials (1500 psid is not unusual). As a user it has become more and more important to be able to predict in-service performance of a new or cleaned filter assembly prior to actual installation. Evaluations of these filter assemblies should be simple, quick and inexpensive. One important characteristic of the filter assembly is integrity.

This paper addresses a commonly used method of 1st Bubble Point Determination (see Appendix D). It should be noted that this method will not be able to detect certain failures, such as loss of sinter bonds, since the associated change in pore sizes (fiber deformation, etc.) is undetectable at low pressure differentials.

Test Procedures and Results

In order to draw conclusions regarding the information obtained by 1st Bubble Point Determination, three (S/N's: A1, A2, and A3) 7" diameter powder metal segments were subjected to 1st Bubble Point Determination followed by a F-2 Filter Performance Test (see Appendix II).

F-2 testing does not destroy (irreversibly alter) the filter assembly under evaluation, but the evaluated assembly will require cleaning after the test, due to retained test contaminant.

The three segments to be tested all passed quality assurance requirements for 1st Bubble Point. In order to obtain a sub-specification value, for segment A1, a 0.0145" diameter (368 μ m) hole was drilled through the medium on one side of the segment and into the drainage layer in the center of the segment.

The following bubble point values were obtained for the segments in question:

S/N	1st Bubble point (" water column)	Remark
A0	9.1 "wc	Without hole
A1	0.5 "wc	A0 with 368 μ m hole
A2	13.3 "wc	
A3	9.1 "wc	

The measured Bubble Point values are also shown in Figure 1. A 1st Bubble Point of 0.5 "wc (segment A1) is equivalent to a straight cylindrical pore with a diameter larger than 238 μ m, based on the Bubble Point formula (Appendix I) with a displacement coefficient (δ) of 238 (straight cylindrical pore), and an accuracy of ± 5 "wc (at the low end of the pressure scale).

Figure 1
1st Bubble Point Values For 7" Diameter Powder Metal Segments S/N: A1, A2, A3

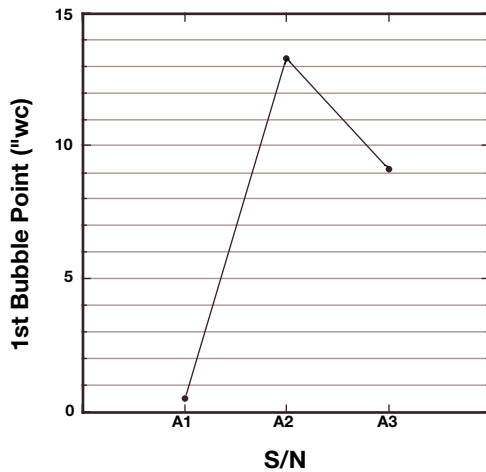

Figure 2
Time Average β -Ratio Versus Particle Size For 7" Diameter Powder Metal Segment (S/N:A1)

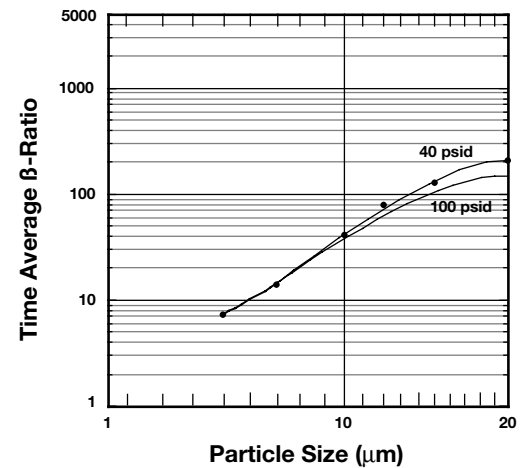

Figure 3
Time Average β -Ratio Versus Particle Size For 7" Diameter Powder Metal Segment (S/N:A2)

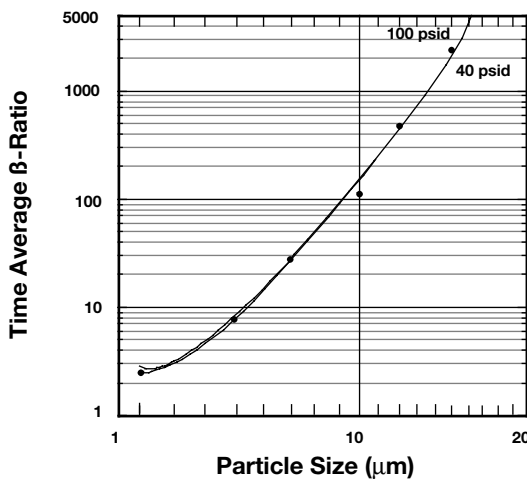
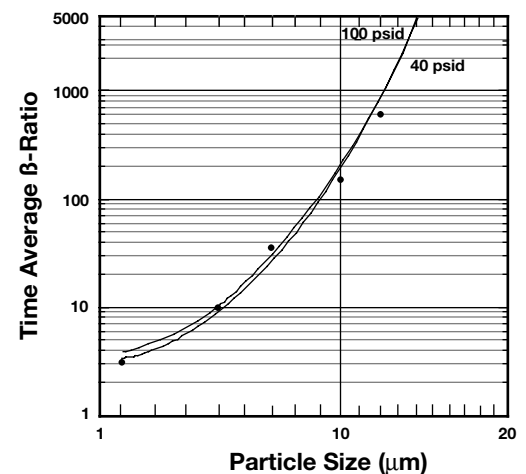

Figure 4
Time Average β -Ratio Versus Particle Size For 7" Diameter Powder Metal Segment (S/N:A3)



F-2 filter efficiencies (see Appendix II) obtained for each of the three segments (time averaged to 40 and 10 psid) are shown in Figures 2 through 4.

The following observations can be made in these figures:

- The sub-specification segment (A1) shows a leveling off of the removal curve at a finite β -ratio (140-200).
- The removal curves of the other segments (A2 and A3) becomes infinite (>5000) at a particle size below 20 μm .
- When comparing the efficiency curves to 40 and 100 psid, one can see that only the sub-specification segment (A1) shows lower efficiency values to a higher pressure.

These observations are consistent with the presence of a by-pass (a path for the fluid around but not through the media) in segment A1.

The efficiency (β -ratio) of a filter without a by-pass can be calculated as follows:

$$\beta_x^* = \frac{N_u}{N_d} \quad \text{Where:} \quad \begin{array}{l} N_u = \# \text{ of upstream particles} \\ \text{(larger than } x \mu\text{m)} \\ N_d = \# \text{ of downstream particles} \\ \text{(larger than } x \mu\text{m)} \end{array}$$

If a by-pass is present this relationship changes to:

$$\beta_x^* = \frac{N_u}{\alpha N_u + (1-\alpha)N_d} = \frac{1}{\alpha + \frac{(1-\alpha)}{\beta_x}}$$

Where: α = ratio between by-pass and total flow.

If the limiting particle size, x , is set high enough (20 μm for the evaluated segments) the filter efficiency, β_x , becomes infinite and the filter efficiency measured in the presence of a by-pass, β_x^* , becomes $1/\alpha$.

The measured β (where x is 20 μm) for segment A1 as a function of test duration can be found in Figure 5. If this data is combined with the differential pressure (ΔP) across the segment during the same test (shown in Figure 6) β can be presented as a function of ΔP (shown in Figure 7).

Based on the geometry of the hole (a simple cylinder) the following derivation can be made of the by-pass ratio:

$$\alpha = \frac{Q_{bp}}{Q_{tot}} \quad \text{Where:} \quad \begin{array}{l} Q_{tot} = \text{total flow (8.2 l/min,} \\ \text{for segment A1)} \\ Q_{bp} = \text{by-pass flow} \\ = \frac{\pi * d^4 * \Delta P}{128 * l * \mu} \end{array}$$

Where: d = diameter of hole
 ΔP = differential pressure
 l = length of hole (1/16", for A1)
 μ = viscosity of fluid (13.95 cP, for A1)

This can be reduced to a linear function:

$$\alpha = C * \Delta P = 1/\beta$$

$$\text{Where: } C = \frac{\pi * d^4}{128 * l * \mu * Q_{tot}}$$

Figure 5
 β -Ratio ($>20\mu\text{m}$) Versus Challenge Duration For 7" Diameter Powder Metal Segment (S/N:A1)

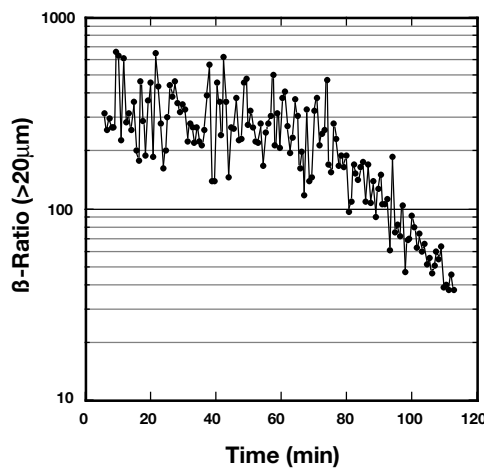

Figure 6
 ΔP Versus Challenge Duration For 7" Diameter Powder Metal Segment (S/N:A1)

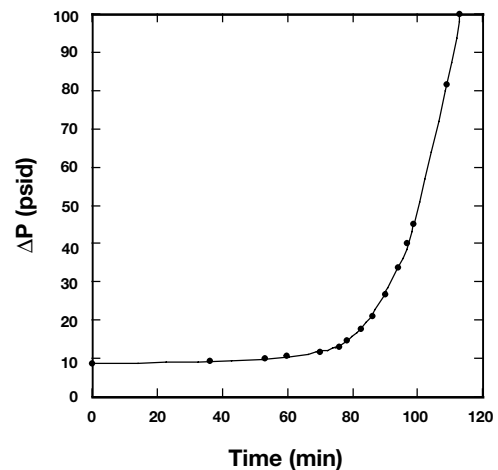

Figure 7
 β -Ratio (>20 μm)
 Versus ΔP For 7" Diameter Powder Metal Segment (S/N:A1)

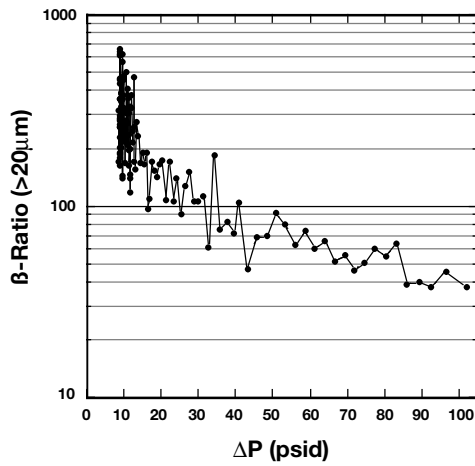

Figure 8
 $1/\beta$ (>20 μm) Versus ΔP For 7" Diameter Powder Metal Segment (S/N:A1)

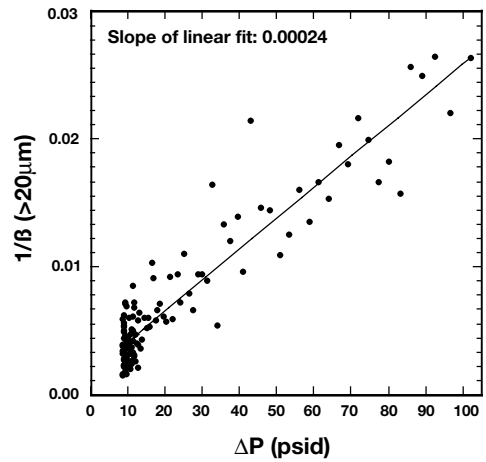

Figure 9
 β -Ratio (>20 μm) Versus ΔP For 7" Diameter Powder Metal Segment (S/N:A1)

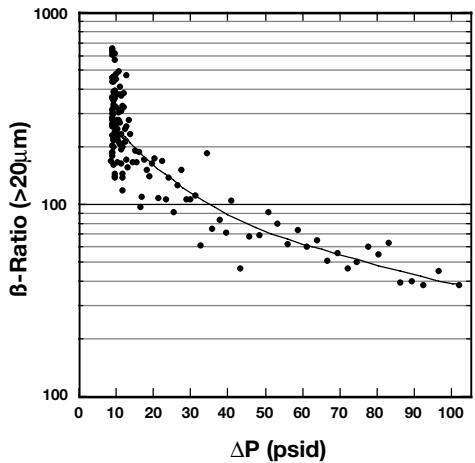
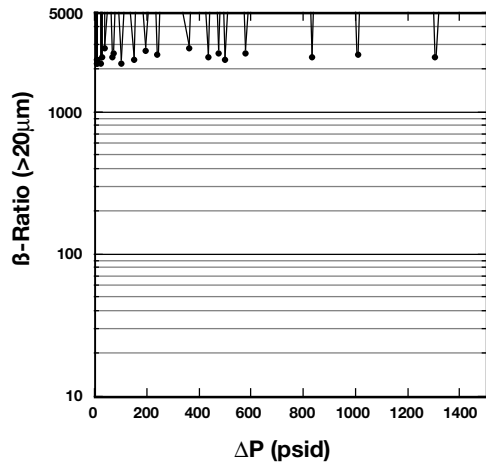

Figure 10
 β -Ratio (>20 μm) Versus ΔP For 7" Diameter Powder Metal Segment (S/N:A3)



In Figure VIII $1/\beta$ (>20 μm) for segment A1 is shown as a function of ΔP . It should be noted that the spread in the data points are due to the statistical nature of the particle counting. A linear fit provided a value of 0.00024 psid⁻¹ for C. Based on this value the size of the hole is estimated at 256 μm .

Figures 10 and 11 show the β -ratio (>20 μm) for segments A2 and A3 respectively. As can be seen the β -ratio (> 20 μm) for neither of these segments shows a decline with increasing pressure differential, even to 1500 psid. The occasional low values (<5000) are again due to the statistical nature of the particle counting process.

The deviation between this value and the known diameter of the drill used (368 μm) can be explained by the hole being obtained by drilling into the drainage layer and the clearance between this drainage layer and the medium being unknown. The flow through the hole could be restricted by the opening between the drainage layer and the medium, if this clearance is significantly small.

A curve of threshold values versus differential pressure can be obtained based on: a specific flow rate, a specific fluid (viscosity), a desired filter efficiency (for particles larger than the absolute rating of the filter assembly), and a model of the by-pass path. An example of such a curve is shown in Figure 12.

Figure 9 shows the β -ratio (>20 μm) for segment A1 as a function of ΔP . Superimposed on the data points is a curve showing infinite filtration efficiency based on the assumption that there is a cylindrical by-pass with a diameter of 256 μm .

This particular curve is based on the following criteria:

- Fluid: Polymer
- (at 575°F, $\mu=2000$ P and $\rho =1.2$ kg/liter)
- Flow rate: 0.053 liter/min
- (20 lbs/hr/ft², and 0.42 ft² per 7" segment)
- Minimum filter efficiency: 99.98% ($\beta=5000$)
- By-pass path model: Straight cylinder (1/16 " long)

Figure 11
 β -Ratio (>20 μ m)
 Versus ΔP For 7"
 Diameter Powder
 Metal Segment
 (S/N:A3)

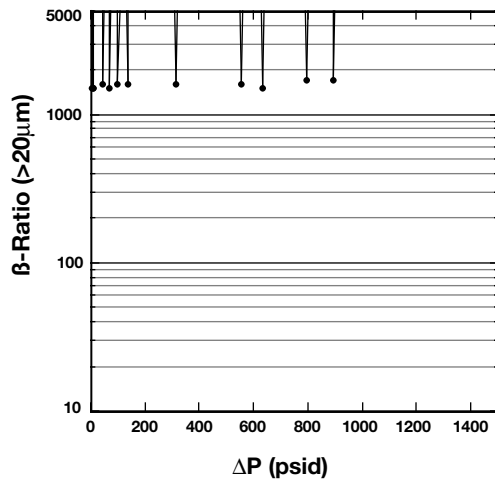
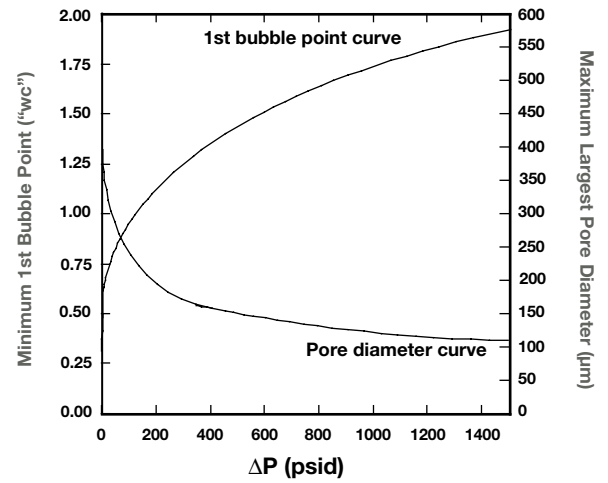

Figure 12
 Theoretical 1st
 Minimum Bubble
 Points and
 Maximum Largest
 Cylindrical Pore
 Diameter For
 Filtration of a
 Polymer at 575° F,
 2000 Poise, 1.2
 kg/Liter and 0.053
 Liter/Minute While
 Requiring a
 Minimum β -Ratio of
 5000 For Particles
 Larger Than the
 Absolute Rating of
 the Filter.



Conclusions

The value of the 1st Bubble Point measurement for a filter assembly provides important integrity information since the maximum attainable efficiency will be finite (if the 1st Bubble Point falls below a threshold value between 0.5 and 9.1 ″wc, for the segments evaluated in this study).

A minimum acceptable 1st Bubble Point value (ensuring a desired filter removal at a particle size) can be determined. This threshold value will be dependent on several parameters (i.e. viscosity and density of fluid filtered, terminal pressure differential, flowrate, and accuracy of by-pass path model).

APPENDIX I

1st Bubble Point Determination

Theoretical Derivation

When there is a difference in gas pressure between two sides of a fully wetted (i.e. all pores completely filled with liquid) porous material, a balance exists between the surface tension of the liquid and the exerted gas pressure. As the pressure differential is increased, the gas will strive to displace the wetting liquid in some of the pores.

To simplify the derivation and form of a formula for this displacement the following assumptions are necessary:

1. The pores are simple cylinders.
2. Complete wetting occurs between porous material and wetting liquid (i.e. all pores are completely filled with wetting liquid).
3. The increase of pressure differential from none, (fully wetted material) to the point where a measurement is to be taken is made so slowly

that surface tension and pressure forces are always in balance.

4. The flow through the porous material and as a result the friction losses in the medium are negligible.

Based on these assumptions the relationship between pore diameter and pressure differential can be written as:

$$\Delta P = \frac{4 \cdot S}{d}$$

Where: ΔP = Differential pressure
 S = Liquid surface tension
 d = Pore diameter

Deviations from the above mentioned assumptions results in a more commonly used relationship:

$$\Delta P = \frac{\delta}{d}$$

Where: δ = Displacement coefficient dependent on medium makeup, pore geometry, wetting, and gas and liquid composition.

As can be seen the pressure differential is inversely proportional to the pore diameter (of a pore where the liquid is being displaced). When an increasing pressure differential is exerted across a porous material the liquid in the largest pores will be displaced first, and the liquid in the smallest pores last.

Figure 1-A
Schematic of
Measuring System
for Bubble Points

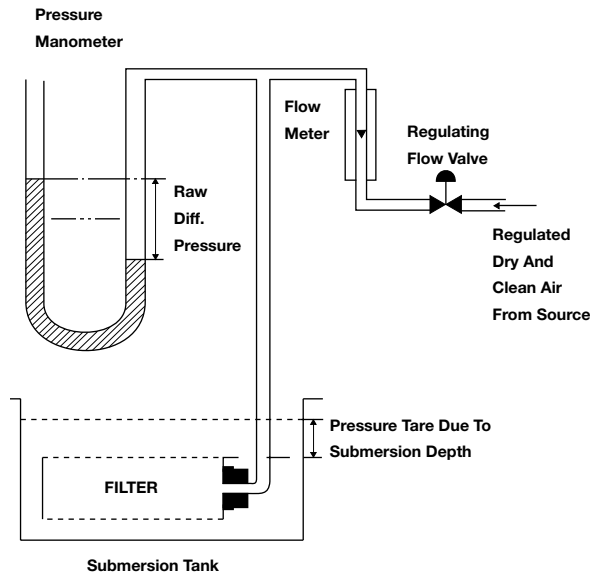

The displacement coefficient, δ , is a constant, as long as the pressure differential associated with flow, through the porous material, is negligible when compared to that of liquid displacement.

Test Procedure

1. Assemble a measuring system equivalent to that in Figure 1-A.
2. Fully wet the filter assembly (element or segment) with the wetting liquid.
3. Submerge the filter assembly in the wetting liquid.
4. Connect test adapter to the filter fitting and seal any other filter openings. This should be done such that the gas is allowed to enter inside the filter assembly and displace the liquid out through the medium.
5. Slowly increase the pressure differential until the first stream of bubbles can be detected, while continuously rotating or turning the filter assembly (so that the entire filter surface has been subjected to the minimum submersion depth at each pressure differential setting), and record the pressure differential when this occurs (see interpretation of results).

6. Calculate the corrected pressure differential by subtracting the immersion depth in the fluid, as a static pressure. The corrected pressure differential is dependent on the temperature and the type of liquid used. Known surface tensions for different liquids at different temperatures can be used to convert the measurement to a value for a different liquid and/or a different temperature.

$$\Delta P_2 = \frac{S_2}{S_1} \cdot \Delta P_1$$

Where: S_x = Surface tension liquid #x, @ temp, t_x
 ΔP_x = Diff. pressure for liquid #x, @ temp. t_x

Interpretation of Results

A Bubble Point measurement is dependent on: medium make-up (material), pore geometry, wetting, gas and liquid composition, and temperature. As a result care should be taken when using Bubble Point values for comparisons.

Unless careful correction can be made (extremely complicated) for all of the above mentioned parameters, *comparison of Bubble Point values should be restricted to the same filter assembly and medium type.*

Based on the theoretical relationship presented above, the 1st Bubble Point value is related to the largest pore in the filter assembly, and, as a result, *can be used as a quality control measurement of a medium and filter assembly integrity.* Small flaws in medium and seals in the filter assembly can be detected by a low 1st Bubble Point value.

Since most porous media have some form of bell-shaped pore size distribution and the 1st Bubble Point measurement is related to the size of the largest pore, *the validity of use for anything but integrity verification is questionable.*

References

1. Aerospace Recommended Practice, ARP 901 (1968), *Bubble Point Test Method*, Society of Automotive Engineers, Inc., Warrendale. Theoretical derivation of and test instructions for bubble-point determination.

F-2 Filter Performance Test

Background

The F-2 Filter Performance Test establishes the degree of efficiency of a filter and its contaminant capacity. This is achieved by providing a continuous supply of ingressed contaminant and allowing constant monitoring of the performance characteristics of the filter.

Figure 2-A
Schematic of Test Apparatus

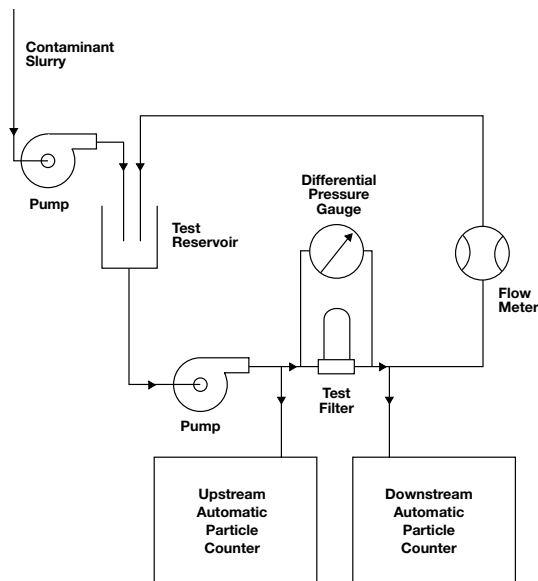

The test procedure employed is an adaptation of the “Oklahoma State University F-2 Filter Performance Test”, adopted by the American National Standards Institute as their approved procedure ANSI B93.31-73. The original procedure was developed for the evaluation of hydraulic filters, but has been modified for the rapid, semi-automated testing of filters with aqueous liquids in single pass mode.

The scope of the test includes a single pass filtration performance test with continuous contaminant injection in aqueous media and determination of the filter contaminant capacity and particulate removal characteristic at various pressures.

A typical F-2 test apparatus is schematically represented in Figure II-A.

The aqueous test procedure employs a test contaminant prepared from AC Fine Test Dust

(ACFTD), an irregularly shaped, naturally occurring siliceous dust used as a standard in many industries and specified in the original procedure. ACFTD is dispersed in water by a Cowless mixer and then agitated with an air driven “Lightning” mixer for 4-6 weeks. This procedure overcomes the difficulty of achieving a reproducible dispersion via less vigorous methods of mixing.

Two automatic particle systems are installed to monitor, in-line, the contaminant level of particles of interest upstream and downstream of the filter under evaluation.

Procedure

1. The test is started by setting a required flow rate through the test filter housing. In general a test flow of 10 LPM per 10” filter element is recommended.
2. While the clean water is recirculated, particle counting equipment monitors the number of particles present. As the water passes through the system clean-up filter (usually rated at 0.2 μm), the number of particles present in the recirculation stream decreases and finally reaches a predetermined low level of particles in each size range. This is known as blanking out the system.
3. After the required cleanliness of the system is achieved, the test filter is installed in the test housing, followed by bleeding the system of air.
4. A slurry contaminant tank is charged from a stock suspension, with a known concentration and constant size distribution. The slurry concentration is based upon the expected upstream gravimetric level desired test duration and injection flow rate.
5. The differential pressure across the filter is established while running clean water through the filter at the specified flow rate.
6. The test filter is challenged with the contaminant by injection into the recirculation loop.

7. Filtration efficiency is determined with two automatic particle counters installed in-line, each equipped with a particle sensor. Particle counts are obtained simultaneously at six different particle diameters. Upstream and downstream counts are recorded automatically (upstream and downstream of the test filter) at each of the designated particle diameters.
8. All test parameters are held constant while the pressure drop across the test filter and test time is being monitored.
9. When the pressure across the filter reaches a specified terminal differential pressure, the test is terminated.

The automatically recorded particle counts (upstream and downstream of the filter) permit the calculation of beta efficiency, or filtration ratio, over the course of the test, as follows:

$$\beta_x = \frac{N_u}{N_d} \quad \text{Where: } \begin{array}{l} \beta = \text{Filtration ratio @ } x \\ N_u = \# \text{ of part. upstream } > x \\ N_d = \# \text{ of part. downstream } > x \\ x = \text{Particle diameter } (\mu\text{m}) \end{array}$$

A reciprocal time average of the beta efficiencies throughout the test is calculated, for each particle size evaluated, and a contaminant holding capacity is determined.



Industrial Process

2200 Northern Boulevard
East Hills, New York 11548-1289

888.873.7255 toll free
516.484.5400 phone
516.484.0364 fax

Visit us on the web at www.pall.com

Select-A-FAX* 800.664.7255

for the latest information delivered to any fax machine, anywhere in the world. This automatic system operates 24 hours a day, seven days a week. Call 1.516.942.0523 from outside the USA.

Pall Corporation has offices and plants throughout the world in locations including: Argentina, Australia, Austria, Belgium, Brazil, Canada, China, France, Germany, Hong Kong, India, Indonesia, Ireland, Italy, Japan, Korea, Malaysia, Mexico, the Netherlands, New Zealand, Norway, Poland, Puerto Rico, Russia, Singapore, South Africa, Spain, Sweden, Switzerland, Taiwan, Thailand, United Kingdom, United States, and Venezuela. Distributors are located in all major industrial areas of the world.