

MODEL	'X'	SHELL DIA.	'A'	'B'	'C'	'D'	'E'	'F'	'G'	'H'
FSMC-320	2	6.65	6 13/16	8 7/8	10 1/2	15	3 1/2	4 15/16	37 11/16	4 11/16
FSMC-320	3	6.65	6 13/16	8 7/8	10 1/2	15	3 1/2	4 15/16	37 11/16	4 11/16
FSMC-330	2	6.65	6 13/16	8 7/8	20 1/2	15	3 1/2	4 15/16	47 11/16	4 11/16
FSMC-330	3	6.65	6 13/16	8 7/8	20 1/2	15	3 1/2	4 15/16	47 11/16	4 11/16
FSMC-340	2	6.65	6 13/16	8 7/8	30 1/2	15	3 1/2	4 15/16	57 11/16	4 11/16
FSMC-340	3	6.65	6 13/16	8 7/8	30 1/2	15	3 1/2	4 15/16	57 11/16	4 11/16
FSMC-620	2	8 5/8	7 7/8	14 1/8	10 1/2	15	4 11/16	6 5/8	43 5/16	7 1/2
FSMC-620	3	8 5/8	7 7/8	14 1/8	10 1/2	15	4 11/16	6 5/8	43 5/16	7 1/2
FSMC-630	2	8 5/8	7 7/8	14 1/8	20 1/2	15	4 11/16	6 5/8	53 5/16	7 1/2
FSMC-630	3	8 5/8	7 7/8	14 1/8	20 1/2	15	4 11/16	6 5/8	53 5/16	7 1/2
FSMC-640	2	8 5/8	7 7/8	14 1/8	30 1/2	15	4 11/16	6 5/8	63 5/16	7 1/2
FSMC-640	3	8 5/8	7 7/8	14 1/8	30 1/2	15	4 11/16	6 5/8	63 5/16	7 1/2

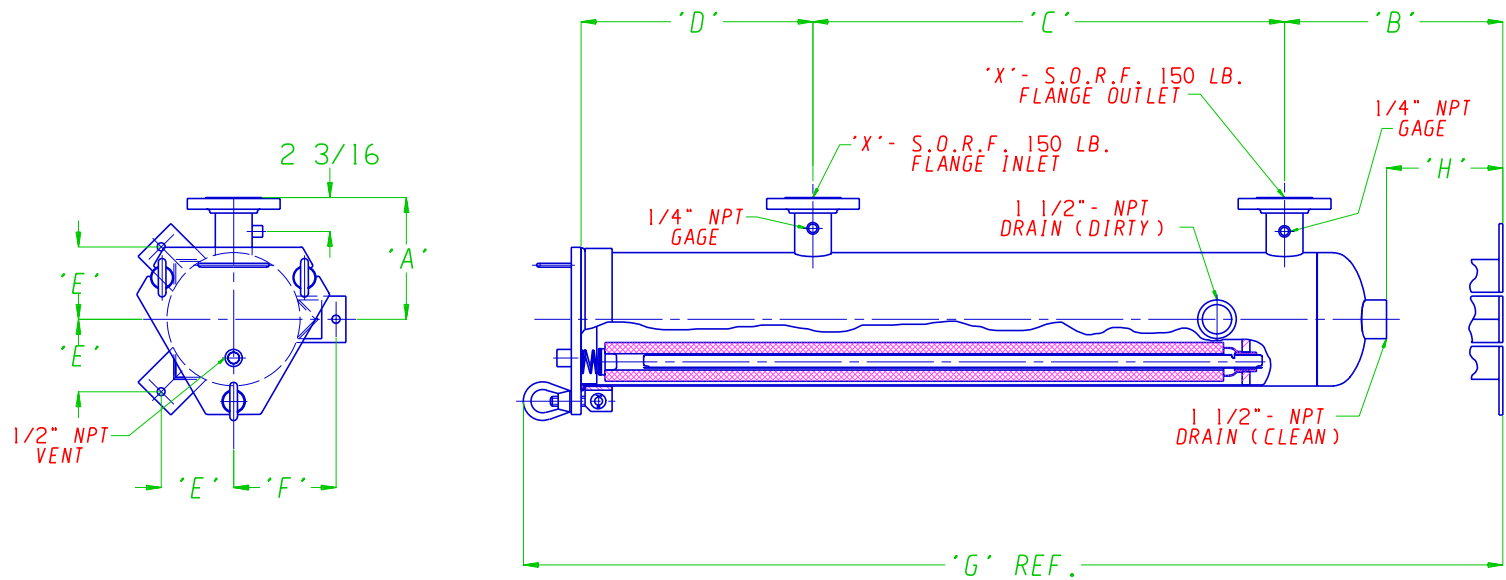

FSMC FILTER HOUSINGS STYLE 8
 3 AND 6 CARTRIDGES
 A.S.M.E. CODE