



Pall Corporation

www.pall.com

BioDiesel Production

Comprehensive Separation and Filtration Technologies

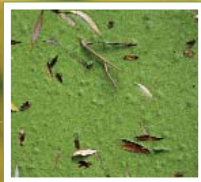

Filtration. Separation. Solution.SM

Where to Apply Pall's Separation Equipment

Pall's PhaseSep® High-efficiency Coalescer Separation Samples



Installed PhaseSep system shown with insulated glycerin boot



Feed (left), BioDiesel (middle), Coalesced Glycerin (right)



Feed (left), BioDiesel (middle), Coalesced soapy water (right)

Filter the Crude or Refined Feed Oil: **F1R**

Removal of solid particles from feed oil (pressure oil + extraction oil)

- Capable of high solids separation (50,000 ppm → 50 ppm)

Separate Glycerol or H₂O/MeOH from ME: **F2L2**

Efficient separation of glycerol from ME reduces the amount of glycerin and catalyst in ME after MeOH recovery. When a neutralization step is used, the coalescer separates H₂O and MeOH from ME.

Separate Glycerin from ME: **F3L3**

Efficient separation of glycerin from ME reduces the amount of water washing or resin for waterless purification. MeOH concentration impacts the separation of glycerin from ME. Therefore, it's important to remove MeOH as much as possible before the final separation of glycerin from ME.

Separate Wash Water from BioDiesel: **F4L4**

Water must be removed in order to meet the final BioDiesel water and glycerin specification.

Wash Water Recovery: **F5L5R5**

Allows recirculation of wash water. Coalescer recovers any BioDiesel carried over and an optimized RO regenerates wash water making it free of dissolved materials washed from the BioDiesel. Make-up water should be introduced ahead of RO, ensuring good wash water quality.

Separate ME, FFA and MONG from Crude Glycerin: **F6L6**

Results in higher purity glycerin and BioDiesel yields. Reduces loading to glycerin purification steps increasing process efficiency.

Glycerin Purification: **F7**

Removal of adsorbent and AC fines for particle-free glycerin. Adsorbents and AC can also be incorporated within the filter medium reducing the glycerin upgrading footprint.

BioDiesel Purification: **F8**

Final step in the production process involves filtering out adsorbent fines, solid precipitates, glucosides, and other solids.



Typical Process Diagram with Pall Products

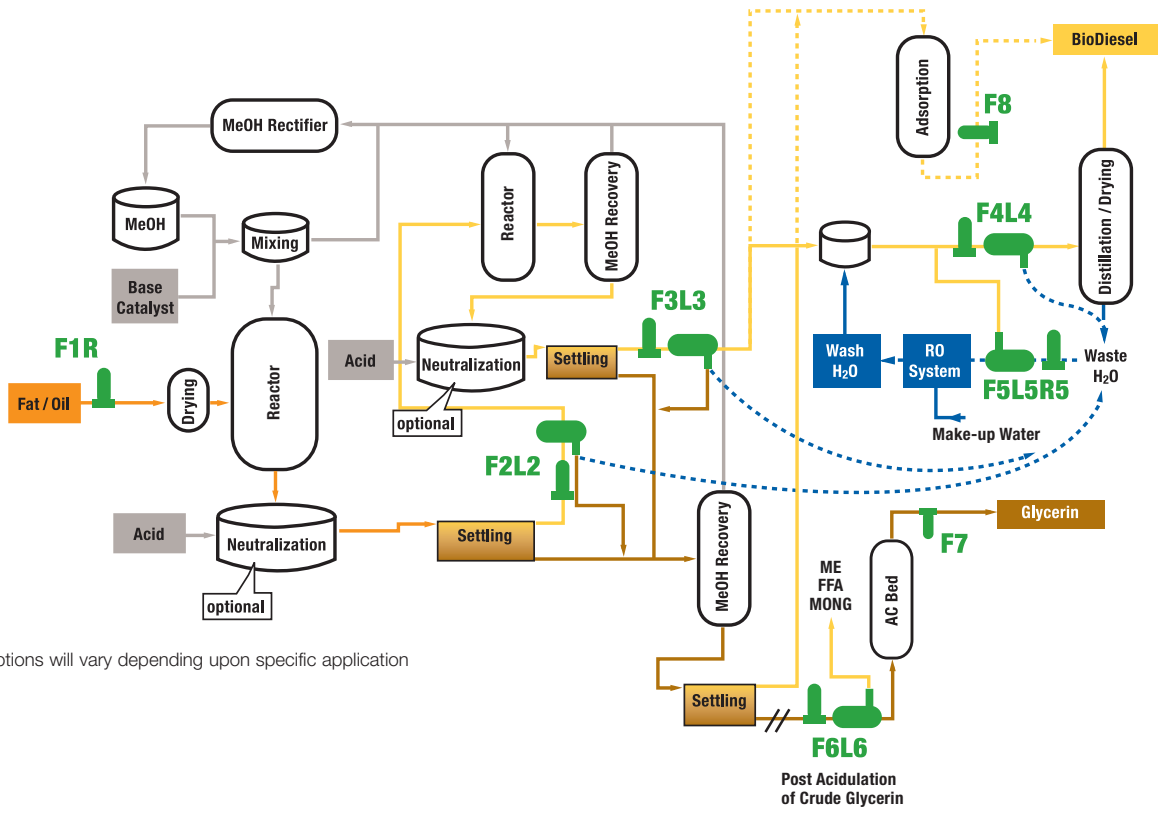

* Process options will vary depending upon specific application

Optimized Process Diagram with Pall Products

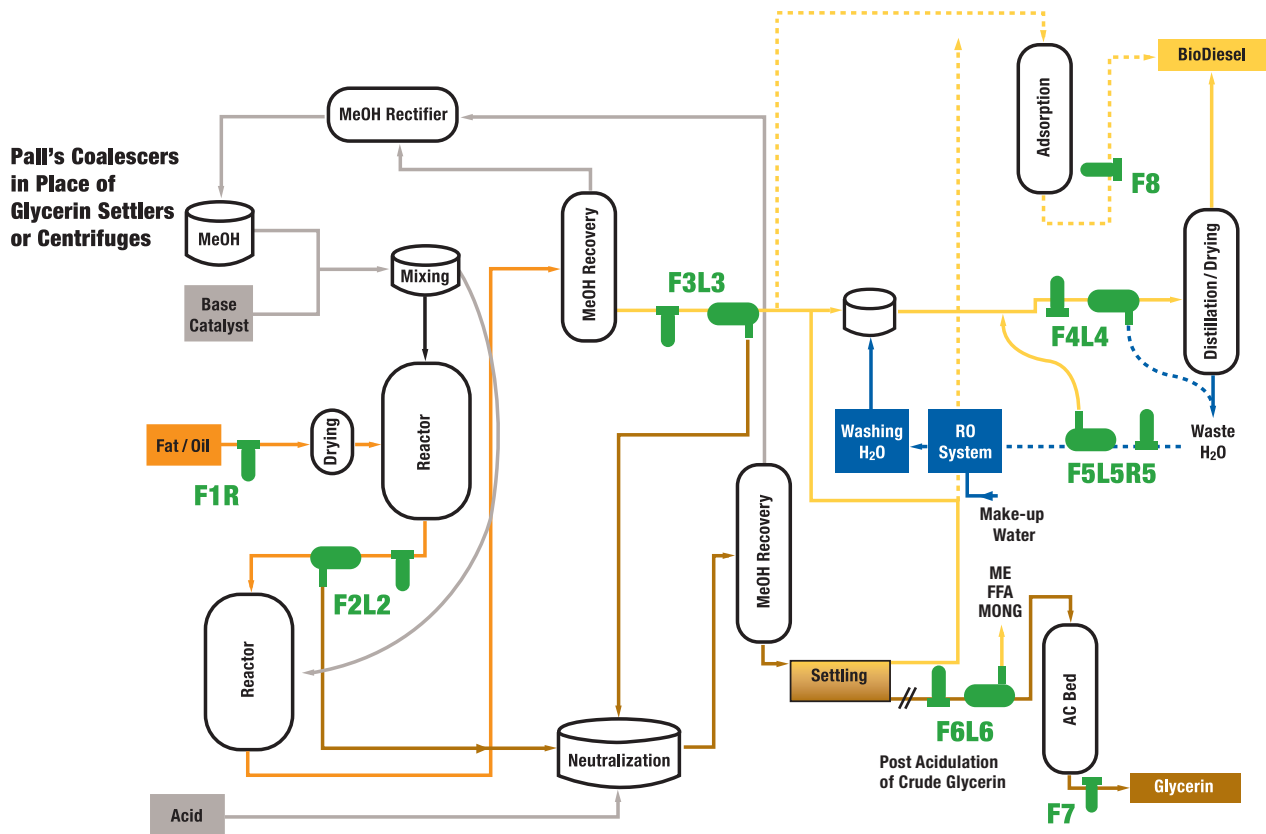

* Process options will vary depending upon specific application

What Pall Separation Equipment to Use



F1R, F7, F8: Pall's Absolute-rated Liquid Particulate Filters

Pall's absolute-rated liquid particulate filters remove solids from liquids and are available with a wide range of micron removal ratings, flow capacities, and chemical compatibilities to match process and product quality requirements.

Recommended particulate filters: Ultipleat® High Flow filters, Marksman™ filters, Profile® filters, Profile Coreless filters, Nexis® filters, Claris® filters

F2L2, F3L3, F4L4, F5L5, F6L6: Pall's Liquid/Liquid Coalescers

Pall's PhaseSep® liquid/liquid coalescers are used to separate two phases, such as glycerol or H₂O/MeOH from ME. A prefilter is used to provide protection to the coalescer and extend its life.

Recommended prefilters: Ultipleat High Flow filters, Pall Coreless filters, Marksman filters

Recommended coalescers: PhaseSep AS coalescers

Note: PhaseSep LCY coalescers are preferred when HCL is present.



F7, F8: Pall's SUPRADisc™ II Depth Filter Modules

Pall's SUPRADisc II depth filter modules can be utilized to separate fines from purified glycerin. The filter module format can include adsorptive materials allowing them to be purification devices.

Recommended products: SUPRADisc II depth filter modules

F1R, F8: Pall's ZHF Centrifugal Discharge Filter Systems

Pall's ZHF Centrifugal Discharge filter systems can be used to filter the adsorbent from the ME and is suitable when using a precoat filter for the removal of sterol glucosides, other precipitates, and wax or tar-like contaminants. Alternatively, for very high solids applications, a Pall sheet filter press can be used in place of the ZHF Centrifugal Discharge filter system.

A particulate filter (Marksman filter or SUPRADisc II module) should also be placed downstream of Pall's ZHF Centrifugal Discharge filter system for final polishing.

Recommended filtration systems: ZHF Centrifugal Discharge filter system, sheet filter press

Recommended filters for final polishing: Marksman filters, SUPRADisc II depth filter modules

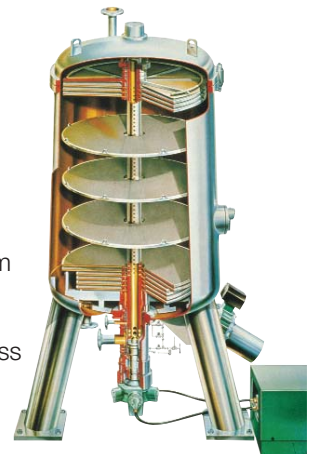

R5: Pall's DT RO Water Purification Systems

Pall's DT RO systems are installed at almost 3,000 landfill leachate and desalination sites globally. Our systems' compatibility in these difficult applications helps position Pall's technologies to operate with the chemicals typically found in BioDiesel wash water. Using Pall's coalescers in combination with the DT RO system, Pall offers a non-fouling solution that can significantly reduce the volume of wastewater generation while recovering valuable methyl ester. By recycling the wash water and adding make-up water prior to the DT RO allows Pall's system to provide RO quality wash water. This eliminates the need for a separate RO system for wash water make-up in your process.

Recommended products: Pall's DT RO system, PhaseSep liquid/liquid coalescers
Contact Pall for your complete solution and application review.

Benefits

Separation and filtration technologies play an important role in the production of BioDiesel. In order to produce a final product that meets specifications, excess water and contaminants must be efficiently removed throughout the entire production process. Pall's absolute-rated liquid particulate filters, liquid/liquid coalescers, depth filter modules, sheet filter presses, and centrifugal discharge filter systems can help producers by:

- Supplying greater separation efficiencies of glycerol/glycerin from ME
- Providing efficient separation of H₂O from BioDiesel after H₂O washing
- Reducing neutralization chemicals and wash water volumes
- Decreasing settling times and space – debottlenecking
- Enhancing distillation steps by reducing inputs – debottlenecking
- Increasing BioDiesel and glycerin product yields and purity
- Decreasing energy input
- Providing efficient separation of ME/FFA/MONG from crude glycerin
- Enabling high-purity, particle-free glycerin
- Delivering high-quality, particle-free BioDiesel final product

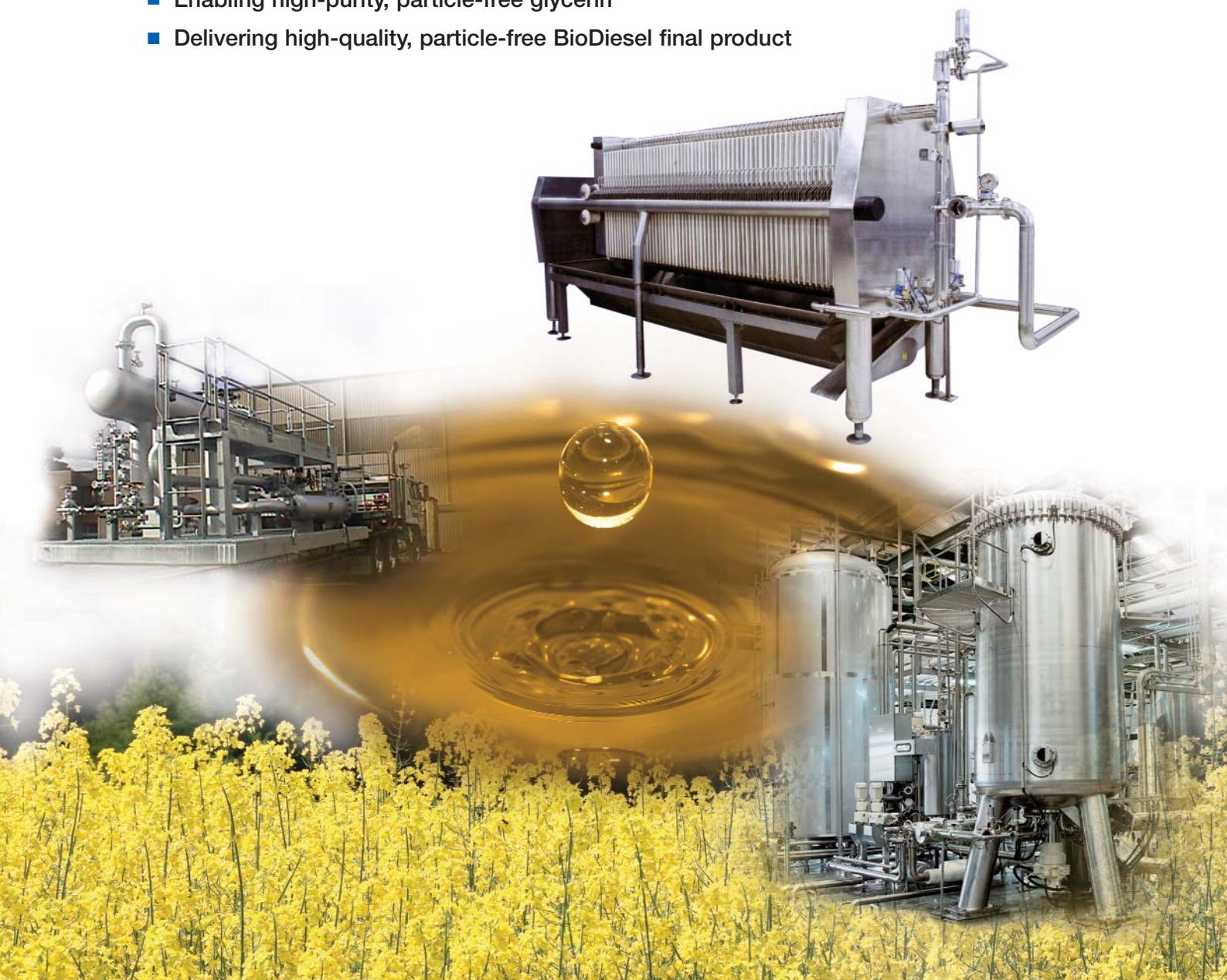

Pall Corporation – A Leader in Separation Technologies

For over 65 years, Pall Corporation has been solving complex contamination, separations, and purification problems for diverse customers around the world. With revenues of almost \$3 billion, Pall is the largest and most diverse filtration, separations, and purifications company in the world. Pall Corporation is committed to advancing technologies that create value for our customers. One area that we focus on is process efficiency increases that enable the Renewable and Alternative Energy markets. This demonstrates Pall's leadership by providing global solutions that maximize the potential for reducing the world's reliance on petroleum.

Pall offers a full range of scaleable products and services for the BioDiesel industry. For nearly two decades, we've helped producers and technology providers evaluate processes and have developed separation solutions that streamline processes, increase yields, and help improve product quality. A main application of interest in the industry is to increase the efficiency and throughput of the critical glycerin/glycerol separation step. Pall's high-efficiency coalescer systems, developed specifically for BioDiesel production, can help achieve this goal at a lower cost, with better efficiencies and reduced process times when compared to centrifuges or settlers. Other Pall cutting-edge technologies for BioDiesel processes include: high-efficiency coalescer systems to separate free water from washed BioDiesel and ME/FFA/MONG from acidulated crude glycerin, high-efficiency liquid particulate filters, centrifugal discharge filter systems and sheet filter systems, module filters with adsorptive capabilities, and pilot systems.

Pall has worked with variable feed stock applications throughout the world with many different catalyst and process conditions. This has allowed Pall to acquire a great deal of technical knowledge and experience related to the BioDiesel market. With locations strategically placed throughout the world, Pall works directly with you to develop a personalized separation solution, enabling valuable economic process improvements with services that improve your system's operations. With our primary focus being separations, you'll receive unequalled technical consultation and support from our Scientific and Laboratory Services (SLS) department, an extensive global network of scientists and engineers who are experts in their field.

We invite you to learn more about Pall's wide array of products and services for the BioDiesel industry. For more information contact your Pall representative or visit us on the web at: www.pall.com and search for BioDiesel.



Pall Corporation

Fuels and Chemicals

25 Harbor Park Drive
Port Washington, New York 11050
+1 516 484 3600 telephone
+1 888 873 7255 toll free US

Portsmouth - UK

+44 (0)23 9233 8000 telephone
+44 (0)23 9233 8811 fax
industrialeu@pall.com

Tokyo - Japan

+81 3 6901 5800 telephone
+81 3 5322 2134 fax



Better Lives.
Better Planet.SM

To see how Pall is helping enable a greener, safer and more sustainable future, visit www.pall.com/green.

Visit us on the Web at www.pall.com

Pall Corporation has offices and plants throughout the world. For Pall representatives in your area, please go to www.pall.com/contact.

Because of technological developments related to the products, systems, and/or services described herein, the data and procedures are subject to change without notice. Please consult your Pall representative or visit www.pall.com to verify that this information remains valid. Products in this document may be covered by one or more patent numbers. For a complete list of Pall's patents, please visit www.pall.com/main/about-pall/patents.page

© Copyright 2008, 2013 Pall Corporation. Pall, , Claris, Marksman, Nexis, PhaseSep, Profile, SUPRAdisc, and Ultipleat are trademarks of Pall Corporation.

® Indicates a trademark registered in the USA. Filtration. Separation. Solution.SM and Better Lives. Better Planet.SM are service marks of Pall Corporation.